



ISO 9001:2015 CERTIFIED

BIDDING DOCUMENT

for the
Procurement of

IMPROVEMENT OF KRA ICT CONNECTIVITY INFRASTRUCTURE AT KILINDINI PORT

IFB No: **KE-KRA-102514-GO-RFB**
Project: **EASTERN AFRICA REGIONAL TRANSPORT,
TRADE AND DEVELOPMENT FACILITATION
PROJECT (EARTTDFP)**
Purchaser: **KENYA REVENUE AUTHORITY (KRA), KENYA**
Revised Issue on : **28TH MAY, 2019**

CONTENTS

Invitation for Bids (IFB)	5
Section I. Instructions to Bidders (ITB)	9
Table of Clauses.....	10
Section II. Bid Data Sheet (BDS)	45
Section III. Eligible Countries for the Provision of Goods, Works, and Services in Bank-Financed Procurement	53
Eligible Countries for the Provision of Goods, Works, and Services in Bank-Financed Procurement	54
Section IV. General Conditions of Contract	55
Table of Clauses.....	56
Section V. Special Conditions of Contract (SCC)	129
Table of Clauses.....	130
Section VI. Technical Requirements (including Implementation Schedule)	145
Table of Contents: Technical Requirements	211
Section VII. Sample Forms	234
Notes to Bidders on working with the Sample Forms	234
Table of Sample Forms.....	237

INVITATION FOR BIDS (IFB)

Revised Issue on: **28TH MAY, 2019**

Country: **KENYA**

Name of Project: **EASTERN AFRICA REGIONAL TRANSPORT, TRADE AND DEVELOPMENT FACILITATION PROJECT (EARTTDFP)**

Brief Description: **THE PROCUREMENT CONSIST OF;**

LOT 1: DESIGN, SUPPLY, INSTALLATION, CONFIGURATION AND COMMISSIONING OF A FIBER OPTIC BASED METROPOLITAN AREA NETWORK (MAN) AND LOCAL AREA NETWORKS (LANs) IN KILINDINI PORT.

LOT 2: DESIGN, SUPPLY, INSTALLATION, CONFIGURATION AND COMMISSIONING OF AN ENTERPRISE NETWORK MANAGEMENT AND WAN OPTIMISATION SOLUTION

A BIDDER CAN APPLY FOR ANY ONE OR BOTH LOTS.

Loan /Credit Number: **5638-KE**

IFB Title: **IMPROVEMENT OF KRA ICT CONNECTIVITY INFRASTRUCTURE AT KILINDINI PORT**

IFB Number: **KE-KRA-102514-GO-RFB**

1. This Invitation for Bids (IFB) follows the General Procurement Notice (GPN) for this project that appeared in UNDB online on **21st November 2017**.
2. The Government of Kenya (GOK) has received credit from the International Development Association toward the cost of the Eastern Africa Regional Trade and Transport Facilitation Project (EARTTDFP), and intends to apply part of the proceeds of this credit to payments under the agreement(s) resulting from this IFB: **KE-KRA-102514-GO-RFB**.

3. The Kenya Revenue Authority (KRA) serves as the implementing agency for the project and now invites sealed bids from eligible Bidders for improvement of KRA ICT connectivity infrastructure at Kilindini Port which will encompass mainly:
 1. Laying of Backbone Fibre Cable
 2. New LAN Installations
 3. Addition of LAN Data Points on Existing LAN
 4. Implementation of the fibre optic cable layout shall be based on Star Bus Architecture
 5. Deploying of the optic fibre cables
 6. Civil Works which will be limited to TWO sites
 7. Design, supply, installation, configuration and commissioning of an enterprise network management and WAN optimisation solution
4. Bidding will be conducted through the International Competitive Bidding procedures as specified in the World Bank's "Procurement Regulations for IPF Borrowers" dated July, 2016 ("Procurement Guidelines"), and is open to all eligible bidders as defined in the Procurement Guidelines.
5. A pre-bid briefing for both Lot 1 and Lot 2 will be conducted on **11th June, 2019** and **13th June, 2019 at 08:30 am**. A **mandatory** site survey for **Lot 1** shall be conducted in two groups on **Tuesday, 11th June, 2019** and **Thursday, 13th June, 2019** at **Kilindini Port in Mombasa, Kenya**. Each site survey is expected to take two days. Bidders will converge at **Forodha House, Mombasa** at **8.30 am EAT** on **11th June, 2019** and **8.30 am EAT** on **13th June, 2019** respectively before proceeding to the site. Bidders who plan to attend the survey/pre-bid briefing should send an email to eprocurement@kra.go.ke indicating their preferred slot for planning purposes.
6. A complete set of bidding documents in **English language** shall be downloaded from www.kra.go.ke. Bidders who download the bidding documents shall register by sending an email to eprocurement@kra.go.ke indicating their contact details and the tender reference number. Registration and, as the case may be, download of the bidding documents, is free of charge. Prior registration is required for submitting clarification questions on the bidding documents and receiving automatic notice of answers and of addenda to the bidding documents. The downloadable version of the bidding documents, and any addenda to it, will be the binding one.
7. **Submission of bids shall strictly be done through the KRA E-Procurement Portal.** Prospective bidders should register on KRA's website; www.kra.go.ke by clicking on "New Supplier Registration" found under the E - Procurement Tab. For assistance on the supplier portal or registration, visit any KRA Procurement Office countrywide or email: srmsupport@kra.go.ke. Completed bids are to be saved as PDF files named with

- the relevant tender description and submitted in the KRA E-procurement Web Portal so as to be received on or before **28th June, 2019 at 1100 hrs.**
8. Bids will need to be secured by a Bid Security valid for 180 days from the date of tender closing. The amount of bid security required is **Kenya Shillings One Million (KES 1,000,000.00)** or **United States Dollars Ten thousand (USD 10,000)** for Lot 1 and **Kenya Shillings Five Hundred Thousand (KES 500,000)** or **United States Dollars Five Thousand (USD 5,000)** for Lot 2. The physical original bid security is to be submitted in the tender box on the Ground Floor of Times Tower Building. Late bid security will be rejected and thus invalidating the respective bid. Bids will be opened electronically promptly after closing time and Bidders or their representatives are welcome to witness the opening on **Ground Floor (iSupport Office), Times Tower Building 1100hrs EAT time on Friday, 28th June, 2019.**

 8. The attention of prospective Bidders is drawn to (i) the fact that they will be required to certify in their bids that all software is either covered by a valid license or was produced by the Bidder and (ii) that violations are considered fraud, which can result in ineligibility to be awarded World Bank-financed contracts.

 9. Interested eligible bidders may obtain further information from the **Kenya Revenue Authority** between **9.00 am and 5.00 pm East African Time** everyday excluding weekends and public holidays at the address given below.

COMMISSIONER GENERAL
KENYA REVENUE AUTHORITY (KRA)
P.O. BOX 48240 – 00100, NAIROBI, KENYA
HAILE SELASSIE AVENUE, TIMES TOWER BUILDING

Telephone: **+254 709012374**

Facsimile number: **+254 20 215 809**

Email: eprocurement@kra.go.ke

Web page: www.kra.go.ke

SUBMISSION CHECKLIST

	Disclaimer: This list is just a generic reminder. Otherwise, the bidder is responsible to read all the requirements of the bidding document and submit all the required documentation in his bid, as required.	
A.	MANDATORY DOCUMENTS	CHECK IF ATTACHED
i.	Copy of Business Registration/Incorporation Certificate	
ii.	Valid Tax Compliance Certificate	
iii.	Power of Attorney	
iv.	Manufacturer's Authorization for all equipment & software	
v.	Proof of OEMs commitment in supporting the project implementation	
vi.	(a) Local bidders will be required to have a Telecommunications Contractor License issued by the Communications Authority of Kenya (CAK) (b) International bidders will be required to have a Telecommunications Contractor License (or equivalent) issued by relevant authorities in their country of origin.	Applicable to Lot 1 only
vii.	(a) Local bidders will be required to have NCA 5 Contractor (or above) Certificate (Building and Works OR Roads and other Civil works) issued by the National Construction Authority (NCA) (b) International bidders will be required to have Contractor License (Building and Works OR Roads and other Civil works) issued by relevant authorities in their country of origin.	Applicable to Lot 1 only
viii.	Valid Site Survey Certificate (to be issued at the site)	Applicable to Lot 1 only
B.	FINANCIAL	
i.	Bid Security - KES. 1,000,000.00 or USD10,000 for Lot 1 and KES. 500,000.00 or USD 5,000 for Lot 2.	
ii.	Bid Submission Form	
iii.	Grand Summary Cost Table	
C.	DEMO	
	Attach a soft copy of the demo for proposed Enterprise Network Management and WAN Optimization Solution	

SECTION I. INSTRUCTIONS TO BIDDERS (ITB)
(Single-Stage Bidding)

Table of Clauses

A. General	12
1. Scope of Bid and Bidding Process.....	12
2. Source of Funds	12
3. Fraud and Corruption.....	13
4. Eligible Bidders	15
5. Eligible Goods and Services	16
6. Qualifications of the Bidder.....	17
7. Cost of Bidding.....	20
8. Site Visit.....	20
B. The Bidding Documents	20
9. Content of Bidding Documents	20
10. Clarification of Bidding Documents and Pre-bid Meeting	21
11. Amendment of Bidding Documents	21
C. Preparation of Bids	22
12. Language of Bid.....	22
13. Documents Comprising the Bid.....	22
14. Bid Prices	24
15. Bid Currencies	27
16. Documents Establishing the Conformity of the Information System to the Bidding Documents	27
17. Securing the Bid.....	28
18. Period of Validity of Bids	30
19. Format and Signing of Bid.....	31
D. Submission of Bids	31
20. Sealing and Marking of Bids	31
21. Deadline for Submission of Bids	32
22. Late Bids	32
23. Withdrawal, Substitution, and Modification of Bids.....	32
E. Bid Opening and Evaluation	33
24. Opening of Bids by Purchaser	33
25. Clarification of Bids.....	34
26. Preliminary Examination of Bids.....	35
27. Conversion to Single Currency.....	36
28. Evaluation and Comparison of Bids	36
29. Domestic Preference	41
30. Contacting the Purchaser	41
F. Postqualification and Award of Contract	42
31. Postqualification	42
32. Award Criteria	42
33. Purchaser's Right to Vary Quantities at Time of Award.....	42

34. Purchaser’s Right to Accept Any Bid and to Reject Any or All Bids	43
35. Notification of Award	43
36. Signing of Contract	44
37. Performance Security	44
38. Adjudicator	44

Instructions to Bidders

A. GENERAL

- 1. Scope of Bid and Bidding Process**
 - 1.1 The Purchaser named in the BDS and the SCC for GCC Clause 1.1 (b) (i), or its duly authorized Purchasing Agent if so **specified in the BDS** (interchangeably referred to as “the Purchaser” in these Bidding Documents), invites bids for the supply and installation of the Information System (IS), as briefly **described in the BDS** and specified in greater detail in these Bidding Documents.
 - 1.2 The title and identification number of the Invitation for Bids (IFB) and resulting Contract(s) are **provided in the BDS**.
 - 1.3 Throughout the Bidding Documents, the term "in writing" means communicated in written form (e.g. by mail, e-mail, fax, telex) with proof of receipt, and the term "days" means calendar days unless a different meaning is evident from the context.
 - 1.4 If the BDS so provides, alternative procedures forming part or all of what is commonly known as e-Tendering are available to the extent **specified in, or referred to by, the BDS**.
- 2. Source of Funds**
 - 2.1 The **Borrower named in the BDS** has applied for or received a loan or credit (as identified in the BDS, and called a “loan” in these Bidding Documents) from the International Bank for Reconstruction and Development or the International Development Association (called “the Bank” in these Bidding Documents) equivalent to the amount indicated in the BDS toward the cost of the Project specified in the BDS. The Borrower intends to apply a portion of the proceeds of this loan to eligible payments under the Contract for which these Bidding Documents are issued.
 - 2.2 Payment by the Bank will be made only at the request of the Borrower, or the Borrower’s executing agency, and upon approval by the Bank in accordance with the terms and conditions of the Loan Agreement, and will be subject in all respects to the terms and conditions of that agreement. The Loan Agreement prohibits a withdrawal from the loan account for the purpose of any payment to persons or entities, or for any import of goods, if such payment or import, to the knowledge of the Bank, is prohibited by a decision of the United Nations Security Council taken under Chapter VII of the Charter of the United Nations. No

party other than the Borrower shall derive any rights from the Loan Agreement or have any claim to the loan proceeds.

3. Fraud and Corruption

3.1 It is the Bank's policy to require that Borrowers (including beneficiaries of Bank loans), as well as bidders, suppliers, and contractors and their subcontractors under Bank-financed contracts, observe the highest standard of ethics during the procurement and execution of such contracts.¹ In pursuance of this policy, the Bank:

- (a) defines, for the purposes of this provision, the terms set forth below as follows:
 - (i) "corrupt practice"² is the offering, giving, receiving or soliciting, directly or indirectly, of anything of value to influence improperly the actions of another party;
 - (ii) "fraudulent practice"³ is any act or omission, including a misrepresentation, that knowingly or recklessly misleads, or attempts to mislead, a party to obtain a financial or other benefit or to avoid an obligation;
 - (iii) "collusive practice"⁴ is an arrangement between two or more parties designed to achieve an improper purpose, including to influence improperly the actions of another party;
 - (iv) "coercive practice"⁵ is impairing or harming, or threatening to impair or harm, directly or indirectly, any party or the property of the party to influence improperly the actions of a party;
 - (v) "obstructive practice" is
 - (aa) deliberately destroying, falsifying, altering or concealing of evidence material to the
-

investigation or making false statements to investigators in order to materially impede a Bank investigation into allegations of a corrupt, fraudulent, coercive or collusive practice; and/or threatening, harassing or intimidating any party to prevent it from disclosing its knowledge of matters relevant to the investigation or from pursuing the investigation; or

- (bb) acts intended to materially impede the exercise of the Bank's inspection and audit rights provided for under sub-clause 3.1 (e) below.
 - (b) will reject a proposal for award if it determines that the bidder recommended for award has, directly or through an agent, engaged in corrupt, fraudulent, collusive, coercive or obstructive practices in competing for the contract in question;
 - (c) will cancel the portion of the loan allocated to a contract if it determines at any time that representatives of the Borrower or of a beneficiary of the loan engaged in corrupt, fraudulent, collusive, or coercive practices during the procurement or the execution of that contract, without the Borrower having taken timely and appropriate action satisfactory to the Bank to address such practices when they occur;
 - (d) will sanction a firm or individual, including declaring ineligible, either indefinitely or for a stated period of time, to be awarded a Bank-financed contract if it at any time determines that the firm has, directly or through an agent, engaged in corrupt, fraudulent, collusive, coercive or obstructive practices in competing for, or in executing, a Bank-financed contract; and
 - (e) will have the right to require that a provision be included in bidding documents and in contracts financed by a Bank loan, requiring bidders, suppliers, and contractors and their sub-contractors to permit the Bank to inspect their accounts and records and other documents relating to the bid submission and contract performance and to have them audited by auditors appointed by the Bank.
- 3.2 Furthermore, Bidders shall be aware of the provision stated in Clause 9.8 and Clause 41.2 of the General Conditions of Contract.

3.3 Any communications between the Bidder and the Purchaser related to matters of alleged fraud or corruption must be made in writing.

3.4 By signing the Bid Submission Form, the Bidder represents that it either is the owner of the Intellectual Property Rights in the hardware, software or materials offered, or that it has proper authorization and/or license to offer them from the owner of such rights. For the purpose of this Clause, Intellectual Property Rights shall be as defined in GCC Clause 1.1 (c) (xvii). Willful misrepresentation of these facts shall be considered a fraudulent practice subject to the provisions of Clauses 3.1 through 3.4 above, without prejudice of other remedies that the Purchaser may take.

4. Eligible Bidders

4.1 A Bidder, and all parties constituting the Bidder, may have the nationality of any country, subject to the restrictions specified in Section III, Eligible Countries. A Bidder shall be deemed to have the nationality of a country if the Bidder is a citizen or is constituted, incorporated, or registered and operates in conformity with the provisions of the laws of that country.

4.2 If a prequalification process has been undertaken for the Contract(s) for which these Bidding Documents have been issued, only those Bidders may participate that had been prequalified and continue to meet the eligibility criteria of this Clause. A prequalified Joint Venture may not change partners or its structure when submitting a bid.

4.3 A firm may be excluded from bidding if:

(a) it was engaged by the Purchaser to provide consulting services for the preparation of the design, specifications, or other documents to be used for the procurement of the Information System described in these Bidding Documents; or

(b) it is a government-owned enterprise in the Borrower's country, unless it can establish that it (i) is legally and financially autonomous and (ii) operates under commercial law. No dependent agency of the Borrower or Sub-Borrower shall be permitted to bid.

4.4 A firm that has been determined to be ineligible by the Bank in relation to the Bank Guidelines On Preventing and Combating Fraud and Corruption in Projects Financed by IBRD Loans and IDA Credits and Grants shall be not be eligible to be awarded a contract.

- 4.5 A firm or individual is or will be disqualified from participation in this bidding if, at any time from advertisement of the bidding until and including contract award, the firm or individual is under:
- (a) a suspension by the Purchaser agreed by the Bank as a result of execution of a Bid-Securing Declaration pursuant to ITB Clause 17.6 in another Bank-financed procurement, or under a suspension by the Purchaser for other reasons that have been agreed by the Bank; or
 - (b) a declaration of ineligibility by the Bank in accordance with ITB Clause 3.1 (d). The list of individuals and firms debarred from participating in World Bank projects is available at <http://www.worldbank.org/debarr/>, or
 - (c) a sanction imposed by the United Nations Security Council, as mentioned in ITB Clause 2.2.
- 4.6 A firm or other entity that is ineligible according to any of the above provisions of this Clause, may also not participate as a Joint Venture partner, or as Subcontractor for or supplier of goods, works or services. If a bid becomes materially incomplete after removing ineligible entities, the bid may be disqualified.
- 4.7 Bidders shall provide such evidence of their continued eligibility satisfactory to the Purchaser, as the Purchaser shall reasonably request.

5. Eligible Goods and Services

- 5.1 For the purposes of these Bidding Documents, the Information System means all:
- (a) the required information technologies, including all information processing and communications-related hardware, software, supplies, and consumable items that the Supplier is required to supply and install under the Contract, plus all associated documentation, and all other materials and goods to be supplied, installed, integrated, and made operational (collectively called “the Goods” in some clauses of the ITB); and
 - (b) the related software development, transportation, insurance, installation, customization, integration, commissioning, training, technical support, maintenance, repair, and other services necessary for proper operation of the Information System to be provided by the selected Bidder and as specified in the Contract.
- 5.2 Funds from Bank loans are disbursed only for expenditures for an Information System made up of goods and services provided by

nationals of, and produced in or supplied from, eligible source countries as defined in Section III, Eligible Countries. An Information System is deemed to be produced in a certain country when, in the territory of that country, through software development, manufacturing, or substantial and major assembly or integration of components, a commercially recognized product results that is substantially different in basic characteristics or in purpose or utility from its components.

5.3 For purposes of this clause, the nationality of the Bidder is distinct from the country in which the Information System and its goods components are produced or from which the related services are supplied.

6. Qualifications of the Bidder

6.1 By submission of documentary evidence in its bid, the Bidder must establish to the Purchaser's satisfaction:

(a) that it has the financial, technical, and production capability necessary to perform the Contract, meets the qualification criteria **specified in the BDS**, and has a successful performance history. If a prequalification process has been undertaken for the Contract(s) for which these Bidding Documents have been issued, the Bidder shall, as part of its bid, update any information submitted with its application for prequalification;

(For the purposes of establishing a Bidder's qualifications, and unless stated to the contrary in the BDS, the experience and / or resources of any Subcontractor will not contribute to the Bidder's qualifications; only those of a Joint Venture partner will be considered.)

(b) that, in the case of a Bidder offering to supply key goods components of the Information System, as **identified in the BDS**, that the Bidder does not itself produce, the Bidder is duly authorized by the producer to supply those components in the Purchaser's country under the Contract(s) that may result from this bidding; (This will be accomplished by including Manufacturer's Authorizations in the bid, based on the sample found in Section VII.)

(c) that, if a Bidder proposes Subcontractors for key services if and as **identified in the BDS**, these Subcontractors have agreed in writing to serve for the Bidder under the Contract(s) that may result from this bidding; and

(d) that, in the case of a Bidder not doing business within the Purchaser's country, the Bidder is or will be (if awarded the

Contract) represented by an Agent in that country who is equipped and able to carry out the Bidder's maintenance, technical support, training, and repair obligations prescribed in the General and Special Conditions of Contract, and/or Technical Requirements.

- 6.2 Bids submitted by a Joint Venture of two or more firms as partners shall also comply with the following requirements:
- (a) the bid shall be signed so as to be legally binding on all partners;
 - (b) one of the partners shall be nominated as being in charge, and this nomination shall be evidenced by submitting a power of attorney signed by legally authorized signatories of all the partners;
 - (c) the partner in charge shall be authorized to incur liabilities and receive instructions for and on behalf of any and all partners of the Joint Venture, and the entire execution of the Contract, including payment, shall be done exclusively with the partner in charge;
 - (d) the partner or combination of partners that is responsible for a specific component of the Information System must meet the relevant minimum qualification criteria for that component;
 - (e) a firm may submit bids either as a single Bidder on its own, or as partner in one, and only one, Joint Venture. If, as a result of the bid opening pursuant to ITB Clause 24, this requirement is not met, all bids involving the firm as a single Bidder or Joint Venture partner will be disqualified;
 - (f) all partners of the Joint Venture shall be liable jointly and severally for the execution of the Contract in accordance with the Contract terms, and a statement to this effect shall be included in the authorization mentioned under ITB Clause 6.2 (b) above, in the bid as well as in the Contract (in case of a successful bid).
- 6.3 If a Bidder intends to subcontract major items of supply or services, it shall include in the bid details of the name and nationality of the proposed Subcontractor for each of those items and shall be responsible for ensuring that any Subcontractor proposed complies with the requirements of ITB Clause 4, and that any Goods or Services components of the Information System to be provided by the Subcontractor comply with the

requirements of ITB Clause 5 and the related evidence required by ITB Clause 13.1 (e) (iii) is submitted. Bidders are free to list more than one Subcontractor against each item. Quoted rates and prices will be deemed to apply, whichever Subcontractor is appointed, and no adjustment of the rates or prices will be permitted. The Purchaser reserves the right to delete any proposed Subcontractor from the list. This shall be done prior to Contract signature, by deleting such unacceptable Subcontractors from Appendix 3 to the Contract Agreement, which shall list the approved Subcontractors for each item prior to Contract signature. Subsequent additions and deletions from the list of approved Subcontractors shall be performed in accordance with GCC Clause 20 (as revised in the SCC, if applicable) and Appendix 3 to the Contract Agreement.

For the purposes of these Bidding Documents, a Subcontractor is any vendor or service provider with whom the Bidder contracts for the supply or execution of any part of the Information System to be provided by the Bidder under the Contract (such as the supply of major hardware, software, or other components of the required Information Technologies specified, or the performance of related Services, e.g., software development, transportation, installation, customization, integration, commissioning, training, technical support, maintenance, repair, etc.).

- 6.4 A firm which is a Bidder, whether as a single Bidder or as a partner in a Joint Venture, cannot be a Subcontractor in other bids, except for the supply of commercially available hardware or software by the firm, as well as purely incidental services such as installation/configuration, routine training, and ongoing maintenance/support. If the BDS for ITB Clause 6.1 (a) allows the qualification of Subcontractors nominated for certain components to be taken into account in assessing the Bidder's overall qualifications, any Subcontractor so nominated by any Bidder is automatically disqualified from being a Bidder itself or a partner in a Joint Venture. The same will normally apply to firms that have provided Subcontractor agreements for certain services pursuant to ITB Clause 6.1 (c). Non-compliance may result in the rejection of all bids in which the affected firm participates as Bidder or as partner in a Joint Venture. As long as in compliance with these provisions, or as long as unaffected by them due to not participating as Bidder or as partner in a Joint Venture, a firm may be proposed as a Subcontractor in any number of bids. If the BDS for ITB 28.1 permits the submission of bids for Subsystems, lots, or slices, then the provisions of this

Clause 6.4 apply only to bids for the same Subsystem(s), lot(s), or slice(s);

- 7. Cost of Bidding**
- 7.1 The Bidder shall bear all costs associated with the preparation and submission of its bid, and the Purchaser will in no case be responsible or liable for those costs.
- 8. Site Visit**
- 8.1 The Bidder may wish to visit and examine the site or sites of the Information System and obtain for itself, at its own responsibility and risk, all information that may be necessary for preparing the bid and entering into the Contract. The costs of visiting the site or sites shall be at the Bidder's own expense.
- 8.2 The Purchaser will arrange for the Bidder and any of its personnel or agents to gain access to the relevant site or sites, provided that the Bidder gives the Purchaser adequate notice of a proposed visit of at least fourteen (14) days. Alternatively, the Purchaser may organize a site visit or visits concurrently with the pre-bid meeting, as specified in the BDS for ITB Clause 10.2. Failure of a Bidder to make a site visit will not be a cause for its disqualification.
- 8.3 No site visits shall be arranged or scheduled after the deadline for the submission of the Bids and prior to the award of Contract.

B. THE BIDDING DOCUMENTS

- 9. Content of Bidding Documents**
- 9.1 The contents of the Bidding Documents are listed below and should be read in conjunction with any addenda issued in accordance with ITB Clause 11:
- Section I Instructions to Bidders (ITB)
 - Section II Bid Data Sheet (BDS)
 - Section III Eligible Countries for the Provision of Goods, Works, and Services in Bank-Financed Procurement
 - Section IV General Conditions of Contract (GCC)
 - Section V Special Conditions of Contract (SCC)
 - Section VI Technical Requirements (including Implementation Schedule)
 - Section VII Sample Forms
- 9.2 Bidders are expected to examine all instructions, forms, terms, specifications, and other information in the Bidding Documents.

Failure to furnish all information required by the Bidding Documents or to submit a bid not substantially responsive to the Bidding Documents in every respect will be at the Bidder's risk and may result in the rejection of its bid.

- 9.3 The Invitation for Bids is not formally part of the Bidding Documents and is included for reference only. In case of inconsistencies, the actual Bidding Documents shall prevail.

10. Clarification of Bidding Documents and Pre-bid Meeting

- 10.1 A prospective Bidder requiring any clarification of the Bidding Documents may notify the Purchaser in writing at the Purchaser's address and by one of the means **indicated in the BDS**. Similarly, if a Bidder feels that any important provision in the documents will be unacceptable; such an issue should be raised as soon as possible. The Purchaser will respond in writing to any request for clarification or modification of the Bidding Documents that it receives no later than twenty-one (21) days prior to the deadline for submission of bids prescribed by the Purchaser. Copies of the Purchaser's response (including an explanation of the query but not identifying its source) will be sent to all prospective Bidders that received the Bidding Documents from the Purchaser.

- 10.2 When **specified in the BDS**, the Purchaser will organize and Bidders are welcome to attend a pre-bid meeting at the time and place **indicated in the BDS**. The purpose of the meeting will be to clarify issues and answer questions on any matter that may be raised at this stage, with particular attention to issues related to the Technical Requirements. Bidders are requested to submit any questions in writing to reach the Purchaser not later than one week before the meeting. Questions and answers will be transmitted in accordance with ITB Clause 10.1. Minutes of the meeting, including the questions raised and responses given, together with any responses prepared after the meeting, will be transmitted without delay to all those that received the Bidding Documents from the Purchaser. Any modification to the Bidding Documents listed in ITB Clause 9.1, which may become necessary as a result of the pre-bid meeting, shall be made by the Purchaser exclusively by issuing an Addendum pursuant to ITB Clause 11 and not through the minutes of the pre-bid meeting.

11. Amendment of Bidding Documents

- 11.1 At any time prior to the deadline for submission of bids, the Purchaser may, for any reason, whether at its own initiative or in response to a clarification requested by a prospective Bidder, amend the Bidding Documents. Later amendments on the same subject modify or replace earlier ones.

- 11.2 Amendments will be provided in the form of Addenda to the Bidding Documents, which will be sent in writing to all

prospective Bidders that received the Bidding Documents from the Purchaser. Addenda will be binding on Bidders. Bidders are required to immediately acknowledge receipt of any such Addenda. It will be assumed that the amendments contained in such Addenda will have been taken into account by the Bidder in its bid.

- 11.3 In order to afford prospective Bidders reasonable time in which to take the amendment into account in preparing their bids, the Purchaser may, at its discretion, extend the deadline for the submission of bids, in which case, the Purchaser will notify all Bidders in writing of the extended deadline.

C. PREPARATION OF BIDS

- 12. Language of Bid** 12.1 The bid prepared by the Bidder and all correspondence and documents related to the bid exchanged by the Bidder and the Purchaser shall be written in the **language specified in the BDS**, or, if the BDS so provides, in either one of two languages specified there. Any printed literature furnished by the Bidder as part of its bid may be in a language not specified in the BDS, as long as such literature is accompanied by a translation of its pertinent passages into the language of the bid, in which case, for purposes of interpretation of the bid, the translation shall govern.

- 13. Documents Comprising the Bid** 13.1 The bid submitted by the Bidder shall comprise:
- (a) Bid Submission Form completed and signed by a person or persons duly authorized to bind the Bidder to the Contract;
 - (b) all Price Schedules duly completed in accordance with ITB Clauses 14, 15, and 18 and signed by a person or persons duly authorized to bind the Bidder to the Contract;
 - (c) if required, Bid-securing Declaration or Bid Security furnished in accordance with ITB Clause 17;
 - (d) written confirmation authorizing the signatory of the bid to commit the Bidder, in accordance with ITB Clause 19.2;
 - (e) Attachments:
 - (i) Attachment 1: Bidder's Eligibility

In the absence of prequalification, documents establishing to the Purchaser's satisfaction the Bidder's eligibility to bid, including but not limited to documentary evidence that the Bidder is legally

incorporated in a territory of an eligible source country as defined under ITB Clause 4;

(ii) Attachment 2: Bidder's Qualifications

Documentary evidence establishing to the Purchaser's satisfaction, and in accordance with ITB Clause 6, that the Bidder is qualified to perform the Contract if its bid is accepted. In the case where prequalification of Bidders has been undertaken, and pursuant to ITB Clause 6.1 (a), the Bidder must provide evidence on any changes in the information submitted as the basis for prequalification or, if there has been no change at all in said information, a statement to this effect;

Any Manufacturer's Authorizations and Subcontractor agreements specified as required in the BDS for ITB Clauses 6.1 (b) and 6.1 (c);

(iii) Attachment 3: Eligibility of Goods and Services

Documents establishing, to the Purchaser's satisfaction, that the Goods and Services components of the Information System to be supplied, installed, and/or performed by the Bidder are eligible Goods and Services as defined under ITB Clause 5. If awarded the Contract, the Bidder shall submit for such components of the Information System evidence of eligibility, which shall be confirmed by a certificate of origin issued at the time of shipment;

(iv) Attachment 4: Conformity of the Information System to the Bidding Documents

Documentary evidence establishing to the Purchaser's satisfaction, and in accordance with ITB Clause 16, that the Goods and Services components of the Information System to be supplied, installed, and/or performed by the Bidder conform to the Bidding Documents;

(v) Attachment 5: Proposed Subcontractors

A list of all major items of Goods or Services that the Bidder proposes to purchase or subcontract from others, and the name and nationality of the proposed Subcontractor, including vendors, for each of those items;

(vi) Attachment 6: Intellectual Property

A list of:

- (1) all Software included in the Bidder's bid, assigning each item to one of the software categories defined in GCC Clause 1.1 (c):
 - (A) System, General Purpose, and Application Software; and
 - (B) Standard and Custom Software.
- (2) all Custom Materials, as defined in GCC Clause 1.1 (c), included in the Bidder's bid.

All Materials not identified as Custom Materials shall be deemed Standard Materials, as defined in GCC Clause 1.1 (c).

Re-assignments among the Software and Materials categories, if necessary, will be made during the implementation of the Contract according to GCC Clause 39 (Changes to the System).

14. Bid Prices

- 14.1 All Goods and Services identified in the Supply and Installation Cost Sub-Table and the Recurrent Cost Sub-Table in Section VII (Forms 2.5 and 2.6), and all other Goods and Services proposed by the Bidder to fulfill the requirements of the Information System, must be priced separately in the format of the same tables and summarized in the corresponding Cost Summary Tables in the same Section. Prices must be quoted in accordance with the instructions provided in Section VII for the various cost tables, in the manner specified below.
- 14.2 The price of items that the Bidder has left blank in the cost tables provided in Section VII shall be assumed to be included in the price of other items. Items omitted altogether from the cost tables shall be assumed to be omitted from the bid and, provided that the bid is substantially responsive, an adjustment to the bid price will be made during evaluation in accordance with ITB Clause 28.6 (c) (iii).
- 14.3 Unit prices must be quoted at a level of detail appropriate for calculation of any partial deliveries or partial payments under the contract, in accordance with the Implementation Schedule in Section VI, and with GCC and SCC Clause 12 – Terms of Payment. Bidders may be required to provide a breakdown of any composite or lump-sum items included in the Cost Tables.

14.4 The prices for Goods components of the System are to be expressed and shall be defined and governed in accordance with the rules prescribed in the edition of Incoterms **specified in the BDS**, and quoted in the appropriate columns of the cost tables of Section VII as follows:

1. Goods supplied from outside the Purchaser's country:

Unless otherwise **specified in the BDS**, the prices shall be quoted on a CIP (named place of destination) basis, exclusive of all taxes, stamps, duties, levies, and fees imposed in the Purchaser's country. The named place of destination and special instructions for the contract of carriage are as **specified in the BDS**. In quoting the price, the Bidder shall be free to use transportation through carriers registered in any eligible countries. Similarly, the Bidder may obtain insurance services from any eligible source country.

(b) Locally supplied Goods:

Unit prices of Goods offered from within the Purchaser's Country, shall be quoted on an EXW (ex factory, ex works, ex warehouse or off-the-shelf, as applicable) basis, including all customs duties, levies, fees, sales and other taxes incurred until delivery of the Goods, but excluding all VAT or sales and other taxes and duties/fees incurred for the Goods at the time of invoicing or sales transaction, if the Contract is awarded.

(c) Inland transportation:

Unless otherwise **stated in the BDS**, inland transportation, insurance and related local costs incidental to the delivery of the Goods to the designated Project Sites must be quoted separately as a Service item in accordance with ITB Clause 14.5, whether the Goods are to be supplied locally or from outside the Purchaser's country, except when these costs are already included in the price of the Goods, as is, e.g., the case, when ITB Clause 14.4 (a) specifies CIP, and the named places of destination are the Project Sites.

14.5 The price of Services shall be quoted in total for each service (where appropriate, broken down into unit prices), separated into their local and foreign currency components. Prices must include all taxes, duties, levies and fees whatsoever, except only VAT or other indirect taxes, or stamp duties, that may be assessed and/or apply in the Purchaser's country on/to the price of the Services invoiced to the Purchaser, if the Contract is awarded. Unless

otherwise **specified in the BDS**, the prices must include all costs incidental to the performance of the Services, as incurred by the Supplier, such as travel, subsistence, office support, communications, translation, printing of materials, etc. Costs incidental to the delivery of the Services but incurred by the Purchaser or its staff, or by third parties, must be included in the price only to the extent such obligations are made explicit in these Bidding Documents (as, e.g., a requirement for the Bidder to include the travel and subsistence costs of trainees).

- 14.6 Prices for Recurrent Costs beyond the scope of warranty services to be incurred during the Warranty Period, defined in SCC Clause 29.4 and prices for Recurrent Costs to be incurred during the Post-Warranty Period, defined in SCC Clause 1.1. (e) (xii), shall be quoted as Service prices in accordance with ITB Clause 14.5 on the Recurrent Cost Sub-Table in detail, and on the Recurrent Cost Summary Table in currency totals. Recurrent costs are all-inclusive of the costs of necessary Goods such as spare parts, software license renewals, labor, etc., needed for the continued and proper operation of the System and, if appropriate, of the Bidder's own allowance for price increases.
- 14.7 Unless otherwise **specified in the BDS**, prices quoted by the Bidder shall be fixed during the Bidder's performance of the Contract and not subject to increases on any account. Bids submitted that are subject to price adjustment will be rejected.

- 15. Bid Currencies** 15.1 Prices shall be quoted in the following currencies:
- (a) The Bidder may quote its prices for all Information Technologies, associated Goods, and Services to be supplied from outside the Purchaser's Country in the currencies of countries eligible according to Section III. If the Bidder wishes to be paid in a combination of different currencies, it must quote unit prices accordingly, but no more than three foreign currencies may be used.
 - (b) Unless otherwise **specified in the BDS**, the Bidder shall express its prices for such Information Technologies, associated Goods, and Services to be supplied locally (i.e., from within the Purchaser's Country) in the currency of the Purchaser's Country.
- 16. Documents Establishing the Conformity of the Information System to the Bidding Documents** 16.1 Pursuant to ITB Clause 13.1 (e) (iv), the Bidder shall furnish, as part of its bid, documents establishing the conformity to the Bidding Documents of the Information System that the Bidder proposes to supply and install under the Contract.
- 16.2 The documentary evidence of conformity of the Information System to the Bidding Documents shall be in the form of written descriptions, literature, diagrams, certifications, and client references, including:
- (a) the Bidder's technical bid, i.e., a detailed description of the Bidder's proposed technical solution conforming in all material aspects with the Technical Requirements (Section VI) and other parts of these Bidding Documents, overall as well as in regard to the essential technical and performance characteristics of each component making up the proposed Information System;
 - (b) an item-by-item commentary on the Purchaser's Technical Requirements, demonstrating the substantial responsiveness of the Information System offered to those requirements. In demonstrating responsiveness, the commentary shall include explicit cross references to the relevant pages in the supporting materials included in the bid. Whenever a discrepancy arises between the item-by-item commentary and any catalogs, technical specifications, or other preprinted materials submitted with the bid, the item-by-item commentary shall prevail;
 - (c) a Preliminary Project Plan describing, among other things, the methods by which the Bidder will carry out its overall management and coordination responsibilities if awarded

the Contract, and the human and other resources the Bidder proposes to use. The Plan should include a detailed Contract Implementation Schedule in bar chart form, showing the estimated duration, sequence, and interrelationship of all key activities needed to complete the Contract. The Preliminary Project Plan must also address any other topics **specified in the BDS**. In addition, the Preliminary Project Plan should state the Bidder's assessment of what it expects the Purchaser and any other party involved in the implementation of the Information System to provide during implementation and how the Bidder proposes to coordinate the activities of all involved parties;

- (d) a written confirmation that the Bidder accepts responsibility for the successful integration and inter-operability of all components of the Information System as required by the Bidding Documents.

16.3 For purposes of the commentary to be furnished pursuant to ITB Clause 16.2 (b), the Bidder shall note that references to brand names or model numbers or national or proprietary standards designated by the Purchaser in its Technical Requirements are intended to be descriptive and not restrictive. Except where explicitly **prohibited in the BDS** for specific items or standards, the Bidder may substitute alternative brand/model names or standards in its bid, provided that it demonstrates to the Purchaser's satisfaction that the use of the substitute(s) will result in the Information System being able to perform substantially equivalent to or better than that specified in the Technical Requirements.

17. Securing the Bid

17.1 The BDS for this Clause specifies whether bids must be secured, and if so, whether by a Bid-Securing Declaration or by a Bid Security. If a Bid Security is required or optional, the **BDS also specifies the amount**.

17.2 Securing the bids shall be substantially in accordance with the related sample forms included in Section VII or other forms approved by the Purchaser prior to bid submission. Bids must remain secured for a period of 28 days beyond the validity period of the bids, as extended, if applicable, in accordance with ITB Clause 18.2. In case of a Bid Security, it shall also:

- (a) at the Bidder's option, be in the form of either a certified check, letter of credit, or a bank guarantee from a banking institution, or a bond issued by a surety;

- (b) be issued by a reputable institution selected by the Bidder and located in any eligible country; if the institution issuing the security is located outside the Purchaser's Country, it shall have a correspondent financial institution located in the Purchaser's Country to make the security enforceable;
 - (c) be payable promptly upon written demand by the Purchaser in case any of the conditions listed in ITB Clause 17.6 is/are invoked;
 - (d) be submitted in its original form; copies will not be accepted.
- 17.3 The Bid-Securing Declaration or the Bid Security of a Joint Venture shall be issued in the name of the Joint Venture submitting the bid provided the Joint Venture has legally been constituted, or else it shall be issued in the name of all partners proposed for the Joint Venture in the bid. Sanctions due to a breach of the terms of a Bid-Securing Declaration pursuant to ITB Clause 17.6 will apply to all partners to the Joint Venture.
- 17.4 If a Bid-Securing Declaration or Bid Security is required in accordance with ITB Clause 17.1, any bid not accompanied by a substantially acceptable Bid-Securing Declaration or Bid Security in accordance with ITB Clauses 17.2 and 17.3, shall be rejected by the Purchaser as non-responsive.
- 17.5 Unless executed or forfeited pursuant to ITB Clause 17.6, Bid-Securing Declarations, if any, will expire for, or Bid Securities, if any, will be returned as promptly as possible to,
- (a) all Bidders upon annulment of the bidding pursuant to ITB Clause 34;
 - (b) Bidders refusing a request to extend the period of validity of their bids pursuant to ITB Clause 18.2;
 - (c) the successful Bidder once it has signed the Contract Agreement and furnished a valid Performance Security as required;
 - (d) the unsuccessful Bidders at the same time as in (c), that is, when they are informed about the successful establishment of the contract with the successful Bidder.

17.6 The Bid-Securing Declaration, if any, may be executed, or the Bid Security, if any, may be forfeited:

- (a) if a Bidder withdraws its bid during the period of bid validity specified by the Bidder on the Bid Submission Form or any extension of validity the Bidder has agreed to pursuant to ITB Clause 18.2; or
- (b) in the case of the successful Bidder, if the Bidder fails to:
 - (i) sign the Contract Agreement in accordance with ITB Clause 36; or
 - (ii) furnish the Performance Security in accordance with ITB Clause 37.

17.7 If a bid security is **not required in the BDS**, and

- (a) if a Bidder withdraws its bid during the period of bid validity specified by the Bidder on the Letter of Bid Form, except as provided in ITB 18.2, or
- (b) if the successful Bidder fails to: sign the Contract in accordance with ITB 36; or furnish a performance security in accordance with ITB 37;

the Borrower may, **if provided for in the BDS**, declare the Bidder disqualified to be awarded a contract by the Employer for a period of time **as stated in the BDS**.

18. Period of Validity of Bids

18.1 Bids shall remain valid, at a minimum, for the period **specified in the BDS** after the deadline date for bid submission prescribed by the Purchaser, pursuant to ITB Clause 21. A bid valid for a shorter period shall be rejected by the Purchaser as non-responsive. For the convenience of Bidders, the BDS spells out the minimal original expiration dates for the validity of the bid and, if applicable pursuant to ITB Clause 17.1, for securing the bid. However, Bidders are responsible for adjusting the dates in the BDS in accordance with any extensions to the deadline date of bid submission pursuant to ITB Clause 21.2.

18.2 In exceptional circumstances, prior to expiry of the bid validity period, the Purchaser may request that the Bidders extend the period of validity for a specified additional period. The request and the responses to the request shall be made in writing. A Bidder may refuse the request without risking execution of the Bid-Securing Declaration or forfeiting the Bid Security, but in this case the bid will be out of the competition for the award. Except as provided in ITB Clause 18.3, a Bidder agreeing to the request

will not be required or permitted to modify its bid, but will be required to ensure that the bid remains secured for a correspondingly longer period, pursuant to ITB Clause 17.2.

18.3 In the case of fixed price contracts, if the award is delayed by a period exceeding fifty-six (56) days beyond the expiry of the initial bid validity, the contract price will be adjusted as specified in the request for extension. Bid evaluation will be based on the bid prices without taking into consideration the above correction.

19. Format and Signing of Bid

19.1 The Bidder shall prepare an original and the number of copies/sets of the bid **specified in the BDS**, clearly marking each one as “ORIGINAL BID,” “COPY NO. 1,” “COPY NO. 2,” etc., as appropriate. In the event of any discrepancy between them, the original shall govern.

19.2 The original and all copies of the bid, each consisting of the documents listed in ITB Clause 13.1, shall be typed or written in indelible ink and shall be signed by a person or persons duly authorized to sign on behalf of the Bidder. The authorization must be in writing and included in the bid pursuant to ITB Clause 13.1 (d). The name and position held by each person signing the authorization must be typed or printed below the signature. All pages of the bid, except for unamended printed literature, shall be initialed by the person or persons signing the bid.

19.3 The bid shall contain no interlineations, erasures, or overwriting, except to correct errors made by the Bidder, in which case such corrections shall be initialed by the person or persons signing the bid.

19.4 The Bidder shall furnish in the Bid Submission Form (a sample of which is provided in the Sample Forms Section of the Bidding Documents) information regarding commissions or gratuities, if any, paid or to be paid to agents relating to this procurement and to the execution of the Contract should the Bidder be successful.

D. SUBMISSION OF BIDS

20. Sealing and Marking of Bids

20.1 The Bidder shall seal the original and each copy of the bid in separate envelopes, duly marking the envelopes as “ORIGINAL BID” and “COPY NO. [Number].” The envelopes shall then be sealed in an outer envelope.

20.2 The inner and outer envelopes shall

- (a) be addressed to the Purchaser at the address **given in the BDS**, and
 - (b) bear the loan/Project name indicated in the BDS for ITB Clause 2.1, the Invitation for Bids title and number, and the Contract name(s), as indicated in the BDS for ITB Clause 1.2, and the statement “DO NOT OPEN BEFORE [*time and date*],” to be completed with the time and date specified in the BDS for ITB Clause 24.1.
- 20.3 The inner envelopes shall also indicate the name and address of the Bidder so that the bid can be returned unopened in case it is declared “late.”
- 20.4 If the outer envelope is not sealed and marked as required by ITB Clause 20.2 above, the Purchaser will assume no responsibility for the bid’s misplacement or premature opening. If the outer envelope discloses the Bidder’s identity, the Purchaser will not guarantee the anonymity of the bid submission, but this disclosure will not constitute grounds for bid rejection.
- 21. Deadline for Submission of Bids**

 - 21.1 Bids must be received by the Purchaser at the address specified in the BDS for ITB Clause 20.2 no later than the time and date **stated in the BDS**.
 - 21.2 The Purchaser may, at its discretion, extend this deadline for submission of bids by amending the Bidding Documents in accordance with ITB Clause 11.3, in which case all rights and obligations of the Purchaser and Bidders will thereafter be subject to the deadline as extended.
- 22. Late Bids**

 - 22.1 Any bid received by the Purchaser after the bid submission deadline prescribed by the Purchaser in the BDS for ITB Clause 21, will be rejected and returned unopened to the Bidder.
- 23. Withdrawal, Substitution, and Modification of Bids**

 - 23.1 The Bidder may withdraw, substitute, or modify its bid after submission, provided that written notice of the withdrawal, substitution, or modification is received by the Purchaser prior to the deadline prescribed for bid submission. All notices must be duly signed by an authorized representative and shall include a copy of the authorization (the power of attorney) in accordance with ITB Sub-Clause 19.2.
 - 23.2 All notices of withdrawal, substitution, or modification shall
 - (a) be addressed to the Purchaser at the address named in the BDS for ITB Clause 20.2 (a), and

- (b) bear the Contract name, the IFB Title and IFB Number, and the words “BID WITHDRAWAL NOTICE”, BID SUBSTITUTION NOTICE”, or “BID MODIFICATION NOTICE”.

23.3 A notice may also be sent by electronic means such as fax or e-mail, but in this case must include a scan of the mailing receipt showing both the sender's and receiver's addresses for the signed hardcopy of the notice, and a scan of the power of attorney.

23.4 Bids requested to be withdrawn in accordance with ITB 23.1 shall be returned unopened to the Bidders. Bid withdrawal notices received after the bid submission deadline will be ignored, and the submitted bid will be deemed to be a validly submitted bid.

23.5 The substitution or modification of the bid shall be prepared, sealed, marked, and dispatched as follows:

- (a) The Bidders shall provide an original and the number of copies specified in the BDS for ITB Clause 19.1 of any substitution or modification to its bid, clearly identified as such, in two inner envelopes duly marked “BID SUBSTITUTION -- ORIGINAL” or “BID MODIFICATION -- ORIGINAL” and “BID SUBSTITUTION -- COPIES” or “BID MODIFICATION -- COPIES.” The inner envelopes shall be sealed in an outer envelope, which shall be duly marked “BID SUBSTITUTION” or “BID MODIFICATION”.
- (b) Other provisions concerning the marking and dispatch of a bid substitution or modification shall be in accordance with ITB Clauses 20.2, 20.3, and 20.4.

23.6 No bid may be withdrawn, substituted, or modified in the interval between the bid submission deadline and the expiration of the bid validity period specified by the Bidder in the Bid Submission Form, or any extension thereof agreed to by the Bidder. Withdrawal of a bid during this interval may result in the execution of the Bid-Securing Declaration, if any, or forfeiture of the Bid Security, if any, pursuant to ITB Clause 17.6.

E. BID OPENING AND EVALUATION

- 24. Opening of Bids by Purchaser** 24.1 The Purchaser will open all bids, including withdrawals, substitutions, and modifications, in public, in the presence of Bidders’ representatives who choose to attend, at the time, on the date and at the place **specified in the BDS**. Bidders’ representatives shall sign a register as proof of their attendance.

- 24.2 First, envelopes marked “BID WITHDRAWAL NOTICE” shall be opened and read out and the envelope with the corresponding bid shall not be opened, but returned to the Bidder. No bid withdrawal shall be permitted unless the corresponding withdrawal notice contains a valid authorization to request the withdrawal and is read out at bid opening. Next, envelopes marked “BID SUBSTITUTION NOTICE” shall be opened and read out and exchanged with the corresponding bid being substituted, and the substituted bid shall not be opened, but returned to the Bidder. No bid substitution shall be permitted unless the corresponding substitution notice contains a valid authorization to request the substitution and is read out at bid opening. Envelopes marked “BID MODIFICATION NOTICE” shall be opened and read out with the corresponding bid. No bid modification shall be permitted unless the corresponding modification notice contains a valid authorization to request the modification and is read out at bid opening. Only bids that are opened and read out at bid opening shall be considered further.
- 24.3 Bids shall be opened one at a time, reading out: the name of the Bidder and whether there is a modification; the total bid price including any unconditional discounts, and, if applicable, the prices and unconditional discounts for Subsystems, lots, or slices; the presence or absence of a Bid-Securing Declaration or a Bid Security if one was required; any conditional discounts offered for the award of more than one Subsystem, lot, or slice, if the BDS for ITB Clause 28.1 permits such discounts to be considered in the bid evaluation; and any other such details as the Purchaser may consider appropriate.
- 24.4 Bids and modifications that are not opened and read out at bid opening shall not be considered for further evaluation, irrespective of the circumstances. These bids, including any bids validly withdrawn in accordance with ITB Clause 24.2, will promptly be returned, unopened, to their Bidders.
- 24.5 The Purchaser will prepare minutes of the bid opening, including the information disclosed to those present in accordance with ITB Clause 24.3. The minutes will promptly be distributed to all Bidders that met the deadline for submitting bids.
- 25. Clarification of Bids**
- 25.1 During the bid evaluation, the Purchaser may, at its discretion, ask the Bidder for a clarification of its bid. The request for clarification and the response shall be in writing, and no change in the price or substance of the bid shall be sought, offered, or permitted.

26. Preliminary Examination of Bids

- 26.1 The Purchaser will examine the bids to determine whether they are complete, whether any computational errors have been made, whether required sureties have been furnished, whether the documents have been properly signed, and whether the bids are generally in order. In the case where a prequalification process has been undertaken for the Contract(s) for which these Bidding Documents have been issued, the Purchaser will ensure that each bid is from a prequalified Bidder, and in the case of a Joint Venture, that partners and structure of the Joint Venture are unchanged from those in the prequalification.
- 26.2 Arithmetical errors will be rectified on the following basis. If there is a discrepancy between the unit price and the total price, which is obtained by multiplying the unit price and quantity, or between added or subtracted subtotals and totals, the unit or subtotal price shall prevail and the total price shall be corrected, unless in the opinion of the Purchaser there is an obvious misplacement of the decimal point in the unit or subtotal prices, in which case the line item total as quoted shall govern and the unit price or sub-total shall be corrected. If there is a discrepancy between words and figures, the amount in words will prevail, unless the discrepancy is the result of a typo/error for which the correction is self-evident to the Purchaser. If the Bidder with the Lowest Evaluated Bid does not accept the correction of errors, the bid shall be rejected.
- 26.3 The Purchaser may waive any minor informality, nonconformity, or irregularity in a bid that does not constitute a material deviation, provided such waiver does not prejudice or affect the relative ranking of any Bidder.
- 26.4 Prior to the detailed evaluation, the Purchaser will determine whether each bid is of acceptable quality, is complete, and is substantially responsive to the Bidding Documents. For purposes of this determination, a substantially responsive bid is one that conforms to all the terms, conditions, and specifications of the Bidding Documents without material deviations, exceptions, objections, conditionalities, or reservations. A material deviation, exception, objection, conditionality, or reservation is one: (i) that limits in any substantial way the scope, quality, or performance of the Information System; or (ii) that limits, in any substantial way that is inconsistent with the Bidding Documents, the Purchaser's rights or the successful Bidder's obligations under the Contract; or (iii) the acceptance of which would unfairly affect the competitive position of other Bidders who have submitted substantially responsive bids.

- 26.5 If a bid is not substantially responsive, it will be rejected by the Purchaser and may not subsequently be made responsive by the Bidder by correction of the nonconformity. The Purchaser's determination of bid responsiveness will be based on the contents of the bid itself.
- 27. Conversion to Single Currency** 27.1 For evaluation and comparison purposes, the Purchaser shall convert all bid prices expressed in various currencies and amounts into a single currency **specified in the BDS**, using the selling exchange rate established by the source and on the date also **specified in the BDS**.
- 28. Evaluation and Comparison of Bids** 28.1 The Purchaser will evaluate and compare the bids that have been determined to be substantially responsive, pursuant to ITB Clause 26. The evaluation will be performed assuming either that:
- (a) the Contract will be awarded to the lowest evaluated Bidder for the entire Information System; or
 - (b) if **specified in the BDS**, Contracts will be awarded to the Bidders for each individual Subsystem, lot, or slice defined in the Technical Requirements whose bids result in the lowest combined evaluated price for the entire System.
- In the latter case, discounts that are conditional on the award of more than one Subsystem, lot, or slice may be offered in bids. However, such discounts will only be considered in the price evaluation if so **confirmed in the BDS**.
- 28.2 To be considered for Contract award, Bidders must have submitted bids
- (a) for which detailed bid evaluation using the same standards for compliance determination as listed in ITB Clauses 26.3 and 26.4 confirms that the bids are commercially and technically responsive, and include the hardware, Software, related equipment, products, Materials, and other Goods and Services components of the Information System in, substantially, the full required quantities for the entire Information System or, if allowed in the BDS for ITB Clause 28.1, the individual Subsystem, lot or slice bid on; and
 - (b) that offer Information Technologies that are proven to perform up to the standards promised in the bid by having successfully passed the performance, benchmark, and/or functionality tests the Purchaser may require, pursuant to ITB Clause 31.2.

28.3 The Purchaser's evaluation of a bid will be made on the basis of prices quoted in accordance with ITB Clause 14 (Bid Prices).

28.4 If **indicated by the BDS**, the Purchaser's evaluation of responsive bids will take into account technical factors, in addition to cost factors. An Evaluated Bid Score (B) will be calculated for each responsive bid using the following formula, which permits a comprehensive assessment of the bid price and the technical merits of each bid:

$$B \equiv \frac{C_{low}}{C} X + \frac{T}{T_{high}} (1 - X)$$

where

C = Evaluated Bid Price

C_{low} = the lowest of all Evaluated Bid Prices among responsive bids

T = the total Technical Score awarded to the bid

T_{high} = the Technical Score achieved by the bid that was scored highest among all responsive bids

X = weight for the Price as **specified in the BDS**

The bid with the highest Evaluated Bid Score (B) among responsive bids shall be termed the Lowest Evaluated Bid and is eligible for Contract award, provided the Bidder was prequalified and/or it was found to be qualified to perform the Contract in accordance with ITB Clause 31 (Post qualification).

28.5 If, in addition to the cost factors, the Purchaser has chosen to give weight to important technical factors (i.e., the price weight, X, is less than 1 in the evaluation), that cannot be reduced to life-cycle costs or pass/fail criteria, the Total Technical Points assigned to each bid in the Evaluated Bid Formula will be determined by adding and weighting the scores assigned by an evaluation committee to technical features of the bid in accordance with the criteria set forth below.

(a) The technical features to be evaluated are generally defined below and specifically **identified in the BDS**:

(i) Performance, capacity, or functionality features that either exceed levels specified as mandatory in the Technical Requirements; and/or influence the life-

- cycle cost and effectiveness of the Information System.
- (ii) Usability features, such as ease of use, ease of administration, or ease of expansion, which influence the life-cycle cost and effectiveness of the Information System.
 - (iii) The quality of the Bidder's Preliminary Project Plan as evidenced by the thoroughness, reasonableness, and responsiveness of: (a) the task and resource schedules, both general and specific, and (b) the proposed arrangements for management and coordination, training, quality assurance, technical support, logistics, problem resolution, and transfer of knowledge, and other such activities as specified by the Purchaser in Section VI (Technical Requirements) or proposed by the Bidder based on the Bidder's experience.
- (b) Feature scores will be grouped into a small number of evaluation categories, generally defined below and specifically **identified in the BDS**, namely:
- (i) The technical features that reflect how well the Information System meets the Purchaser's Business Requirements (including quality assurance and risk-containment measures associated with the implementation of the Information System).
 - (ii) The technical features that reflect how well the Information System meets the System's Functional Performance Standards.
 - (iii) The technical features that reflect how well the Information System meets the General Technical Requirements for hardware, network and communications, Software, and Services.
- (c) As **specified in the BDS**, each category will be given a weight and within each category each feature may also be given a weight.
- (d) During the evaluation process, the evaluation committee will assign each desirable/preferred feature a whole number score from 0 to 4, where 0 means that the feature is absent, and 1 to 4 either represent predefined values for desirable features amenable to an objective way of rating (as is the

case for, e.g., extra memory, or extra mass storage capacity, etc., if these extras would be conducive for the utility of the system), or if the feature represents a desirable functionality (e.g., of a software package) or a quality improving the prospects for a successful implementation (such as the strengths of the proposed project staff, the methodology, the elaboration of the project plan, etc., in the bid), the scoring will be 1 for the feature being present but showing deficiencies; 2 for meeting the requirements; 3 for marginally exceeding the requirements; and 4 for significantly exceeding the requirements.

- (e) The score for each feature (i) within a category (j) will be combined with the scores of features in the same category as a weighted sum to form the Category Technical Score using the following formula:

$$S_j \equiv \sum_{i=1}^k t_{ji} * w_{ji}$$

where:

t_{ji} = the technical score for feature “i” in category “j”

w_{ji} = the weight of feature “i” in category “j”

k = the number of scored features in category “j”

and
$$\sum_{i=1}^k w_{ji} = 1$$

- (f) The Category Technical Scores will be combined in a weighted sum to form the total Technical Bid Score using the following formula:

$$T \equiv \sum_{j=1}^n S_j * W_j$$

where:

S_j = the Category Technical Score of category “j”

W_j = the weight of category “j” as **specified in the BDS**

n = the number of categories

and
$$\sum_{j=1}^n W_j = 1$$

28.6 The Evaluated Bid Price (C) for each responsive bid will be determined as the sum of the Adjusted Supply and Installation Costs (P) plus the Recurrent Costs (R);

where the Adjusted Supply and Installation Costs (P) are determined as:

- (a) The price of the hardware, Software, related equipment, products, Materials and other Goods offered from within or from outside the Purchaser's Country, in accordance with ITB 14.4; plus
- (b) The total price for all software development, transportation, insurance, installation, customization, integration, Commissioning, testing, training, technical support, repair, and other Services, in accordance with ITB 14.5;
- (c) with adjustments for:
 - (i) Deviations proposed to the Implementation Schedule in the Technical Requirements resulting in delayed completion of the entire Information System, if **permitted in the BDS** and provided they do not exceed the maximum permissible delay period **specified in the BDS**. For evaluation purposes, a pro rata increase of the total Supply and Installation Costs will be added using the percentage(s) **specified in the BDS** for each week of delay. Bids offering deliveries beyond the maximum permissible delay specified may be rejected.
 - (ii) Deviations taken to the Contract payment schedule specified in the SCC. If deviations are **permitted in the BDS**, for evaluation purposes the total Supply and Installation Costs will be increased pro rata by the amount of interest that could otherwise be earned on the amount of any payments that would fall due under the proposed schedule earlier than the schedule stipulated in the SCC, at the interest rate **specified in the BDS**.
 - (iii) Goods and Services that are required for the Information System but have been left out or are necessary to correct minor deviations of the bid will be added to the total Supply and Installation Costs using costs taken from the highest prices from other responsive bids for the same Goods and Services, or in the absence of such information, the cost will be

estimated at prevailing list prices. If the missing Goods and Services are a scored technical feature, the relevant score will be set at zero.

- (iv) Corrections to errors in arithmetic, in accordance with ITB Clause 26.2.
 - (v) Any discounts offered for the award of more than one Subsystem, lot, or slice, if the BDS for ITB Clause 28.1 permits the consideration of discounts in the price evaluation.
- (d) The Recurrent Costs (R) are reduced to net present value and determined using the following formula:

$$R \equiv \sum_{x=1}^{N+M} \frac{R_x}{(1+I)^x}$$

where

N = number of years of the Warranty Period, defined in SCC Clause 29.4

M = number of years of the Post-Warranty Services Period, as defined in SCC Clause 1.1. (e) (xii)

x = an index number 1, 2, 3, ... $N + M$ representing each year of the combined Warranty Service and Post-Warranty Service Periods.

R_x = total Recurrent Costs for year “ x ,” as recorded in the Recurrent Cost Sub-Table.

I = discount rate to be used for the Net Present Value calculation, as **specified in the BDS**.

29. Domestic Preference

29.1 No margin of domestic preference will apply.

30. Contacting the Purchaser

30.1 From the time of bid opening to the time of Contract award, if any Bidder wishes to contact the Purchaser on any matter related to the bid, it should do so in writing.

30.2 If a Bidder tries to directly influence the Purchaser or otherwise interfere in the bid evaluation process and the Contract award decision, its bid may be rejected.

F. POST QUALIFICATION AND AWARD OF CONTRACT

- 31. Post qualification**
- 31.1 The Purchaser will determine at its own cost and to its satisfaction whether the Bidder (including Joint Venture Partners, and any Subcontractors for which the BDS for ITB Clause 6.1 (a) permits that their qualifications count towards the required Bidder qualifications) that is selected as having submitted the Lowest Evaluated Bid is qualified to perform the Contract satisfactorily, in accordance with ITB Clause 6. If a prequalification process was undertaken for the Contract(s) for which these Bidding Documents were issued, the Purchaser will determine in the manner described above that no material changes have occurred after the prequalification that negatively affect the ability of the Bidder that has submitted the Lowest Evaluated Bid to perform the Contract.
- 31.2 Pursuant to ITB Clauses 6 and 16, and as additionally may be **specified in the BDS**, the determination will evaluate the Bidder's financial, technical, design, integration, customization, production, management, and support capabilities and will be based on an examination of the documentary evidence of the Bidder's qualifications, as well as other information the Purchaser deems necessary and appropriate. This determination may include visits or interviews with the Bidder's clients referenced in its bid, site inspections, and any other measures. If so **specified in the BDS**, at the time of post qualification the Purchaser may also carry out tests to determine that the performance or functionality of the Information System offered meets those stated in the Technical Requirements.
- 31.3 An affirmative post qualification determination will be a prerequisite for award of the Contract to the Lowest Evaluated Bidder. A negative determination will result in rejection of the Bidder's bid, in which event the Purchaser will proceed to the next lowest evaluated Bidder to make a similar determination of that Bidder's capabilities to perform satisfactorily.
- 32. Award Criteria**
- 32.1 Subject to ITB Clause 34, the Purchaser will award the Contract to the Bidder whose bid has been determined to be substantially responsive and the Lowest Evaluated Bid, provided further that the Bidder has been determined to be qualified to perform the Contract satisfactorily, pursuant to ITB Clause 31.
- 33. Purchaser's Right to Vary Quantities at Time of Award**
- 33.1 The Purchaser reserves the right at the time of Contract award to increase or decrease, by the percentage(s) **indicated in the BDS**, any of the following:

- (a) the quantity of substantially identical Subsystems; or
- (b) the quantity of individual hardware, Software, related equipment, Materials, products, and other Goods components of the Information System; or
- (c) the quantity of Installation or other Services to be performed,

from that originally specified in the Technical Requirements (as amended by any Addenda issued pursuant to ITB Clause 11), without any change in unit prices or other terms and conditions.

**34. Purchaser's
Right to Accept
Any Bid and to
Reject Any or
All Bids**

34.1 The Purchaser reserves the right to accept or reject any bid or to annul the bidding process and reject all bids at any time prior to Contract award, without thereby incurring any liability to the Bidders.

**35. Notification of
Award**

35.1 Prior to the expiration of the period of bid validity, the Purchaser shall notify the successful Bidder, in writing, that its bid has been accepted.

35.2 Until a formal Contract is prepared and executed, the notification of award shall constitute a binding Contract.

35.3 The Purchaser shall promptly publish in UNDB online and in dgMarket the results, identifying the bid and lot numbers and the following information: (i) name of each Bidder who submitted a bid; (ii) bid prices as read out at bid opening; (iii) name, evaluated price and, if the bidding conditions included scoring for technical quality, the technical score of each bid that was evaluated; (iv) name of Bidders whose bids were rejected and the reasons for their rejection; and (v) name of the winning Bidder, the price it offered, as well as the duration and summary scope of the contract awarded. After publication of the award, unsuccessful Bidders may make a request in writing to the Purchaser for a debriefing seeking explanations on the grounds on which their bids were not selected. The Purchaser shall promptly respond in writing to any unsuccessful Bidder who, after publication of contract award, requests a debriefing.

35.4 Upon the successful Bidder furnishing the signed Contract Agreement and the Performance Security pursuant to ITB Clause 37, the Purchaser will promptly notify each unsuccessful Bidder, and will discharge all remaining Bid Securities, if any, as provided in ITB Clause 17.5 (c) and (d).

- 36. Signing of Contract**
- 36.1 At the same time as the Purchaser notifies the successful Bidder that its bid has been accepted, the Purchaser will send the Bidder the Contract Agreement provided in the Bidding Documents, incorporating all agreements between the parties.
- 36.2 As soon as practically possible, but no more than twenty-eight (28) days following receipt of the Contract Agreement, the successful Bidder shall sign and date it, and return it to the Purchaser.
- 37. Performance Security**
- 37.1 As soon as practically possible, but no more than twenty-eight (28) days following receipt of notification of award from the Purchaser, the successful Bidder shall furnish the Performance Security in accordance with the GCC, using the Performance Security form provided in the Bidding Documents or another form acceptable to the Purchaser.
- 37.2 Failure of the successful Bidder to comply with the requirements of ITB Clause 36 or ITB Clause 37.1 shall constitute sufficient grounds for the annulment of the award and, if and as applicable, execution of the Bid-Securing Declaration or forfeiture of the Bid Security, in which event the Purchaser may make the award to the next lowest evaluated bid submitted by a qualified Bidder or call for new bids.
- 38. Adjudicator**
- 38.1 Unless otherwise **stated in the BDS**, the Purchaser proposes that the person named in the BDS be appointed as Adjudicator under the Contract to assume the role of informal Contract dispute mediator, as described in GCC Clause 6. In this case, a résumé of the named person is **attached to the BDS**. The proposed hourly fee for the Adjudicator is **specified in the BDS**. The expenses that would be considered reimbursable to the Adjudicator are also **specified in the BDS**. If a Bidder does not accept the Adjudicator proposed by the Purchaser, it should state its non-acceptance in its Bid Submission Form and make a counterproposal of an Adjudicator and an hourly fee, attaching a résumé of the alternative. If the successful Bidder and the Adjudicator nominated in the BDS happen to be from the same country, and this is not the country of the Purchaser too, the Purchaser reserves the right to cancel the Adjudicator nominated in the BDS and propose a new one. If by the day the Contract is signed, the Purchaser and the successful Bidder have not agreed on the appointment of the Adjudicator, the Adjudicator shall be appointed, at the request of either party, by the Appointing Authority specified in the SCC clause relating to GCC Clause 6.1.4, or if no Appointing Authority is specified there, the Contract will be implemented without an Adjudicator.

SECTION II. BID DATA SHEET (BDS)

Bid Data Sheet

The following specific information relating to the System to be procured and the procurement procedures that will be used shall complement, supplement, or amend the provisions in the Instructions to Bidders (ITB). Whenever there is a conflict, the provisions in the Bid Data Sheet (BDS) shall prevail over those in the ITB.

A. GENERAL

ITB 1.1	<p>Name of Purchaser: KENYA REVENUE AUTHORITY (KRA)</p> <p>Name of authorized Purchasing Agent: NONE</p> <p>Description of the System/ Works for which bids are invited:</p> <p>LOT 1: DESIGN, SUPPLY, INSTALLATION, CONFIGURATION AND COMMISSIONING OF A FIBER OPTIC BASED METROPOLITAN AREA NETWORK (MAN) AND LOCAL AREA NETWORKS (LANs) IN KILINDINI PORT.</p> <p>LOT 2: DESIGN, SUPPLY, INSTALLATION, CONFIGURATION AND COMMISSIONING OF AN ENTERPRISE NETWORK MANAGEMENT AND WAN OPTIMISATION SOLUTION</p>
ITB 1.2	<p>Title of IFB: IMPROVEMENT OF KRA ICT CONNECTIVITY INFRASTRUCTURE AT KILINDINI PORT.</p> <p>IFB No: KE-KRA-102514-GO-RFB</p> <p>Name of resulting Contract(s): KE-KRA-102514-GO-RFB IMPROVEMENT OF KRA ICT CONNECTIVITY INFRASTRUCTURE AT KILINDINI PORT.</p>
ITB 1.4	<p>Alternative e-Tendering procedures: Submission of bids shall strictly be done through the KRA E-Procurement Portal. Prospective bidders should register for E-Procurement by clicking on “New Supplier Registration” found under the E - Procurement Tab on KRA’s website; www.kra.go.ke. For assistance on the Supplier Portal or Registration visit any KRA Procurement office Countrywide or email: srmsupport@kra.go.ke. Completed bids are to be saved as PDF files named with the relevant tender description and submitted to the appropriate KRA E-procurement Web Portal found on the KRA website so as to be received on or before 28th June, 2019 at 1100 hrs.</p>
ITB 2.1	<p>Name of the Borrower: GOVERNMENT OF KENYA (GOK).</p>

	<p>Loan or credit number: IBRD/IDA: P148853</p> <p>Loan or credit amount: US\$ 500M</p> <p>Name of Project: EASTERN AFRICA REGIONAL TRADE AND TRANSPORT FACILITATION PROJECT (EARTTDFP).</p>
ITB 6.1 (a)	<p>Evidence for the following qualification requirements shall be attached:</p> <p>1. General and Specific Contract Experience:</p> <p>1.1 The bidder shall have minimum of five years' general experience in the sector;</p> <p>1.2 Successful delivery of contracts involving the development, installation, and provision of technical support for Information Systems of similar functional/technical characteristics and of a comparable scale of one similar contracts of value at least USD one million (USD1 million), within the last five years, to qualify for each lot;</p> <p>2. Financial Capacity and Experience of Minimum:</p> <p>2.1 Average annual turnover of USD 1 million within the last five years (to qualify for each lot);</p> <p>2.2 Access to liquidity of at least USD1.0 million for Lot 1 and USD 650,000 for Lot 2;</p> <p>3. Resources Requirement:</p> <p>3.1 Project manager for Lot 1: Having minimum of MSc degree in ICT or Project management or similar discipline with eight years of work experience of which at least three are as project manager on fiber optics projects;</p> <p>Project Manager for Lot 2: A minimum of a Degree in IT, Comp Science, Mathematics or similar discipline with eight years of work experience of which at least three are as a project manager on delivery and installation of similar software solutions.</p> <p>3.2 5 key technical staffs for each lot with; Lot 1: Minimum of at least 3 year's work experience in laying of fiber connections, be in possession of Degree/ Diploma in Telecommunication/ Electrical Engineering or ICT Networking background; and be in possession of</p>

	<p>certification from recognized institute in Certified Fiber Optic Network Design or any other relevant certification.</p> <p>Lot 2: Minimum of at least 3 year's work experience in installing similar software solutions and be in possession of Degree in IT, Comp Science, Mathematics or similar discipline;</p> <p>4. Client Reference</p> <p>At least two (2) client reference or certificate of successful delivery of similar contracts delivered in the last three years should be attached for both lots.</p>
ITB 6.1 (b)	<p>Manufacturer's Authorizations for Information Technologies - except for those technologies which the Bidder itself manufactures - are required for the following types/categories:</p> <p>1) ACTIVE DEVICES/ COMPONENTS e.g. SWITCHES, ROUTERS ETC.</p> <p>2) PASSIVE DEVICES/ COMPONENTS e.g. CABLES, CABINETS ETC.</p>
ITB 6.1 (c)	<p>If the Bidder proposes to use Subcontractors for the provision of certain key services, written agreements by the proposed firms to provide these services in case of contract(s) resulting from this bidding are required for the following types/categories of services: NONE.</p>

B. THE BIDDING DOCUMENTS

ITB 10.1	<p>Purchaser's / duly authorized Purchasing Agent's address:</p> <p>COMMISSIONER GENERAL</p> <p>ADDRESS: HAILE SELASSIE AVENUE, TIMES TOWER BUILDING</p> <p>FLOOR: 25TH FLOOR - SUPPLY CHAIN MANAGEMENT OFFICE</p> <p>CITY: NAIROBI</p> <p>TELEPHONE: +254 709012374</p> <p>FACSIMILE NUMBER: +254 20 215809</p>
----------	---

	ELECTRONIC MAIL ADDRESS: eprocurement@kra.go.ke
ITB 10.2	Dates, times, and places for the pre-bid meeting: A pre-bid briefing for both Lot 1 and Lot 2 will be conducted on 11th June, 2019 and 13th June, 2019 at 08:30 am . A mandatory site survey for Lot 1 shall be conducted in two groups on Tuesday, 11th June, 2019 and Thursday, 13th June, 2019 at Kilindini Port in Mombasa, Kenya . Each site survey is expected to take two days. Bidders will converge at Forodha House, Mombasa at 8.30 am EAT on 11th June, 2019 and 8.30 am EAT on 13th June, 2019 respectively before proceeding to the site. Bidders who plan to attend the survey/pre-bid briefing should send an email to eprocurement@kra.go.ke indicating their preferred slot for planning purposes.

C. PREPARATION OF BIDS

ITB 12.1	The language of the bid and of all correspondence and documents related to it is: ENGLISH .
ITB 14.1	Recurrent cost items are NOT required.
ITB 14.4	The Incoterms edition is: INCOTERMS 2010 — ICC OFFICIAL RULES FOR THE INTERPRETATION OF TRADE TERMS” PUBLISHED IN SEPTEMBER 1999 BY THE INTERNATIONAL CHAMBER OF COMMERCE, 38 COURS ALBERT 1ER, 75008 PARIS, FRANCE.
ITB 14.4 (a)	For foreign goods priced on a CIP (named place of destination) basis: <ul style="list-style-type: none"> (i) The contract of carriage shall include the cost of unloading the goods at destination, as well as payment by the Supplier of the cost of custom formalities, duties, taxes or other charges payable on the foreign Goods for their transit through any country other than the Purchaser's country. (ii) The named place of destination shall be the: <p>LOT 1: KILINDINI PORT, KENYA.</p> <p>LOT 2: KRA DATA CENTERS IN NAIROBI AND TEN (10) OTHER SELECTED LOCATIONS</p>
ITB 14.7	Prices quoted by the Bidder shall be FIXED .
ITB 15.1 (b)	The currency to be used for quoting prices of the Goods and Services components of the System offered locally (i.e., from within the Purchaser's Country), as well as local currency

	<p>expenditures for local technical support, training, maintenance, transportation, insurance, and other local services incidental to delivery, installation and operation of the System, is: KENYA SHILLINGS (KES) OR UNITED STATES DOLLAR (USD).</p>
ITB 16.2 (c)	<p>In addition to the topics described in ITB Clause 16.2 (c), the Preliminary Project Plan must address the following topics: NONE.</p>
ITB 16.3	<p>In the interest of effective integration, cost-effective technical support, and reduced re-training and staffing costs, Bidders are required to offer specific brand names and models for the following limited number of specific items: NONE.</p>
ITB 17.1	<p>Bids NEED to be secured BY A BID SECURITY.</p> <p>The amount of Bid Security required is: ONE MILLION SHILLINGS ONLY (KES. 1,000,000.00) FOR LOT 1 AND FIVE HUNDRED THOUSAND SHILLINGS ONLY (KES. 500,000.00) FOR LOT 2 OR AN EQUIVALENT AMOUNT IN A FREELY CONVERTIBLE CURRENCY FIXED AMOUNT AND CURRENCY.</p> <p>NB: The physical original bid security is to be submitted in the tender box on the Ground Floor of Times Tower Building. Late bid security will be rejected and thus invalidating the respective bid.</p>
ITB 17.7	<p>If the Bidder incurs any of the actions prescribed in ITB Clause 17.7 (a) or (b), the Borrower will declare the Bidder ineligible to be awarded contracts by the Employer for a period of THREE (3) years.</p>
ITB 18.1	<p>The bid validity period shall be ONE HUNDRED AND EIGHTY (180) days after the deadline for bid submission, as specified below in reference to ITB Clause 21. Accordingly, each bid shall be valid through 25TH DECEMBER, 2019.</p> <p>Accordingly, a bid with a BID SECURITY that expires before 25TH DECEMBER, 2019 shall be rejected as non-responsive.</p>
ITB 19.1	<p>Required number of bid copies, besides the original: NONE (0).</p>

D. SUBMISSION OF BIDS

ITB 20.2 (a)	<p>The address for bid submission is:</p> <p>Submission of bids shall strictly be done through the KRA E-Procurement Portal. Prospective bidders should register on KRA's website; www.kra.go.ke by clicking on "New Supplier Registration" found under the E - Procurement Tab. For assistance on the supplier portal or registration, visit any KRA Procurement Office countrywide or email: srmsupport@kra.go.ke. Completed bids are to be saved as PDF files named with the relevant tender description and submitted in the KRA E-procurement Web Portal so as to be received on or before 28th June, 2019 at 1100 hrs.</p> <p>Responsible Officer: PROJECT MANAGER</p>
ITB 21.1	<p>Deadline for bid submission is: FRIDAY, 28TH JUNE, 2019 TIME: 1100hrs EAT Time</p>

E. BID OPENING AND EVALUATION

ITB 24.1	<p>Time, date, and place for bid opening are:</p> <p>Street Address: HAILE SELASIE AVENUE, TIMES TOWER BUILDING</p> <p>Floor /Room Number: GROUND FLOOR (iSUPPORT OFFICE OFFICE)</p> <p>City: NAIROBI</p> <p>Country: KENYA</p> <p>Date: FRIDAY, 28TH JUNE, 2019</p> <p>Time: 1100hrs EAT Time</p>
ITB 27.1	<p>The currency chosen for the purpose of converting to a common currency is: KENYA SHILLING (KES).</p> <p>The source of exchange rate is: THE CENTRAL BANK OF KENYA.</p> <p>The date of exchange rate determination is: FRIDAY, 28TH JUNE, 2019. In case that no exchange rates are available on this date</p>

	from the source indicated above, the latest available exchange rates from the same source prior to this date will be used.
ITB 28.1	Bids for lots (lot=by lot) WILL be accepted.
ITB 28.4	The bid evaluation WILL NOT take into account technical factors in addition to cost factors. The Lowest Evaluated Bid that meets all the minimum technical specifications and requirements specified and that meets minimum qualification criteria will be the awardee.
ITB 28.6 (c) (i)	The Purchaser WILL NOT accept deviations in the schedule of installation and commissioning specified in the Implementation Schedule.
ITB 28.6 (c) (ii)	The Purchaser WILL NOT accept deviations in the payment schedule in the SCC.
ITB 29.1	Margin of domestic preference WILL NOT apply.

F. POST QUALIFICATION AND AWARD OF CONTRACT

ITB 31.2	In order to qualify and be awarded multiple lots, the successful bidder has to meet the aggregate post qualification requirements for all the lots.
ITB 33.1	Percentage for quantity increase or decrease: FIFTEEN (15%) PERCENT FOR LOT 1 ONLY.
ITB 38.1	The proposed Adjudicator: SHALL BE APPOINTED BY THE KENYA NATIONAL CHAMBER OF COMMERCE AND INDUSTRY.

**SECTION III. ELIGIBLE COUNTRIES FOR THE PROVISION OF
GOODS, WORKS, AND SERVICES IN BANK-FINANCED
PROCUREMENT**

Eligible Countries for the Provision of Goods, Works, and Services in Bank-Financed Procurement

As of September 2007

1. Eligible for this procurement are firms of, and goods manufactured in, all countries except countries, if any, listed in the following restrictions.
2. In accordance with para. 1.8 (a) of the Guidelines: Procurement under IBRD Loans and IDA Credits, firms of a Country or goods manufactured in a Country may be excluded if
 - (i) as a matter of law or official regulation, the Borrower's Country prohibits commercial relations with that Country, provided that the Bank is satisfied that such exclusion does not preclude effective competition for the supply of the goods or works required, or
 - (ii) by an Act of Compliance with a Decision of the United Nations Security Council taken under Chapter VII of the Charter of the United Nations, the Borrower's Country prohibits any import of goods from that Country or any payments to persons or entities in that Country.
3. For the information of borrowers and bidders, at the present time firms, goods and services from the following countries are excluded from this bidding:

With reference to paragraph (i) above: **NONE**

With reference to paragraph (ii) above: **NONE**

SECTION IV. GENERAL CONDITIONS OF CONTRACT

Table of Clauses

A. Contract and Interpretation	58
1. Definitions.....	58
2. Contract Documents.....	66
3. Interpretation.....	66
4. Notices	68
5. Governing Law	69
6. Settlement of Disputes	69
B. Subject Matter of Contract	72
7. Scope of the System.....	72
8. Time for Commencement and Operational Acceptance	72
9. Supplier’s Responsibilities.....	73
10. Purchaser’s Responsibilities	75
C. Payment.....	77
11. Contract Price.....	77
12. Terms of Payment	77
13. Securities.....	78
14. Taxes and Duties.....	79
D. Intellectual Property	80
15. Copyright	80
16. Software License Agreements	81
17. Confidential Information	83
E. Supply, Installation, Testing, Commissioning, and Acceptance of the System	84
18. Representatives	84
19. Project Plan	86
20. Subcontracting	87
21. Design and Engineering.....	88
22. Procurement, Delivery, and Transport.....	90
23. Product Upgrades.....	93
24. Implementation, Installation, and Other Services.....	94
25. Inspections and Tests	94
26. Installation of the System.....	95
27. Commissioning and Operational Acceptance	96
F. Guarantees and Liabilities.....	100
28. Operational Acceptance Time Guarantee	100
29. Defect Liability	101
30. Functional Guarantees	103
31. Intellectual Property Rights Warranty	104
32. Intellectual Property Rights Indemnity	104
33. Limitation of Liability.....	107

G. Risk Distribution	108
34. Transfer of Ownership	108
35. Care of the System	108
36. Loss of or Damage to Property; Accident or Injury to Workers; Indemnification	109
37. Insurances	111
38. Force Majeure	113
H. Change in Contract Elements	115
39. Changes to the System	115
40. Extension of Time for Achieving Operational Acceptance	118
41. Termination.....	119
42. Assignment	127

General Conditions of Contract

A. CONTRACT AND INTERPRETATION

1. Definitions

1.1 In this Contract, the following terms shall be interpreted as indicated below.

(a) contract elements

- (i) “Contract” means the Contract Agreement entered into between the Purchaser and the Supplier, together with the Contract Documents referred to therein. The Contract Agreement and the Contract Documents shall constitute the Contract, and the term “the Contract” shall in all such documents be construed accordingly.
- (ii) “Contract Documents” means the documents specified in Article 1.1 (Contract Documents) of the Contract Agreement (including any amendments to these Documents).
- (iii) “Contract Agreement” means the agreement entered into between the Purchaser and the Supplier using the form of Contract Agreement contained in the Sample Forms Section of the Bidding Documents and any modifications to this form agreed to by the Purchaser and the Supplier. The date of the Contract Agreement shall be recorded in the signed form.
- (iv) “GCC” means the General Conditions of Contract.
- (v) “SCC” means the Special Conditions of Contract.
- (vi) “Technical Requirements” means the Technical Requirements Section of the Bidding Documents.
- (vii) “Implementation Schedule” means the Implementation Schedule Sub-section of the Technical Requirements.
- viii) “Contract Price” means the price or prices defined in Article 2 (Contract Price and Terms of Payment) of the Contract Agreement.
- (ix) “Procurement Guidelines” refers to the edition **specified in the SCC** of the World Bank

Guidelines: Procurement under IBRD Loans and IDA Credits.

- (x) “Bidding Documents” refers to the collection of documents issued by the Purchaser to instruct and inform potential suppliers of the processes for bidding, selection of the winning bid, and Contract formation, as well as the contractual conditions governing the relationship between the Purchaser and the Supplier. The General and Special Conditions of Contract, the Technical Requirements, and all other documents included in the Bidding Documents reflect the Procurement Guidelines that the Purchaser is obligated to follow during procurement and administration of this Contract.
- (b) entities
 - (i) “Purchaser” means the entity purchasing the Information System, as **specified in the SCC**.
 - (ii) “Project Manager” means the person **named as such in the SCC** or otherwise appointed by the Purchaser in the manner provided in GCC Clause 18.1 (Project Manager) to perform the duties delegated by the Purchaser.
 - (iii) “Supplier” means the firm or Joint Venture whose bid to perform the Contract has been accepted by the Purchaser and is named as such in the Contract Agreement.
 - (iv) “Supplier’s Representative” means any person nominated by the Supplier and named as such in the Contract Agreement or otherwise approved by the Purchaser in the manner provided in GCC Clause 18.2 (Supplier’s Representative) to perform the duties delegated by the Supplier.
 - (v) “Subcontractor” means any firm to whom any of the obligations of the Supplier, including preparation of any design or supply of any Information Technologies or other Goods or Services, is subcontracted directly or indirectly by the Supplier.

- (vi) “Adjudicator” means the person named in Appendix 2 of the Contract Agreement, appointed by agreement between the Purchaser and the Supplier to make a decision on or to settle any dispute between the Purchaser and the Supplier referred to him or her by the parties, pursuant to GCC Clause 6.1 (Adjudication).
 - (vii) “The World Bank” (also called “The Bank”) means the International Bank for Reconstruction and Development (IBRD) or the International Development Association (IDA).
- (c) scope
- (i) “Information System,” also called “the System,” means all the Information Technologies, Materials, and other Goods to be supplied, installed, integrated, and made operational (exclusive of the Supplier’s Equipment), together with the Services to be carried out by the Supplier under the Contract.
 - (ii) “Subsystem” means any subset of the System identified as such in the Contract that may be supplied, installed, tested, and commissioned individually before Commissioning of the entire System.
 - (iii) “Information Technologies” means all information processing and communications-related hardware, Software, supplies, and consumable items that the Supplier is required to supply and install under the Contract.
 - (iv) “Goods” means all equipment, machinery, furnishings, Materials, and other tangible items that the Supplier is required to supply or supply and install under the Contract, including, without limitation, the Information Technologies and Materials, but excluding the Supplier’s Equipment.
 - (v) “Services” means all technical, logistical, management, and any other Services to be provided by the Supplier under the Contract to supply, install, customize, integrate, and make operational the System. Such Services may

include, but are not restricted to, activity management and quality assurance, design, development, customization, documentation, transportation, insurance, inspection, expediting, site preparation, installation, integration, training, data migration, Pre-commissioning, Commissioning, maintenance, and technical support.

- (vi) “The Project Plan” means the document to be developed by the Supplier and approved by the Purchaser, pursuant to GCC Clause 19, based on the requirements of the Contract and the Preliminary Project Plan included in the Supplier’s bid. The “Agreed and Finalized Project Plan” is the version of the Project Plan approved by the Purchaser, in accordance with GCC Clause 19.2. Should the Project Plan conflict with the Contract in any way, the relevant provisions of the Contract, including any amendments, shall prevail.
- (vii) “Software” means that part of the System which are instructions that cause information processing Subsystems to perform in a specific manner or execute specific operations.
- (viii) “System Software” means Software that provides the operating and management instructions for the underlying hardware and other components, and is identified as such in Appendix 4 of the Contract Agreement and such other Software as the parties may agree in writing to be Systems Software. Such System Software includes, but is not restricted to, micro-code embedded in hardware (i.e., “firmware”), operating systems, communications, system and network management, and utility software.
- (ix) “General-Purpose Software” means Software that supports general-purpose office and software development activities and is identified as such in Appendix 4 of the Contract Agreement and such other Software as the parties may agree in writing to be General-Purpose Software. Such General-Purpose Software may include, but is not restricted to,

word processing, spreadsheet, generic database management, and application development software.

- (x) “Application Software” means Software formulated to perform specific business or technical functions and interface with the business or technical users of the System and is identified as such in Appendix 4 of the Contract Agreement and such other Software as the parties may agree in writing to be Application Software.
- (xi) “Standard Software” means Software identified as such in Appendix 4 of the Contract Agreement and such other Software as the parties may agree in writing to be Standard Software.
- (xii) “Custom Software” means Software identified as such in Appendix 4 of the Contract Agreement and such other Software as the parties may agree in writing to be Custom Software.
- (xiii) “Source Code” means the database structures, dictionaries, definitions, program source files, and any other symbolic representations necessary for the compilation, execution, and subsequent maintenance of the Software (typically, but not exclusively, required for Custom Software).
- (xiv) “Materials” means all documentation in printed or printable form and all instructional and informational aides in any form (including audio, video, and text) and on any medium, provided to the Purchaser under the Contract.
- (xv) “Standard Materials” means all Materials not specified as Custom Materials.
- (xvi) “Custom Materials” means Materials developed by the Supplier at the Purchaser’s expense under the Contract and identified as such in Appendix 5 of the Contract Agreement and such other Materials as the parties may agree in writing to be

Custom Materials. Custom Materials includes Materials created from Standard Materials.

- (xvii) “Intellectual Property Rights” means any and all copyright, moral rights, trademark, patent, and other intellectual and proprietary rights, title and interests worldwide, whether vested, contingent, or future, including without limitation all economic rights and all exclusive rights to reproduce, fix, adapt, modify, translate, create derivative works from, extract or re-utilize data from, manufacture, introduce into circulation, publish, distribute, sell, license, sublicense, transfer, rent, lease, transmit or provide access electronically, broadcast, display, enter into computer memory, or otherwise use any portion or copy, in whole or in part, in any form, directly or indirectly, or to authorize or assign others to do so.
 - (xviii) “Supplier’s Equipment” means all equipment, tools, apparatus, or things of every kind required in or for installation, completion and maintenance of the System that are to be provided by the Supplier, but excluding the Information Technologies, or other items forming part of the System.
- (d) activities
- (i) “Delivery” means the transfer of the Goods from the Supplier to the Purchaser in accordance with the current edition Incoterms specified in the Contract.
 - (ii) “Installation” means that the System or a Subsystem as specified in the Contract is ready for Commissioning as provided in GCC Clause 26 (Installation).
 - (iii) “Pre-commissioning” means the testing, checking, and any other required activity that may be specified in the Technical Requirements that are to be carried out by the Supplier in preparation for Commissioning of the System as provided in GCC Clause 26 (Installation).

- (iv) “Commissioning” means operation of the System or any Subsystem by the Supplier following Installation, which operation is to be carried out by the Supplier as provided in GCC Clause 27.1 (Commissioning), for the purpose of carrying out Operational Acceptance Test(s).
 - (v) “Operational Acceptance Tests” means the tests specified in the Technical Requirements and Agreed and Finalized Project Plan to be carried out to ascertain whether the System, or a specified Subsystem, is able to attain the functional and performance requirements specified in the Technical Requirements and Agreed and Finalized Project Plan, in accordance with the provisions of GCC Clause 27.2 (Operational Acceptance Test).
 - (vi) “Operational Acceptance” means the acceptance by the Purchaser of the System (or any Subsystem(s) where the Contract provides for acceptance of the System in parts), in accordance with GCC Clause 27.3 (Operational Acceptance).
- (e) place and time
- (i) “Purchaser’s Country” is the **country named in the SCC**.
 - (ii) “Supplier’s Country” is the country in which the Supplier is legally organized, as named in the Contract Agreement.
 - (iii) “Project Site(s)” means the place(s) **specified in the SCC** for the supply and installation of the System.
 - (iv) “Eligible Country” means the countries and territories eligible for participation in procurements financed by the World Bank as defined in the Procurement Guidelines. (**Note:** The World Bank maintains a list of countries from which Bidders, Goods, and Services are not eligible to participate in procurement financed by the Bank. The list is regularly updated and can be obtained from the Public Information Center of the Bank or its web site on procurement. A copy of the list is contained in the Section of the

Bidding Documents entitled “Eligible Countries for the Provision of Goods, Works, and Services in Bank-Financed Procurement”).

- (v) “Day” means calendar day of the Gregorian Calendar.
- (vi) “Week” means seven (7) consecutive Days, beginning the day of the week as is customary in the Purchaser’s Country.
- (vii) “Month” means calendar month of the Gregorian Calendar.
- (viii) “Year” means twelve (12) consecutive Months.
- (ix) “Effective Date” means the date of fulfillment of all conditions specified in Article 3 (Effective Date for Determining Time for Achieving Operational Acceptance) of the Contract Agreement, for the purpose of determining the Delivery, Installation, and Operational Acceptance dates for the System or Subsystem(s).
- (x) “Contract Period” is the time period during which this Contract governs the relations and obligations of the Purchaser and Supplier in relation to the System, as **specified in the SCC**.
- (xi) “Defect Liability Period” (also referred to as the “Warranty Period”) means the period of validity of the warranties given by the Supplier commencing at date of the Operational Acceptance Certificate of the System or Subsystem(s), during which the Supplier is responsible for defects with respect to the System (or the relevant Subsystem[s]) as provided in GCC Clause 29 (Defect Liability).
- (xii) “The Post-Warranty Services Period” means the number of years **defined in the SCC** (if any), following the expiration of the Warranty Period during which the Supplier may be obligated to provide Software licenses, maintenance, and/or technical support services for the System, either under this Contract or under separate contract(s).
- (xiii) “The Coverage Period” means the Days of the Week and the hours of those Days during which

maintenance, operational, and/or technical support services (if any) must be available.

2. Contract Documents

2.1 Subject to Article 1.2 (Order of Precedence) of the Contract Agreement, all documents forming part of the Contract (and all parts of these documents) are intended to be correlative, complementary, and mutually explanatory. The Contract shall be read as a whole.

3. Interpretation

3.1 Governing Language

3.1.1 All Contract Documents and related correspondence exchanged between Purchaser and Supplier shall be written in the language **specified in the SCC**, and the Contract shall be construed and interpreted in accordance with that language.

3.1.2 If any of the Contract Documents or related correspondence are prepared in a language other than the governing language under GCC Clause 3.1.1 above, the translation of such documents into the governing language shall prevail in matters of interpretation. The originating party, with respect to such documents shall bear the costs and risks of such translation.

3.2 Singular and Plural

The singular shall include the plural and the plural the singular, except where the context otherwise requires.

3.3 Headings

The headings and marginal notes in the GCC are included for ease of reference and shall neither constitute a part of the Contract nor affect its interpretation.

3.4 Persons

Words importing persons or parties shall include firms, corporations, and government entities.

3.5 Incoterms

Unless inconsistent with any provision of the Contract, the meaning of any trade term and the rights and obligations of parties thereunder shall be as prescribed by the current Incoterms (“Incoterms 2000” or a more recent version if and as published). Incoterms are the international rules for interpreting trade terms published by the International

Chamber of Commerce, 38 Cours Albert 1er, 75008 Paris, France.

3.6 Entire Agreement

The Contract constitutes the entire agreement between the Purchaser and Supplier with respect to the subject matter of Contract and supersedes all communications, negotiations, and agreements (whether written or oral) of parties with respect to the subject matter of the Contract made prior to the date of Contract.

3.7 Amendment

No amendment or other variation of the Contract shall be effective unless it is in writing, is dated, expressly refers to the Contract, and is signed by a duly authorized representative of each party to the Contract.

3.8 Independent Supplier

The Supplier shall be an independent contractor performing the Contract. The Contract does not create any agency, partnership, joint venture, or other joint relationship between the parties to the Contract.

Subject to the provisions of the Contract, the Supplier shall be solely responsible for the manner in which the Contract is performed. All employees, representatives, or Subcontractors engaged by the Supplier in connection with the performance of the Contract shall be under the complete control of the Supplier and shall not be deemed to be employees of the Purchaser, and nothing contained in the Contract or in any subcontract awarded by the Supplier shall be construed to create any contractual relationship between any such employees, representatives, or Subcontractors and the Purchaser.

3.9 Joint Venture

If the Supplier is a Joint Venture of two or more firms, all such firms shall be jointly and severally bound to the Purchaser for the fulfillment of the provisions of the Contract and shall designate one of such firms to act as a leader with authority to bind the Joint Venture. The composition or constitution of the Joint Venture shall not be altered without the prior consent of the Purchaser.

3.10 Nonwaiver

3.10.1 Subject to GCC Clause 3.10.2 below, no relaxation, forbearance, delay, or indulgence by either party in enforcing any of the terms and conditions of the Contract or the granting of time by either party to the other shall prejudice, affect, or restrict the rights of that party under the Contract, nor shall any waiver by either party of any breach of Contract operate as waiver of any subsequent or continuing breach of Contract.

3.10.2 Any waiver of a party's rights, powers, or remedies under the Contract must be in writing, must be dated and signed by an authorized representative of the party granting such waiver, and must specify the right and the extent to which it is being waived.

3.11 Severability

If any provision or condition of the Contract is prohibited or rendered invalid or unenforceable, such prohibition, invalidity, or unenforceability shall not affect the validity or enforceability of any other provisions and conditions of the Contract.

3.12 Country of Origin

"Origin" means the place where the Information Technologies, Materials, and other Goods for the System were produced or from which the Services are supplied. Goods are produced when, through manufacturing, processing, Software development, or substantial and major assembly or integration of components, a commercially recognized product results that is substantially different in basic characteristics or in purpose or utility from its components. The Origin of Goods and Services is distinct from the nationality of the Supplier and may be different.

4. Notices

4.1 Unless otherwise stated in the Contract, all notices to be given under the Contract shall be in writing and shall be sent, pursuant to GCC Clause 4.3 below, by personal delivery, airmail post, special courier, cable, telegraph, telex, facsimile, electronic mail, or Electronic Data Interchange (EDI), with the following provisions.

4.1.1 Any notice sent by cable, telegraph, telex, facsimile, electronic mail, or EDI shall be confirmed within two

(2) days after dispatch by notice sent by airmail post or special courier, except as otherwise specified in the Contract.

4.1.2 Any notice sent by airmail post or special courier shall be deemed (in the absence of evidence of earlier receipt) to have been delivered ten (10) days after dispatch. In proving the fact of dispatch, it shall be sufficient to show that the envelope containing such notice was properly addressed, stamped, and conveyed to the postal authorities or courier service for transmission by airmail or special courier.

4.1.3 Any notice delivered personally or sent by cable, telegraph, telex, facsimile, electronic mail, or EDI shall be deemed to have been delivered on the date of its dispatch.

4.1.4 Either party may change its postal, cable, telex, facsimile, electronic mail, or EDI addresses for receipt of such notices by ten (10) days' notice to the other party in writing.

4.2 Notices shall be deemed to include any approvals, consents, instructions, orders, certificates, information and other communication to be given under the Contract.

4.3 Pursuant to GCC Clause 18, notices from/to the Purchaser are normally given by, or addressed to, the Project Manager, while notices from/to the Supplier are normally given by, or addressed to, the Supplier's Representative, or in its absence its deputy if any. If there is no appointed Project Manager or Supplier's Representative (or deputy), or if their related authority is limited by the SCC for GCC Clauses 18.1 or 18.2.2, or for any other reason, the Purchaser or Supplier may give and receive notices at their fallback addresses. The address of the Project Manager and the fallback address of the Purchaser are as **specified in the SCC** or as subsequently established/amended. The address of the Supplier's Representative and the fallback address of the Supplier are as specified in Appendix 1 of the Contract Agreement or as subsequently established/amended.

- | | |
|----------------------------------|--|
| 5. Governing Law | 5.1 The Contract shall be governed by and interpreted in accordance with the laws of the country specified in the SCC. |
| 6. Settlement of Disputes | 6.1 Adjudication |

- 6.1.1 If any dispute of any kind whatsoever shall arise between the Purchaser and the Supplier in connection with or arising out of the Contract, including without prejudice to the generality of the foregoing, any question regarding its existence, validity, or termination, or the operation of the System (whether during the progress of implementation or after its achieving Operational Acceptance and whether before or after the termination, abandonment, or breach of the Contract), the parties shall seek to resolve any such dispute by mutual consultation. If the parties fail to resolve such a dispute by mutual consultation within fourteen (14) days after one party has notified the other in writing of the dispute, then, if the Contract Agreement in Appendix 2 includes and names an Adjudicator, the dispute shall, within another fourteen (14) days, be referred in writing by either party to the Adjudicator, with a copy to the other party. If there is no Adjudicator specified in the Contract Agreement, the mutual consultation period stated above shall last twenty-eight (28) days (instead of fourteen), upon expiry of which either party may move to the notification of arbitration pursuant to GCC Clause 6.2.1.
- 6.1.2 The Adjudicator shall give his or her decision in writing to both parties within twenty-eight (28) days of the dispute being referred to the Adjudicator. If the Adjudicator has done so, and no notice of intention to commence arbitration has been given by either the Purchaser or the Supplier within fifty-six (56) days of such reference, the decision shall become final and binding upon the Purchaser and the Supplier. Any decision that has become final and binding shall be implemented by the parties forthwith.
- 6.1.3 The Adjudicator shall be paid an hourly fee at the rate specified in the Contract Agreement plus reasonable expenditures incurred in the execution of duties as Adjudicator, and these costs shall be divided equally between the Purchaser and the Supplier.
- 6.1.4 Should the Adjudicator resign or die, or should the Purchaser and the Supplier agree that the Adjudicator is not fulfilling his or her functions in accordance with

the provisions of the Contract, a new Adjudicator shall be jointly appointed by the Purchaser and the Supplier.

Failing agreement between the two within twenty-eight (28) days, the new Adjudicator shall be appointed at the request of either party by the Appointing Authority **specified in the SCC**, or, if no Appointing Authority is **specified in SCC**, the Contract shall, from this point onward and until the parties may otherwise agree on an Adjudicator or an Appointing Authority, be implemented as if there is no Adjudicator.

6.2 Arbitration

6.2.1 If

- (a) the Purchaser or the Supplier is dissatisfied with the Adjudicator's decision and acts before this decision has become final and binding pursuant to GCC Clause 6.1.2, or
- (b) the Adjudicator fails to give a decision within the allotted time from referral of the dispute pursuant to GCC Clause 6.1.2, and the Purchaser or the Supplier acts within the following fourteen (14) days, or
- (c) in the absence of an Adjudicator from the Contract Agreement, the mutual consultation pursuant to GCC Clause 6.1.1 expires without resolution of the dispute and the Purchaser or the Supplier acts within the following fourteen (14) days,

then either the Purchaser or the Supplier may act to give notice to the other party, with a copy for information to the Adjudicator in case an Adjudicator had been involved, of its intention to commence arbitration, as provided below, as to the matter in dispute, and no arbitration in respect of this matter may be commenced unless such notice is given.

6.2.2 Any dispute in respect of which a notice of intention to commence arbitration has been given, in accordance with GCC Clause 6.2.1, shall be finally settled by arbitration. Arbitration may be commenced prior to or after Installation of the Information System.

6.2.3 Arbitration proceedings shall be conducted in accordance with the rules of procedure **specified in the SCC**.

6.3 Notwithstanding any reference to the Adjudicator or arbitration in this clause,

- (a) the parties shall continue to perform their respective obligations under the Contract unless they otherwise agree;
- (b) the Purchaser shall pay the Supplier any monies due the Supplier.

B. SUBJECT MATTER OF CONTRACT

7. Scope of the System

7.1 Unless otherwise expressly **limited in the SCC** or Technical Requirements, the Supplier's obligations cover the provision of all Information Technologies, Materials and other Goods as well as the performance of all Services required for the design, development, and implementation (including procurement, quality assurance, assembly, associated site preparation, Delivery, Pre-commissioning, Installation, Testing, and Commissioning) of the System, in accordance with the plans, procedures, specifications, drawings, codes, and any other documents specified in the Contract and the Agreed and Finalized Project Plan.

7.2 The Supplier shall, unless specifically excluded in the Contract, perform all such work and / or supply all such items and Materials not specifically mentioned in the Contract but that can be reasonably inferred from the Contract as being required for attaining Operational Acceptance of the System as if such work and / or items and Materials were expressly mentioned in the Contract.

7.3 The Supplier's obligations (if any) to provide Goods and Services as implied by the Recurrent Cost tables of the Supplier's bid, such as consumables, spare parts, and technical services (e.g., maintenance, technical assistance, and operational support), are as **specified in the SCC**, including the relevant terms, characteristics, and timings.

8. Time for Commencement and Operational Acceptance

8.1 The Supplier shall commence work on the System within the period **specified in the SCC**, and without prejudice to GCC Clause 28.2, the Supplier shall thereafter proceed with the System in accordance with the time schedule specified in the

Implementation Schedule in the Technical Requirements Section and any refinements made in the Agreed and Finalized Project Plan.

8.2 The Supplier shall achieve Operational Acceptance of the System (or Subsystem(s) where a separate time for Operational Acceptance of such Subsystem(s) is specified in the Contract) within the time **specified in the SCC** and in accordance with the time schedule specified in the Implementation Schedule in the Technical Requirements Section and any refinements made in the Agreed and Finalized Project Plan, or within such extended time to which the Supplier shall be entitled under GCC Clause 40 (Extension of Time for Achieving Operational Acceptance).

9. Supplier's Responsibilities

9.1 The Supplier shall conduct all activities with due care and diligence, in accordance with the Contract and with the skill and care expected of a competent provider of information technologies, information systems, support, maintenance, training, and other related services, or in accordance with best industry practices. In particular, the Supplier shall provide and employ only technical personnel who are skilled and experienced in their respective callings and supervisory staff who are competent to adequately supervise the work at hand.

9.2 The Supplier confirms that it has entered into this Contract on the basis of a proper examination of the data relating to the System provided by the Purchaser and on the basis of information that the Supplier could have obtained from a visual inspection of the site (if access to the site was available) and of other data readily available to the Supplier relating to the System as at the date twenty-eight (28) days prior to bid submission. The Supplier acknowledges that any failure to acquaint itself with all such data and information shall not relieve its responsibility for properly estimating the difficulty or cost of successfully performing the Contract.

9.3 The Supplier shall be responsible for timely provision of all resources, information, and decision making under its control that are necessary to reach a mutually Agreed and Finalized Project Plan (pursuant to GCC Clause 19.2) within the time schedule specified in the Implementation Schedule in the Technical Requirements Section. Failure to provide such resources, information, and decision making may constitute grounds for termination pursuant to GCC Clause 41.2.

9.4 The Supplier shall acquire in its name all permits, approvals, and/or licenses from all local, state, or national government

authorities or public service undertakings in the Purchaser's Country that are necessary for the performance of the Contract, including, without limitation, visas for the Supplier's and Subcontractor's personnel and entry permits for all imported Supplier's Equipment. The Supplier shall acquire all other permits, approvals, and/or licenses that are not the responsibility of the Purchaser under GCC Clause 10.4 and that are necessary for the performance of the Contract.

- 9.5 The Supplier shall comply with all laws in force in the Purchaser's Country. The laws will include all national, provincial, municipal, or other laws that affect the performance of the Contract and are binding upon the Supplier. The Supplier shall indemnify and hold harmless the Purchaser from and against any and all liabilities, damages, claims, fines, penalties, and expenses of whatever nature arising or resulting from the violation of such laws by the Supplier or its personnel, including the Subcontractors and their personnel, but without prejudice to GCC Clause 10.1. The Supplier shall not indemnify the Purchaser to the extent that such liability, damage, claims, fines, penalties, and expenses were caused or contributed to by a fault of the Purchaser.
- 9.6 The Supplier shall, in all dealings with its labor and the labor of its Subcontractors currently employed on or connected with the Contract, pay due regard to all recognized festivals, official holidays, religious or other customs, and all local laws and regulations pertaining to the employment of labor.
- 9.7 Any Information Technologies or other Goods and Services that will be incorporated in or be required for the System and other supplies shall have their Origin, as defined in GCC Clause 3.12, in a country that shall be an Eligible Country, as defined in GCC Clause 1.1 (e) (iv).
- 9.8 The Supplier shall permit the Bank and/or persons appointed by the Bank to inspect the Supplier's offices and/or the accounts and records of the Supplier and its sub-contractors relating to the performance of the Contract, and to have such accounts and records audited by auditors appointed by the Bank if required by the Bank. The Supplier's attention is drawn to Sub-Clause 41.2.1(c), which provides, inter alia, that acts intended to materially impede the exercise of the Bank's inspection and audit rights provided for under Sub-Clause 9.8 constitute a prohibited practice subject to contract termination

(as well as to a determination of ineligibility under the Procurement Guidelines)

9.9 Other Supplier responsibilities, if any, are as **stated in the SCC**.

10. Purchaser's Responsibilities

10.1 The Purchaser shall ensure the accuracy of all information and/or data to be supplied by the Purchaser to the Supplier, except when otherwise expressly stated in the Contract.

10.2 The Purchaser shall be responsible for timely provision of all resources, information, and decision making under its control that are necessary to reach an Agreed and Finalized Project Plan (pursuant to GCC Clause 19.2) within the time schedule specified in the Implementation Schedule in the Technical Requirements Section. Failure to provide such resources, information, and decision making may constitute grounds for Termination pursuant to GCC Clause 41.3.1 (b).

10.3 The Purchaser shall be responsible for acquiring and providing legal and physical possession of the site and access to it, and for providing possession of and access to all other areas reasonably required for the proper execution of the Contract.

10.4 If requested by the Supplier, the Purchaser shall use its best endeavors to assist the Supplier in obtaining in a timely and expeditious manner all permits, approvals, and/or licenses necessary for the execution of the Contract from all local, state, or national government authorities or public service undertakings that such authorities or undertakings require the Supplier or Subcontractors or the personnel of the Supplier or Subcontractors, as the case may be, to obtain.

10.5 In such cases where the responsibilities of specifying and acquiring or upgrading telecommunications and/or electric power services falls to the Supplier, as specified in the Technical Requirements, SCC, Agreed and Finalized Project Plan, or other parts of the Contract, the Purchaser shall use its best endeavors to assist the Supplier in obtaining such services in a timely and expeditious manner.

10.6 The Purchaser shall be responsible for timely provision of all resources, access, and information necessary for the Installation and Operational Acceptance of the System (including, but not limited to, any required telecommunications or electric power services), as identified in the Agreed and Finalized Project Plan, except where provision of such items is explicitly identified in the Contract

- as being the responsibility of the Supplier. Delay by the Purchaser may result in an appropriate extension of the Time for Operational Acceptance, at the Supplier's discretion.
- 10.7 Unless otherwise specified in the Contract or agreed upon by the Purchaser and the Supplier, the Purchaser shall provide sufficient, properly qualified operating and technical personnel, as required by the Supplier to properly carry out Delivery, Pre-commissioning, Installation, Commissioning, and Operational Acceptance, at or before the time specified in the Technical Requirements Section's Implementation Schedule and the Agreed and Finalized Project Plan.
- 10.8 The Purchaser will designate appropriate staff for the training courses to be given by the Supplier and shall make all appropriate logistical arrangements for such training as specified in the Technical Requirements, SCC, the Agreed and Finalized Project Plan, or other parts of the Contract.
- 10.9 The Purchaser assumes primary responsibility for the Operational Acceptance Test(s) for the System, in accordance with GCC Clause 27.2, and shall be responsible for the continued operation of the System after Operational Acceptance. However, this shall not limit in any way the Supplier's responsibilities after the date of Operational Acceptance otherwise specified in the Contract.
- 10.10 The Purchaser is responsible for performing and safely storing timely and regular backups of its data and Software in accordance with accepted data management principles, except where such responsibility is clearly assigned to the Supplier elsewhere in the Contract.
- 10.11 All costs and expenses involved in the performance of the obligations under this GCC Clause 10 shall be the responsibility of the Purchaser, save those to be incurred by the Supplier with respect to the performance of the Operational Acceptance Test(s), in accordance with GCC Clause 27.2.
- 10.12 Other Purchaser responsibilities, if any, are **as stated in the SCC**.

C. PAYMENT

11. Contract Price

- 11.1 The Contract Price shall be as specified in Article 2 (Contract Price and Terms of Payment) of the Contract Agreement.
- 11.2 The Contract Price shall be a firm lump sum not subject to any alteration, except:
- (a) in the event of a Change in the System pursuant to GCC Clause 39 or to other clauses in the Contract;
 - (b) in accordance with the price adjustment formula (if any) **specified in the SCC.**
- 11.3 The Supplier shall be deemed to have satisfied itself as to the correctness and sufficiency of the Contract Price, which shall, except as otherwise provided for in the Contract, cover all its obligations under the Contract.

12. Terms of Payment

- 12.1 The Supplier's request for payment shall be made to the Purchaser in writing, accompanied by an invoice describing, as appropriate, the System or Subsystem(s), Delivered, Pre-commissioned, Installed, and Operationally Accepted, and by documents submitted pursuant to GCC Clause 22.5 and upon fulfillment of other obligations stipulated in the Contract.
- The Contract Price shall be paid as **specified in the SCC.**
- 12.2 No payment made by the Purchaser herein shall be deemed to constitute acceptance by the Purchaser of the System or any Subsystem(s).
- 12.3 Payments shall be made promptly by the Purchaser, but in no case later than forty five (45) days after submission of a valid invoice by the Supplier. In the event that the Purchaser fails to make any payment by its respective due date or within the period set forth in the Contract, the Purchaser shall pay to the Supplier interest on the amount of such delayed payment at the rate(s) **specified in the SCC** for the period of delay until payment has been made in full, whether before or after judgment or arbitration award.
- 12.4 All payments shall be made in the currency(ies) specified in the Contract Agreement, pursuant to GCC Clause 11. For Goods and Services supplied locally, payments shall be made in the currency of the Purchaser's Country, unless otherwise **specified in the SCC.**

12.5 Unless otherwise **specified in the SCC**, payment of the foreign currency portion of the Contract Price for Goods supplied from outside the Purchaser's Country shall be made to the Supplier through an irrevocable letter of credit opened by an authorized bank in the Supplier's Country and will be payable on presentation of the appropriate documents. It is agreed that the letter of credit will be subject to Article 10 of the latest revision of Uniform Customs and Practice for Documentary Credits, published by the International Chamber of Commerce, Paris.

13. Securities

13.1 Issuance of Securities

The Supplier shall provide the securities specified below in favor of the Purchaser at the times and in the amount, manner, and form specified below.

13.2 Advance Payment Security

13.2.1 As **specified in the SCC**, the Supplier shall provide a security equal in amount and currency to the advance payment, and valid until the System is Operationally Accepted.

13.2.2 The security shall be in the form provided in the Bidding Documents or in another form acceptable to the Purchaser. The amount of the security shall be reduced in proportion to the value of the System executed by and paid to the Supplier from time to time and shall automatically become null and void when the full amount of the advance payment has been recovered by the Purchaser. The way the value of the security is deemed to become reduced and, eventually, voided is as **specified in the SCC**. The security shall be returned to the Supplier immediately after its expiration.

13.3 Performance Security

13.3.1 The Supplier shall, within twenty-eight (28) days of the notification of Contract award, provide a security for the due performance of the Contract in the amount and currency **specified in the SCC**.

13.3.2 The security shall be a bank guarantee in the form provided in the Sample Forms Section of the Bidding Documents, or it shall be in another form acceptable to the Purchaser.

13.3.3 The security shall automatically become null and void once all the obligations of the Supplier under the Contract have been fulfilled, including, but not limited to, any obligations during the Warranty Period and any extensions to the period. The security shall be returned to the Supplier no later than twenty-eight (28) days after its expiration.

13.3.4 Upon Operational Acceptance of the entire System, the security shall be reduced to the amount **specified in the SCC**, on the date of such Operational Acceptance, so that the reduced security would only cover the remaining warranty obligations of the Supplier.

14. Taxes and Duties

14.1 For Goods or Services supplied from outside the Purchaser's country, the Supplier shall be entirely responsible for all taxes, stamp duties, license fees, and other such levies imposed outside the Purchaser's country. Any duties, such as importation or customs duties, and taxes and other levies, payable in the Purchaser's country for the supply of Goods and Services from outside the Purchaser's country are the responsibility of the Purchaser unless these duties or taxes have been made part of the Contract Price in Article 2 of the Contract Agreement and the Price Schedule it refers to, in which case the duties and taxes will be the Supplier's responsibility.

14.2 For Goods or Services supplied locally, the Supplier shall be entirely responsible for all taxes, duties, license fees, etc., incurred until delivery of the contracted Goods or Services to the Purchaser. The only exception are taxes or duties, such as value-added or sales tax or stamp duty as apply to, or are clearly identifiable, on the invoices and provided they apply in the Purchaser's country, and only if these taxes, levies and/or duties are also excluded from the Contract Price in Article 2 of the Contract Agreement and the Price Schedule it refers to.

14.3 If any tax exemptions, reductions, allowances, or privileges may be available to the Supplier in the Purchaser's Country, the Purchaser shall use its best efforts to enable the Supplier to benefit from any such tax savings to the maximum allowable extent.

14.4 For the purpose of the Contract, it is agreed that the Contract Price specified in Article 2 (Contract Price and Terms of Payment) of the Contract Agreement is based on the taxes, duties, levies, and charges prevailing at the date twenty-eight

(28) days prior to the date of bid submission in the Purchaser's Country (also called "Tax" in this GCC Clause 14.4). If any Tax rates are increased or decreased, a new Tax is introduced, an existing Tax is abolished, or any change in interpretation or application of any Tax occurs in the course of the performance of the Contract, which was or will be assessed on the Supplier, its Subcontractors, or their employees in connection with performance of the Contract, an equitable adjustment to the Contract Price shall be made to fully take into account any such change by addition to or reduction from the Contract Price, as the case may be.

D. INTELLECTUAL PROPERTY

15. Copyright

- 15.1 The Intellectual Property Rights in all Standard Software and Standard Materials shall remain vested in the owner of such rights.
- 15.2 The Purchaser agrees to restrict use, copying, or duplication of the Standard Software and Standard Materials in accordance with GCC Clause 16, except that additional copies of Standard Materials may be made by the Purchaser for use within the scope of the project of which the System is a part, in the event that the Supplier does not deliver copies within thirty (30) days from receipt of a request for such Standard Materials.
- 15.3 The Purchaser's contractual rights to use the Standard Software or elements of the Standard Software may not be assigned, licensed, or otherwise transferred voluntarily except in accordance with the relevant license agreement or as may be otherwise **specified in the SCC**.
- 15.4 As applicable, the Purchaser's and Supplier's rights and obligations with respect to Custom Software or elements of the Custom Software, including any license agreements, and with respect to Custom Materials or elements of the Custom Materials, are specified in the SCC. **Subject to the SCC**, the Intellectual Property Rights in all Custom Software and Custom Materials specified in Appendices 4 and 5 of the Contract Agreement (if any) shall, at the date of this Contract or on creation of the rights (if later than the date of this Contract), vest in the Purchaser. The Supplier shall do and execute or arrange for the doing and executing of each necessary act, document, and thing that the Purchaser may consider necessary or desirable to perfect the right, title, and

interest of the Purchaser in and to those rights. In respect of such Custom Software and Custom Materials, the Supplier shall ensure that the holder of a moral right in such an item does not assert it, and the Supplier shall, if requested to do so by the Purchaser and where permitted by applicable law, ensure that the holder of such a moral right waives it.

15.5 The parties shall enter into such (if any) escrow arrangements in relation to the Source Code to some or all of the Software as are **specified in the SCC** and in **accordance with the SCC**.

16. Software License Agreements

16.1 Except to the extent that the Intellectual Property Rights in the Software vest in the Purchaser, the Supplier hereby grants to the Purchaser license to access and use the Software, including all inventions, designs, and Remark embodied in the Software.

Such license to access and use the Software shall:

- (a) be:
 - (i) nonexclusive;
 - (ii) fully paid up and irrevocable (except that it shall terminate if the Contract terminates under GCC Clauses 41.1 or 41.3);
 - (iii) valid throughout the territory of the Purchaser's Country (or such other territory as **specified in the SCC**); and
 - (iv) subject to additional restrictions (if any) as **specified in the SCC**.
- (b) permit the Software to be:
 - (i) used or copied for use on or with the computer(s) for which it was acquired (if specified in the Technical Requirements and/or the Supplier's bid), plus a backup computer(s) of the same or similar capacity, if the primary is(are) inoperative, and during a reasonable transitional period when use is being transferred between primary and backup;
 - (ii) as **specified in the SCC**, used or copied for use on or transferred to a replacement computer(s), (and use on the original and replacement computer(s) may be simultaneous during a reasonable transitional period) provided that, if the Technical

Requirements and/or the Supplier's bid specifies a class of computer to which the license is restricted and unless the Supplier agrees otherwise in writing, the replacement computer(s) is(are) within that class;

- (iii) if the nature of the System is such as to permit such access, accessed from other computers connected to the primary and/or backup computer(s) by means of a local or wide-area network or similar arrangement, and used on or copied for use on those other computers to the extent necessary to that access;
- (iv) reproduced for safekeeping or backup purposes;
- (v) customized, adapted, or combined with other computer software for use by the Purchaser, provided that derivative software incorporating any substantial part of the delivered, restricted Software shall be subject to same restrictions as are set forth in this Contract;
- (vi) as **specified in the SCC**, disclosed to, and reproduced for use by, support service suppliers and their subcontractors, (and the Purchaser may sublicense such persons to use and copy for use the Software) to the extent reasonably necessary to the performance of their support service contracts, subject to the same restrictions as are set forth in this Contract; and
- (vii) disclosed to, and reproduced for use by, the Purchaser and by such other persons as are **specified in the SCC** (and the Purchaser may sublicense such persons to use and copy for use the Software), subject to the same restrictions as are set forth in this Contract.

16.2 The Standard Software may be subject to audit by the Supplier, in accordance with the terms **specified in the SCC**, to verify compliance with the above license agreements.

17. Confidential Information

17.1 Except if otherwise **specified in the SCC**, the "Receiving Party" (either the Purchaser or the Supplier) shall keep confidential and shall not, without the written consent of the other party to this Contract ("the Disclosing Party"), divulge to any third party any documents, data, or other information of a confidential nature ("Confidential Information") connected with this Contract, and furnished directly or indirectly by the Disclosing Party prior to or during performance, or following termination, of this Contract.

17.2 For the purposes of GCC Clause 17.1, the Supplier is also deemed to be the Receiving Party of Confidential Information generated by the Supplier itself in the course of the performance of its obligations under the Contract and relating to the businesses, finances, suppliers, employees, or other contacts of the Purchaser or the Purchaser's use of the System.

17.3 Notwithstanding GCC Clauses 17.1 and 17.2:

- (a) the Supplier may furnish to its Subcontractor Confidential Information of the Purchaser to the extent reasonably required for the Subcontractor to perform its work under the Contract; and
- (b) the Purchaser may furnish Confidential Information of the Supplier: (i) to its support service suppliers and their subcontractors to the extent reasonably required for them to perform their work under their support service contracts; and (ii) to its affiliates and subsidiaries,

in which event the Receiving Party shall ensure that the person to whom it furnishes Confidential Information of the Disclosing Party is aware of and abides by the Receiving Party's obligations under this GCC Clause 17 as if that person were party to the Contract in place of the Receiving Party.

17.4 The Purchaser shall not, without the Supplier's prior written consent, use any Confidential Information received from the Supplier for any purpose other than the operation, maintenance and further development of the System. Similarly, the Supplier shall not, without the Purchaser's prior written consent, use any Confidential Information received from the Purchaser for any purpose other than those that are required for the performance of the Contract.

- 17.5 The obligation of a party under GCC Clauses 17.1 through 17.4 above, however, shall not apply to that information which:
- (a) now or hereafter enters the public domain through no fault of the Receiving Party;
 - (b) can be proven to have been possessed by the Receiving Party at the time of disclosure and that was not previously obtained, directly or indirectly, from the Disclosing Party;
 - (c) otherwise lawfully becomes available to the Receiving Party from a third party that has no obligation of confidentiality.
- 17.6 The above provisions of this GCC Clause 17 shall not in any way modify any undertaking of confidentiality given by either of the parties to this Contract prior to the date of the Contract in respect of the System or any part thereof.
- 17.7 The provisions of this GCC Clause 17 shall survive the termination, for whatever reason, of the Contract for three (3) years or such longer period as may be **specified in the SCC**.

E. SUPPLY, INSTALLATION, TESTING, COMMISSIONING, AND ACCEPTANCE OF THE SYSTEM

18. Representatives 18.1 Project Manager

If the Project Manager is not named in the Contract, then within fourteen (14) days of the Effective Date, the Purchaser shall appoint and notify the Supplier in writing of the name of the Project Manager. The Purchaser may from time to time appoint some other person as the Project Manager in place of the person previously so appointed and shall give a notice of the name of such other person to the Supplier without delay. No such appointment shall be made at such a time or in such a manner as to impede the progress of work on the System. Such appointment shall take effect only upon receipt of such notice by the Supplier. Subject to the extensions and/or limitations **specified in the SCC** (if any), the Project Manager shall have the authority to represent the Purchaser on all day-to-day matters relating to the System or arising from the Contract, and shall normally be the person giving or receiving notices on behalf of the Purchaser pursuant to GCC Clause 4.

18.2 Supplier's Representative

18.2.1 If the Supplier's Representative is not named in the Contract, then within fourteen (14) days of the Effective Date, the Supplier shall appoint the Supplier's Representative and shall request the Purchaser in writing to approve the person so appointed. The request must be accompanied by a detailed curriculum vitae for the nominee, as well as a description of any other System or non-System responsibilities the nominee would retain while performing the duties of the Supplier's Representative. If the Purchaser does not object to the appointment within fourteen (14) days, the Supplier's Representative shall be deemed to have been approved. If the Purchaser objects to the appointment within fourteen (14) days giving the reason therefor, then the Supplier shall appoint a replacement within fourteen (14) days of such objection in accordance with this GCC Clause 18.2.1.

18.2.2 Subject to the extensions and/or limitations **specified in the SCC** (if any), the Supplier's Representative shall have the authority to represent the Supplier on all day-to-day matters relating to the System or arising from the Contract, and shall normally be the person giving or receiving notices on behalf of the Supplier pursuant to GCC Clause 4.

18.2.3 The Supplier shall not revoke the appointment of the Supplier's Representative without the Purchaser's prior written consent, which shall not be unreasonably withheld. If the Purchaser consents to such an action, the Supplier shall appoint another person of equal or superior qualifications as the Supplier's Representative, pursuant to the procedure set out in GCC Clause 18.2.1.

18.2.4 The Supplier's Representative and staff are obliged to work closely with the Purchaser's Project Manager and staff, act within their own authority, and abide by directives issued by the Purchaser that are consistent with the terms of the Contract. The Supplier's Representative is responsible for managing the activities of its personnel and any subcontracted personnel.

18.2.5 The Supplier's Representative may, subject to the approval of the Purchaser (which shall not be

unreasonably withheld), at any time delegate to any person any of the powers, functions, and authorities vested in him or her. Any such delegation may be revoked at any time. Any such delegation or revocation shall be subject to a prior notice signed by the Supplier's Representative and shall specify the powers, functions, and authorities thereby delegated or revoked. No such delegation or revocation shall take effect unless and until the notice of it has been delivered.

18.2.6 Any act or exercise by any person of powers, functions and authorities so delegated to him or her in accordance with GCC Clause 18.2.5 shall be deemed to be an act or exercise by the Supplier's Representative.

18.3 Objections and Removals

18.3.1 The Purchaser may by notice to the Supplier object to any representative or person employed by the Supplier in the execution of the Contract who, in the reasonable opinion of the Purchaser, may have behaved inappropriately, be incompetent, or be negligent. The Purchaser shall provide evidence of the same, whereupon the Supplier shall remove such person from work on the System.

18.3.2 If any representative or person employed by the Supplier is removed in accordance with GCC Clause 18.3.1, the Supplier shall, where required, promptly appoint a replacement.

19. Project Plan

19.1 In close cooperation with the Purchaser and based on the Preliminary Project Plan included in the Supplier's bid, the Supplier shall develop a Project Plan encompassing the activities specified in the Contract. The contents of the Project Plan shall be as **specified in the SCC** and/or Technical Requirements.

19.2 The Supplier shall formally present to the Purchaser the Project Plan in accordance with the procedure specified in the SCC.

19.3 If required, the impact on the Implementation Schedule of modifications agreed during finalization of the Agreed and Finalized Project Plan shall be incorporated in the Contract by amendment, in accordance with GCC Clauses 39 and 40.

19.4 The Supplier shall undertake to supply, install, test, and commission the System in accordance with the Agreed and Finalized Project Plan and the Contract.

19.5 The Progress and other reports **specified in the SCC** shall be prepared by the Supplier and submitted to the Purchaser in the format and frequency specified in the Technical Requirements.

20. Subcontracting

20.1 Appendix 3 (List of Approved Subcontractors) to the Contract Agreement specifies critical items of supply or services and a list of Subcontractors for each item that are considered acceptable by the Purchaser. If no Subcontractors are listed for an item, the Supplier shall prepare a list of Subcontractors it considers qualified and wishes to be added to the list for such items. The Supplier may from time to time propose additions to or deletions from any such list. The Supplier shall submit any such list or any modification to the list to the Purchaser for its approval in sufficient time so as not to impede the progress of work on the System. The Purchaser shall not withhold such approval unreasonably. Such approval by the Purchaser of a Subcontractor(s) shall not relieve the Supplier from any of its obligations, duties, or responsibilities under the Contract.

20.2 The Supplier may, at its discretion, select and employ Subcontractors for such critical items from those Subcontractors listed pursuant to GCC Clause 20.1. If the Supplier wishes to employ a Subcontractor not so listed, or subcontract an item not so listed, it must seek the Purchaser's prior approval under GCC Clause 20.3.

20.3 For items for which pre-approved Subcontractor lists have not been specified in Appendix 3 to the Contract Agreement, the Supplier may employ such Subcontractors as it may select, provided: (i) the Supplier notifies the Purchaser in writing at least twenty-eight (28) days prior to the proposed mobilization date for such Subcontractor; and (ii) by the end of this period either the Purchaser has granted its approval in writing or fails to respond. The Supplier shall not engage any Subcontractor to which the Purchaser has objected in writing prior to the end of the notice period. The absence of a written objection by the Purchaser during the above specified period shall constitute formal acceptance of the proposed Subcontractor. Except to the extent that it permits the deemed approval of the Purchaser of Subcontractors not listed in the Contract Agreement, nothing in this Clause, however, shall limit the rights and

obligations of either the Purchaser or Supplier as they are specified in GCC Clauses 20.1 and 20.2, in the SCC, or in Appendix 3 of the Contract Agreement.

21. Design and Engineering

21.1 Technical Specifications and Drawings

21.1.1 The Supplier shall execute the basic and detailed design and the implementation activities necessary for successful installation of the System in compliance with the provisions of the Contract or, where not so specified, in accordance with good industry practice.

The Supplier shall be responsible for any discrepancies, errors or omissions in the specifications, drawings, and other technical documents that it has prepared, whether such specifications, drawings, and other documents have been approved by the Project Manager or not, provided that such discrepancies, errors, or omissions are not because of inaccurate information furnished in writing to the Supplier by or on behalf of the Purchaser.

21.1.2 The Supplier shall be entitled to disclaim responsibility for any design, data, drawing, specification, or other document, or any modification of such design, drawings, specification, or other documents provided or designated by or on behalf of the Purchaser, by giving a notice of such disclaimer to the Project Manager.

21.2 Codes and Standards

Wherever references are made in the Contract to codes and standards in accordance with which the Contract shall be executed, the edition or the revised version of such codes and standards current at the date twenty-eight (28) days prior to date of bid submission shall apply unless otherwise **specified in the SCC**. During Contract execution, any changes in such codes and standards shall be applied after approval by the Purchaser and shall be treated in accordance with GCC Clause 39.3.

21.3 Approval/Review of Technical Documents by the Project Manager

21.3.1 The Supplier shall prepare and furnish to the Project Manager the documents as **specified in the SCC** for the Project Manager's approval or review.

Any part of the System covered by or related to the documents to be approved by the Project Manager shall be executed only after the Project Manager's approval of these documents.

GCC Clauses 21.3.2 through 21.3.7 shall apply to those documents requiring the Project Manager's approval, but not to those furnished to the Project Manager for its review only.

- 21.3.2 Within fourteen (14) days after receipt by the Project Manager of any document requiring the Project Manager's approval in accordance with GCC Clause 21.3.1, the Project Manager shall either return one copy of the document to the Supplier with its approval endorsed on the document or shall notify the Supplier in writing of its disapproval of the document and the reasons for disapproval and the modifications that the Project Manager proposes. If the Project Manager fails to take such action within the fourteen (14) days, then the document shall be deemed to have been approved by the Project Manager.
- 21.3.3 The Project Manager shall not disapprove any document except on the grounds that the document does not comply with some specified provision of the Contract or that it is contrary to good industry practice.
- 21.3.4 If the Project Manager disapproves the document, the Supplier shall modify the document and resubmit it for the Project Manager's approval in accordance with GCC Clause 21.3.2. If the Project Manager approves the document subject to modification(s), the Supplier shall make the required modification(s), and the document shall then be deemed to have been approved, subject to GCC Clause 21.3.5. The procedure set out in GCC Clauses 21.3.2 through 21.3.4 shall be repeated, as appropriate, until the Project Manager approves such documents.
- 21.3.5 If any dispute occurs between the Purchaser and the Supplier in connection with or arising out of the disapproval by the Project Manager of any document and/or any modification(s) to a document that cannot be settled between the parties within a reasonable period, then, in case the Contract Agreement includes and names an Adjudicator, such dispute may be referred to the Adjudicator for determination in

accordance with GCC Clause 6.1 (Adjudicator). If such dispute is referred to an Adjudicator, the Project Manager shall give instructions as to whether and if so, how, performance of the Contract is to proceed. The Supplier shall proceed with the Contract in accordance with the Project Manager's instructions, provided that if the Adjudicator upholds the Supplier's view on the dispute and if the Purchaser has not given notice under GCC Clause 6.1.2, then the Supplier shall be reimbursed by the Purchaser for any additional costs incurred by reason of such instructions and shall be relieved of such responsibility or liability in connection with the dispute and the execution of the instructions as the Adjudicator shall decide, and the Time for Achieving Operational Acceptance shall be extended accordingly.

21.3.6 The Project Manager's approval, with or without modification of the document furnished by the Supplier, shall not relieve the Supplier of any responsibility or liability imposed upon it by any provisions of the Contract except to the extent that any subsequent failure results from modifications required by the Project Manager or inaccurate information furnished in writing to the Supplier by or on behalf of the Purchaser.

21.3.7 The Supplier shall not depart from any approved document unless the Supplier has first submitted to the Project Manager an amended document and obtained the Project Manager's approval of the document, pursuant to the provisions of this GCC Clause 21.3. If the Project Manager requests any change in any already approved document and/or in any document based on such an approved document, the provisions of GCC Clause 39 (Changes to the System) shall apply to such request.

22. Procurement, Delivery, and Transport

22.1 Subject to related Purchaser's responsibilities pursuant to GCC Clauses 10 and 14, the Supplier shall manufacture or procure and transport all the Information Technologies, Materials, and other Goods in an expeditious and orderly manner to the Project Site.

22.2 Delivery of the Information Technologies, Materials, and other Goods shall be made by the Supplier in accordance with the Technical Requirements.

22.3 Early or partial deliveries require the explicit written consent of the Purchaser, which consent shall not be unreasonably withheld.

22.4 Transportation

22.4.1 The Supplier shall provide such packing of the Goods as is required to prevent their damage or deterioration during shipment. The packing, marking, and documentation within and outside the packages shall comply strictly with the Purchaser's instructions to the Supplier.

22.4.2 The Supplier will bear responsibility for and cost of transport to the Project Sites in accordance with the terms and conditions used in the specification of prices in the Price Schedules, including the terms and conditions of the associated Incoterms.

22.4.3 Unless otherwise **specified in the SCC**, the Supplier shall be free to use transportation through carriers registered in any eligible country and to obtain insurance from any eligible source country.

22.5 Unless otherwise **specified in the SCC**, the Supplier will provide the Purchaser with shipping and other documents, as specified below:

22.5.1 For Goods supplied from outside the Purchaser's Country:

Upon shipment, the Supplier shall notify the Purchaser and the insurance company contracted by the Supplier to provide cargo insurance by telex, cable, facsimile, electronic mail, or EDI with the full details of the shipment. The Supplier shall promptly send the following documents to the Purchaser by mail or courier, as appropriate, with a copy to the cargo insurance company:

- (a) two copies of the Supplier's invoice showing the description of the Goods, quantity, unit price, and total amount;
- (b) usual transportation documents;
- (c) insurance certificate;
- (d) certificate(s) of origin; and

- (e) estimated time and point of arrival in the Purchaser's Country and at the site.

22.5.2 For Goods supplied locally (i.e., from within the Purchaser's country):

Upon shipment, the Supplier shall notify the Purchaser by telex, cable, facsimile, electronic mail, or EDI with the full details of the shipment. The Supplier shall promptly send the following documents to the Purchaser by mail or courier, as appropriate:

- (a) two copies of the Supplier's invoice showing the Goods' description, quantity, unit price, and total amount;
- (b) delivery note, railway receipt, or truck receipt;
- (c) certificate of insurance;
- (d) certificate(s) of origin; and
- (e) estimated time of arrival at the site.

22.6 Customs Clearance

- (a) The Purchaser will bear responsibility for, and cost of, customs clearance into the Purchaser's country in accordance the particular Incoterm(s) used for Goods supplied from outside the Purchaser's country in the Price Schedules referred to by Article 2 of the Contract Agreement.
- (b) At the request of the Purchaser, the Supplier will make available a representative or agent during the process of customs clearance in the Purchaser's country for goods supplied from outside the Purchaser's country. In the event of delays in customs clearance that are not the fault of the Supplier:
 - (i) the Supplier shall be entitled to an extension in the Time for Achieving Operational Acceptance, pursuant to GCC Clause 40;
 - (ii) the Contract Price shall be adjusted to compensate the Supplier for any additional storage charges that the Supplier may incur as a result of the delay.

23. Product Upgrades

- 23.1 At any point during performance of the Contract, should technological advances be introduced by the Supplier for Information Technologies originally offered by the Supplier in its bid and still to be delivered, the Supplier shall be obligated to offer to the Purchaser the latest versions of the available Information Technologies having equal or better performance or functionality at the same or lesser unit prices, pursuant to GCC Clause 39 (Changes to the System).
- 23.2 At any point during performance of the Contract, for Information Technologies still to be delivered, the Supplier will also pass on to the Purchaser any cost reductions and additional and/or improved support and facilities that it offers to other clients of the Supplier in the Purchaser's Country, pursuant to GCC Clause 39 (Changes to the System).
- 23.3 During performance of the Contract, the Supplier shall offer to the Purchaser all new versions, releases, and updates of Standard Software, as well as related documentation and technical support services, within thirty (30) days of their availability from the Supplier to other clients of the Supplier in the Purchaser's Country, and no later than twelve (12) months after they are released in the country of origin. In no case will the prices for these Software exceed those quoted by the Supplier in the Recurrent Costs tables in its bid.
- 23.4 During the Warranty Period, unless otherwise **specified in the SCC**, the Supplier will provide at no additional cost to the Purchaser all new versions, releases, and updates for all Standard Software that are used in the System, within thirty (30) days of their availability from the Supplier to other clients of the Supplier in the Purchaser's country, and no later than twelve (12) months after they are released in the country of origin of the Software.
- 23.5 The Purchaser shall introduce all new versions, releases or updates of the Software within eighteen (18) months of receipt of a production-ready copy of the new version, release, or update, provided that the new version, release, or update does not adversely affect System operation or performance or require extensive reworking of the System. In cases where the new version, release, or update adversely affects System operation or performance, or requires extensive reworking of the System, the Supplier shall continue to support and maintain the version or release previously in operation for as long as necessary to allow introduction of the new version, release, or update. In no case shall the Supplier stop

supporting or maintaining a version or release of the Software less than twenty four (24) months after the Purchaser receives a production-ready copy of a subsequent version, release, or update. The Purchaser shall use all reasonable endeavors to implement any new version, release, or update as soon as practicable, subject to the twenty-four-month-long stop date.

24. Implementation, Installation, and Other Services

- 24.1 The Supplier shall provide all Services specified in the Contract and Agreed and Finalized Project Plan in accordance with the highest standards of professional competence and integrity.
- 24.2 Prices charged by the Supplier for Services, if not included in the Contract, shall be agreed upon in advance by the parties (including, but not restricted to, any prices submitted by the Supplier in the Recurrent Cost Schedules of its Bid) and shall not exceed the prevailing rates charged by the Supplier to other purchasers in the Purchaser's Country for similar services.

25. Inspections and Tests

- 25.1 The Purchaser or its representative shall have the right to inspect and/or test any components of the System, as specified in the Technical Requirements, to confirm their good working order and/or conformity to the Contract at the point of delivery and/or at the Project Site.
- 25.2 The Purchaser or its representative shall be entitled to attend any such inspections and/or tests of the components, provided that the Purchaser shall bear all costs and expenses incurred in connection with such attendance, including but not limited to all inspection agent fees, travel, and related expenses.
- 25.3 Should the inspected or tested components fail to conform to the Contract, the Purchaser may reject the component(s), and the Supplier shall either replace the rejected component(s), or make alterations as necessary so that it meets the Contract requirements free of cost to the Purchaser.
- 25.4 The Project Manager may require the Supplier to carry out any inspection and/or test not specified in the Contract, provided that the Supplier's reasonable costs and expenses incurred in the carrying out of such inspection and/or test shall be added to the Contract Price. Further, if such inspection and/or test impedes the progress of work on the System and/or the Supplier's performance of its other obligations under the Contract, due allowance will be made in respect of the Time

for Achieving Operational Acceptance and the other obligations so affected.

25.5 If any dispute shall arise between the parties in connection with or caused by an inspection and/or with regard to any component to be incorporated in the System that cannot be settled amicably between the parties within a reasonable period of time, either party may invoke the process pursuant to GCC Clause 6 (Settlement of Disputes), starting with referral of the matter to the Adjudicator in case an Adjudicator is included and named in the Contract Agreement.

26. Installation of the System

26.1 As soon as the System, or any Subsystem, has, in the opinion of the Supplier, been delivered, Pre-commissioned, and made ready for Commissioning and Operational Acceptance Testing in accordance with the Technical Requirements, the SCC and the Agreed and Finalized Project Plan, the Supplier shall so notify the Purchaser in writing.

26.2 The Project Manager shall, within fourteen (14) days after receipt of the Supplier's notice under GCC Clause 26.1, either issue an Installation Certificate in the form specified in the Sample Forms Section in the Bidding Documents, stating that the System, or major component or Subsystem (if Acceptance by major component or Subsystem is specified pursuant to the SCC for GCC Clause 27.2.1), has achieved Installation by the date of the Supplier's notice under GCC Clause 26.1, or notify the Supplier in writing of any defects and/or deficiencies, including, but not limited to, defects or deficiencies in the interoperability or integration of the various components and/or Subsystems making up the System. The Supplier shall use all reasonable endeavors to promptly remedy any defect and/or deficiencies that the Project Manager has notified the Supplier of. The Supplier shall then promptly carry out retesting of the System or Subsystem and, when in the Supplier's opinion the System or Subsystem is ready for Commissioning and Operational Acceptance Testing, notify the Purchaser in writing, in accordance with GCC Clause 26.1. The procedure set out in this GCC Clause 26.2 shall be repeated, as necessary, until an Installation Certificate is issued.

26.3 If the Project Manager fails to issue the Installation Certificate and fails to inform the Supplier of any defects and/or deficiencies within fourteen (14) days after receipt of the Supplier's notice under GCC Clause 26.1, or if the Purchaser puts the System or a Subsystem into production operation,

then the System (or Subsystem) shall be deemed to have achieved successful Installation as of the date of the Supplier's notice or repeated notice, or when the Purchaser put the System into production operation, as the case may be.

27. Commissioning and Operational Acceptance

27.1 Commissioning

27.1.1 Commissioning of the System (or Subsystem if specified pursuant to the SCC for GCC Clause 27.2.1) shall be commenced by the Supplier:

- (a) immediately after the Installation Certificate is issued by the Project Manager, pursuant to GCC Clause 26.2; or
- (b) as otherwise specified in the Technical Requirement or the Agreed and Finalized Project Plan; or
- (c) immediately after Installation is deemed to have occurred, under GCC Clause 26.3.

27.1.2 The Purchaser shall supply the operating and technical personnel and all materials and information reasonably required to enable the Supplier to carry out its obligations with respect to Commissioning.

Production use of the System or Subsystem(s) shall not commence prior to the start of formal Operational Acceptance Testing.

27.2 Operational Acceptance Tests

27.2.1 The Operational Acceptance Tests (and repeats of such tests) shall be the primary responsibility of the Purchaser (in accordance with GCC Clause 10.9), but shall be conducted with the full cooperation of the Supplier during Commissioning of the System (or major components or Subsystem[s] if **specified in the SCC** and supported by the Technical Requirements), to ascertain whether the System (or major component or Subsystem[s]) conforms to the Technical Requirements and meets the standard of performance quoted in the Supplier's bid, including, but not restricted to, the functional and technical performance requirements. The Operational Acceptance Tests during Commissioning will be conducted as **specified in the**

SCC, the Technical Requirements and/or the Agreed and Finalized Project Plan.

At the Purchaser's discretion, Operational Acceptance Tests may also be performed on replacement Goods, upgrades and new version releases, and Goods that are added or field-modified after Operational Acceptance of the System.

27.2.2 If for reasons attributable to the Purchaser, the Operational Acceptance Test of the System (or Subsystem[s] or major components, pursuant to the SCC for GCC Clause 27.2.1) cannot be successfully completed within the period **specified in the SCC**, from the date of Installation or any other period agreed upon in writing by the Purchaser and the Supplier, the Supplier shall be deemed to have fulfilled its obligations with respect to the technical and functional aspects of the Technical Specifications, SCC and/or the Agreed and Finalized Project Plan, and GCC Clause 28.2 and 28.3 shall not apply.

27.3 Operational Acceptance

27.3.1 Subject to GCC Clause 27.4 (Partial Acceptance) below, Operational Acceptance shall occur in respect of the System, when

- (a) the Operational Acceptance Tests, as specified in the Technical Requirements, and/or SCC and/or the Agreed and Finalized Project Plan have been successfully completed; or
- (b) the Operational Acceptance Tests have not been successfully completed or have not been carried out for reasons that are attributable to the Purchaser within the period from the date of Installation or any other agreed-upon period as specified in GCC Clause 27.2.2 above; or
- (c) the Purchaser has put the System into production or use for sixty (60) consecutive days. If the System is put into production or use in this manner, the Supplier shall notify the Purchaser and document such use.

27.3.2 At any time after any of the events set out in GCC Clause 27.3.1 have occurred, the Supplier may give a

notice to the Project Manager requesting the issue of an Operational Acceptance Certificate.

27.3.3 After consultation with the Purchaser, and within fourteen (14) days after receipt of the Supplier's notice, the Project Manager shall:

- (a) issue an Operational Acceptance Certificate; or
- (b) notify the Supplier in writing of any defect or deficiencies or other reason for the failure of the Operational Acceptance Tests; or
- (c) issue the Operational Acceptance Certificate, if the situation covered by GCC Clause 27.3.1 (b) arises.

27.3.4 The Supplier shall use all reasonable endeavors to promptly remedy any defect and/or deficiencies and/or other reasons for the failure of the Operational Acceptance Test that the Project Manager has notified the Supplier of. Once such remedies have been made by the Supplier, the Supplier shall notify the Purchaser, and the Purchaser, with the full cooperation of the Supplier, shall use all reasonable endeavors to promptly carry out retesting of the System or Subsystem. Upon the successful conclusion of the Operational Acceptance Tests, the Supplier shall notify the Purchaser of its request for Operational Acceptance Certification, in accordance with GCC Clause 27.3.3. The Purchaser shall then issue to the Supplier the Operational Acceptance Certification in accordance with GCC Clause 27.3.3 (a), or shall notify the Supplier of further defects, deficiencies, or other reasons for the failure of the Operational Acceptance Test. The procedure set out in this GCC Clause 27.3.4 shall be repeated, as necessary, until an Operational Acceptance Certificate is issued.

27.3.5 If the System or Subsystem fails to pass the Operational Acceptance Test(s) in accordance with GCC Clause 27.2, then either:

- (a) the Purchaser may consider terminating the Contract, pursuant to GCC Clause 41.2.2;
- or
- (b) if the failure to achieve Operational Acceptance within the specified time period is a result of the

failure of the Purchaser to fulfill its obligations under the Contract, then the Supplier shall be deemed to have fulfilled its obligations with respect to the relevant technical and functional aspects of the Contract, and GCC Clauses 30.3 and 30.4 shall not apply.

27.3.6 If within fourteen (14) days after receipt of the Supplier's notice the Project Manager fails to issue the Operational Acceptance Certificate or fails to inform the Supplier in writing of the justifiable reasons why the Project Manager has not issued the Operational Acceptance Certificate, the System or Subsystem shall be deemed to have been accepted as of the date of the Supplier's said notice.

27.4 Partial Acceptance

27.4.1 If so specified in the SCC for GCC Clause 27.2.1, Installation and Commissioning shall be carried out individually for each identified major component or Subsystem(s) of the System. In this event, the provisions in the Contract relating to Installation and Commissioning, including the Operational Acceptance Test, shall apply to each such major component or Subsystem individually, and Operational Acceptance Certificate(s) shall be issued accordingly for each such major component or Subsystem of the System, subject to the limitations contained in GCC Clause 27.4.2.

27.4.2 The issuance of Operational Acceptance Certificates for individual major components or Subsystems pursuant to GCC Clause 27.4.1 shall not relieve the Supplier of its obligation to obtain an Operational Acceptance Certificate for the System as an integrated whole (if so specified in the SCC for GCC Clauses 12.1 and 27.2.1) once all major components and Subsystems have been supplied, installed, tested, and commissioned.

27.4.3 In the case of minor components for the System that by their nature do not require Commissioning or an Operational Acceptance Test (e.g., minor fittings, furnishings or site works, etc.), the Project Manager shall issue an Operational Acceptance Certificate within fourteen (14) days after the fittings and/or furnishings have been delivered and/or installed or the site works have been completed. The Supplier shall, however, use all reasonable endeavors to promptly

remedy any defects or deficiencies in such minor components detected by the Purchaser or Supplier.

F. GUARANTEES AND LIABILITIES

28. Operational Acceptance Time Guarantee

- 28.1 The Supplier guarantees that it shall complete the supply, Installation, Commissioning, and achieve Operational Acceptance of the System (or Subsystems, pursuant to the SCC for GCC Clause 27.2.1) within the time periods specified in the Implementation Schedule in the Technical Requirements Section and/or the Agreed and Finalized Project Plan pursuant to GCC Clause 8.2, or within such extended time to which the Supplier shall be entitled under GCC Clause 40 (Extension of Time for Achieving Operational Acceptance).
- 28.2 If the Supplier fails to supply, install, commission, and achieve Operational Acceptance of the System (or Subsystems pursuant to the SCC for GCC Clause 27.2.1) within the time for achieving Operational Acceptance specified in the Implementation Schedule in the Technical Requirement or the Agreed and Finalized Project Plan, or any extension of the time for achieving Operational Acceptance previously granted under GCC Clause 40 (Extension of Time for Achieving Operational Acceptance), the Supplier shall pay to the Purchaser liquidated damages at the rate **specified in the SCC** as a percentage of the Contract Price, or the relevant part of the Contract Price if a Subsystem has not achieved Operational Acceptance. The aggregate amount of such liquidated damages shall in no event exceed the amount specified in the SCC (“the Maximum”). Once the Maximum is reached, the Purchaser may consider termination of the Contract, pursuant to GCC Clause 41.2.2.
- 28.3 Unless otherwise **specified in the SCC**, liquidated damages payable under GCC Clause 28.2 shall apply only to the failure to achieve Operational Acceptance of the System (and Subsystems) as specified in the Implementation Schedule in the Technical Requirements and/or Agreed and Finalized Project Plan. This Clause 28.3 shall not limit, however, any other rights or remedies the Purchaser may have under the Contract for other delays.
- 28.4 If liquidated damages are claimed by the Purchaser for the System (or Subsystem), the Supplier shall have no further liability whatsoever to the Purchaser in respect to the Operational Acceptance time guarantee for the System (or

Subsystem). However, the payment of liquidated damages shall not in any way relieve the Supplier from any of its obligations to complete the System or from any other of its obligations and liabilities under the Contract.

29. Defect Liability

- 29.1 The Supplier warrants that the System, including all Information Technologies, Materials, and other Goods supplied and Services provided, shall be free from defects in the design, engineering, Materials, and workmanship that prevent the System and/or any of its components from fulfilling the Technical Requirements or that limit in a material fashion the performance, reliability, or extensibility of the System and/or Subsystems. Exceptions and/or limitations, if any, to this warranty with respect to Software (or categories of Software), shall be as **specified in the SCC**. Commercial warranty provisions of products supplied under the Contract shall apply to the extent that they do not conflict with the provisions of this Contract.
- 29.2 The Supplier also warrants that the Information Technologies, Materials, and other Goods supplied under the Contract are new, unused, and incorporate all recent improvements in design that materially affect the System's or Subsystem's ability to fulfill the Technical Requirements.
- 29.3 In addition, the Supplier warrants that: (i) all Goods components to be incorporated into the System form part of the Supplier's and/or Subcontractor's current product lines, (ii) they have been previously released to the market, and (iii) those specific items **identified in the SCC** (if any) have been in the market for at least the minimum periods **specified in the SCC**.
- 29.4 The Warranty Period shall commence from the date of Operational Acceptance of the System (or of any major component or Subsystem for which separate Operational Acceptance is provided for in the Contract) and shall extend for the length of time **specified in the SCC**.
- 29.5 If during the Warranty Period any defect as described in GCC Clause 29.1 should be found in the design, engineering, Materials, and workmanship of the Information Technologies and other Goods supplied or of the Services provided by the Supplier, the Supplier shall promptly, in consultation and agreement with the Purchaser regarding appropriate remedying of the defects, and at its sole cost, repair, replace, or otherwise make good (as the Supplier shall, at its discretion, determine) such defect as well as any damage to the System

caused by such defect. Any defective Information Technologies or other Goods that have been replaced by the Supplier shall remain the property of the Supplier.

29.6 The Supplier shall not be responsible for the repair, replacement, or making good of any defect or of any damage to the System arising out of or resulting from any of the following causes:

- (a) improper operation or maintenance of the System by the Purchaser;
- (b) normal wear and tear;
- (c) use of the System with items not supplied by the Supplier, unless otherwise identified in the Technical Requirements, or approved by the Supplier; or
- (d) modifications made to the System by the Purchaser, or a third party, not approved by the Supplier.

29.7 The Supplier's obligations under this GCC Clause 29 shall not apply to:

- (a) any materials that are normally consumed in operation or have a normal life shorter than the Warranty Period; or
- (b) any designs, specifications, or other data designed, supplied, or specified by or on behalf of the Purchaser or any matters for which the Supplier has disclaimed responsibility, in accordance with GCC Clause 21.1.2.

29.8 The Purchaser shall give the Supplier a notice promptly following the discovery of such defect, stating the nature of any such defect together with all available evidence. The Purchaser shall afford all reasonable opportunity for the Supplier to inspect any such defect. The Purchaser shall afford the Supplier all necessary access to the System and the site to enable the Supplier to perform its obligations under this GCC Clause 29.

29.9 The Supplier may, with the consent of the Purchaser, remove from the site any Information Technologies and other Goods that are defective, if the nature of the defect, and/or any damage to the System caused by the defect, is such that repairs cannot be expeditiously carried out at the site. If the repair, replacement, or making good is of such a character that it may affect the efficiency of the System, the Purchaser may give the Supplier notice requiring that tests of the defective part be

made by the Supplier immediately upon completion of such remedial work, whereupon the Supplier shall carry out such tests.

If such part fails the tests, the Supplier shall carry out further repair, replacement, or making good (as the case may be) until that part of the System passes such tests. The tests shall be agreed upon by the Purchaser and the Supplier.

29.10 If the Supplier fails to commence the work necessary to remedy such defect or any damage to the System caused by such defect within the time period **specified in the SCC**, the Purchaser may, following notice to the Supplier, proceed to do such work or contract a third party (or parties) to do such work, and the reasonable costs incurred by the Purchaser in connection with such work shall be paid to the Purchaser by the Supplier or may be deducted by the Purchaser from any monies due the Supplier or claimed under the Performance Security.

29.11 If the System or Subsystem cannot be used by reason of such defect and/or making good of such defect, the Warranty Period for the System shall be extended by a period equal to the period during which the System or Subsystem could not be used by the Purchaser because of such defect and/or making good of such defect.

29.12 Items substituted for defective parts of the System during the Warranty Period shall be covered by the Defect Liability Warranty for the remainder of the Warranty Period applicable for the part replaced or three (3) months, whichever is greater.

29.13 At the request of the Purchaser and without prejudice to any other rights and remedies that the Purchaser may have against the Supplier under the Contract, the Supplier will offer all possible assistance to the Purchaser to seek warranty services or remedial action from any subcontracted third-party producers or licensors of Goods included in the System, including without limitation assignment or transfer in favor of the Purchaser of the benefit of any warranties given by such producers or licensors to the Supplier.

30. Functional Guarantees

30.1 The Supplier guarantees that, once the Operational Acceptance Certificate(s) has been issued, the System represents a complete, integrated solution to the Purchaser's requirements set forth in the Technical Requirements and it conforms to all other aspects of the Contract. The Supplier acknowledges that GCC Clause 27 regarding Commissioning

and Operational Acceptance governs how technical conformance of the System to the Contract requirements will be determined.

- 30.2 If, for reasons attributable to the Supplier, the System does not conform to the Technical Requirements or does not conform to all other aspects of the Contract, the Supplier shall at its cost and expense make such changes, modifications, and/or additions to the System as may be necessary to conform to the Technical Requirements and meet all functional and performance standards. The Supplier shall notify the Purchaser upon completion of the necessary changes, modifications, and/or additions and shall request the Purchaser to repeat the Operational Acceptance Tests until the System achieves Operational Acceptance.
- 30.3 If the System (or Subsystem[s]) fails to achieve Operational Acceptance, the Purchaser may consider termination of the Contract, pursuant to GCC Clause 41.2.2, and forfeiture of the Supplier's Performance Security in accordance with GCC Clause 13.3 in compensation for the extra costs and delays likely to result from this failure.

31. Intellectual Property Rights Warranty

- 31.1 The Supplier hereby represents and warrants that:
- (a) the System as supplied, installed, tested, and accepted;
 - (b) use of the System in accordance with the Contract; and
 - (c) copying of the Software and Materials provided to the Purchaser in accordance with the Contract

do not and will not infringe any Intellectual Property Rights held by any third party and that it has all necessary rights or at its sole expense shall have secured in writing all transfers of rights and other consents necessary to make the assignments, licenses, and other transfers of Intellectual Property Rights and the warranties set forth in the Contract, and for the Purchaser to own or exercise all Intellectual Property Rights as provided in the Contract. Without limitation, the Supplier shall secure all necessary written agreements, consents, and transfers of rights from its employees and other persons or entities whose services are used for development of the System.

32. Intellectual Property Rights Indemnity

- 32.1 The Supplier shall indemnify and hold harmless the Purchaser and its employees and officers from and against any and all losses, liabilities, and costs (including losses, liabilities, and

costs incurred in defending a claim alleging such a liability), that the Purchaser or its employees or officers may suffer as a result of any infringement or alleged infringement of any Intellectual Property Rights by reason of:

- (a) installation of the System by the Supplier or the use of the System, including the Materials, in the country where the site is located;
- (b) copying of the Software and Materials provided the Supplier in accordance with the Agreement; and
- (c) sale of the products produced by the System in any country, except to the extent that such losses, liabilities, and costs arise as a result of the Purchaser's breach of GCC Clause 32.2.

32.2 Such indemnity shall not cover any use of the System, including the Materials, other than for the purpose indicated by or to be reasonably inferred from the Contract, any infringement resulting from the use of the System, or any products of the System produced thereby in association or combination with any other goods or services not supplied by the Supplier, where the infringement arises because of such association or combination and not because of use of the System in its own right.

32.3 Such indemnities shall also not apply if any claim of infringement:

- (a) is asserted by a parent, subsidiary, or affiliate of the Purchaser's organization;
- (b) is a direct result of a design mandated by the Purchaser's Technical Requirements and the possibility of such infringement was duly noted in the Supplier's Bid; or
- (c) results from the alteration of the System, including the Materials, by the Purchaser or any persons other than the Supplier or a person authorized by the Supplier.

32.4 If any proceedings are brought or any claim is made against the Purchaser arising out of the matters referred to in GCC Clause 32.1, the Purchaser shall promptly give the Supplier notice of such proceedings or claims, and the Supplier may at its own expense and in the Purchaser's name conduct such proceedings or claim and any negotiations for the settlement of any such proceedings or claim.

If the Supplier fails to notify the Purchaser within twenty-eight (28) days after receipt of such notice that it intends to conduct any such proceedings or claim, then the Purchaser shall be free to conduct the same on its own behalf. Unless the Supplier has so failed to notify the Purchaser within the twenty-eight (28) days, the Purchaser shall make no admission that may be prejudicial to the defense of any such proceedings or claim. The Purchaser shall, at the Supplier's request, afford all available assistance to the Supplier in conducting such proceedings or claim and shall be reimbursed by the Supplier for all reasonable expenses incurred in so doing.

32.5 The Purchaser shall indemnify and hold harmless the Supplier and its employees, officers, and Subcontractors from and against any and all losses, liabilities, and costs (including losses, liabilities, and costs incurred in defending a claim alleging such a liability) that the Supplier or its employees, officers, or Subcontractors may suffer as a result of any infringement or alleged infringement of any Intellectual Property Rights arising out of or in connection with any design, data, drawing, specification, or other documents or materials provided to the Supplier in connection with this Contract by the Purchaser or any persons (other than the Supplier) contracted by the Purchaser, except to the extent that such losses, liabilities, and costs arise as a result of the Supplier's breach of GCC Clause 32.8.

32.6 Such indemnity shall not cover

- (a) any use of the design, data, drawing, specification, or other documents or materials, other than for the purpose indicated by or to be reasonably inferred from the Contract;
- (b) any infringement resulting from the use of the design, data, drawing, specification, or other documents or materials, or any products produced thereby, in association or combination with any other Goods or Services not provided by the Purchaser or any other person contracted by the Purchaser, where the infringement arises because of such association or combination and not because of the use of the design, data, drawing, specification, or other documents or materials in its own right.

32.7 Such indemnities shall also not apply:

- (a) if any claim of infringement is asserted by a parent, subsidiary, or affiliate of the Supplier's organization;
- (b) to the extent that any claim of infringement is caused by the alteration, by the Supplier, or any persons contracted by the Supplier, of the design, data, drawing, specification, or other documents or materials provided to the Supplier by the Purchaser or any persons contracted by the Purchaser.

32.8 If any proceedings are brought or any claim is made against the Supplier arising out of the matters referred to in GCC Clause 32.5, the Supplier shall promptly give the Purchaser notice of such proceedings or claims, and the Purchaser may at its own expense and in the Supplier's name conduct such proceedings or claim and any negotiations for the settlement of any such proceedings or claim. If the Purchaser fails to notify the Supplier within twenty-eight (28) days after receipt of such notice that it intends to conduct any such proceedings or claim, then the Supplier shall be free to conduct the same on its own behalf. Unless the Purchaser has so failed to notify the Supplier within the twenty-eight (28) days, the Supplier shall make no admission that may be prejudicial to the defense of any such proceedings or claim. The Supplier shall, at the Purchaser's request, afford all available assistance to the Purchaser in conducting such proceedings or claim and shall be reimbursed by the Purchaser for all reasonable expenses incurred in so doing.

33. Limitation of Liability

- 33.1 Provided the following does not exclude or limit any liabilities of either party in ways not permitted by applicable law:
- (a) the Supplier shall not be liable to the Purchaser, whether in contract, tort, or otherwise, for any indirect or consequential loss or damage, loss of use, loss of production, or loss of profits or interest costs, provided that this exclusion shall not apply to any obligation of the Supplier to pay liquidated damages to the Purchaser; and
 - (b) the aggregate liability of the Supplier to the Purchaser, whether under the Contract, in tort or otherwise, shall not exceed the total Contract Price, provided that this limitation shall not apply to any obligation of the Supplier to indemnify the Purchaser with respect to intellectual property rights infringement.

G. RISK DISTRIBUTION

34. Transfer of Ownership

- 34.1 With the exception of Software and Materials, the ownership of the Information Technologies and other Goods shall be transferred to the Purchaser at the time of Delivery or otherwise under terms that may be agreed upon and specified in the Contract Agreement.
- 34.2 Ownership and the terms of usage of the Software and Materials supplied under the Contract shall be governed by GCC Clause 15 (Copyright) and any elaboration in the Technical Requirements.
- 34.3 Ownership of the Supplier's Equipment used by the Supplier and its Subcontractors in connection with the Contract shall remain with the Supplier or its Subcontractors.

35. Care of the System

- 35.1 The Purchaser shall become responsible for the care and custody of the System or Subsystems upon their Delivery. The Purchaser shall make good at its own cost any loss or damage that may occur to the System or Subsystems from any cause from the date of Delivery until the date of Operational Acceptance of the System or Subsystems, pursuant to GCC Clause 27 (Commissioning and Operational Acceptance), excepting such loss or damage arising from acts or omissions of the Supplier, its employees, or subcontractors.
- 35.2 If any loss or damage occurs to the System or any part of the System by reason of:
- (a) (insofar as they relate to the country where the Project Site is located) nuclear reaction, nuclear radiation, radioactive contamination, a pressure wave caused by aircraft or other aerial objects, or any other occurrences that an experienced contractor could not reasonably foresee, or if reasonably foreseeable could not reasonably make provision for or insure against, insofar as such risks are not normally insurable on the insurance market and are mentioned in the general exclusions of the policy of insurance taken out under GCC Clause 37;
 - (b) any use not in accordance with the Contract, by the Purchaser or any third party;
 - (c) any use of or reliance upon any design, data, or specification provided or designated by or on behalf of the Purchaser, or any such matter for which the Supplier

has disclaimed responsibility in accordance with GCC Clause 21.1.2,

the Purchaser shall pay to the Supplier all sums payable in respect of the System or Subsystems that have achieved Operational Acceptance, notwithstanding that the same be lost, destroyed, or damaged. If the Purchaser requests the Supplier in writing to make good any loss or damage to the System thereby occasioned, the Supplier shall make good the same at the cost of the Purchaser in accordance with GCC Clause 39. If the Purchaser does not request the Supplier in writing to make good any loss or damage to the System thereby occasioned, the Purchaser shall either request a change in accordance with GCC Clause 39, excluding the performance of that part of the System thereby lost, destroyed, or damaged, or, where the loss or damage affects a substantial part of the System, the Purchaser shall terminate the Contract pursuant to GCC Clause 41.1.

**36. Loss of or
Damage to
Property;
Accident or
Injury to
Workers;
Indemnification**

- 35.3 The Purchaser shall be liable for any loss of or damage to any Supplier's Equipment which the Purchaser has authorized to locate within the Purchaser's premises for use in fulfillment of Supplier's obligations under the Contract, except where such loss or damage arises from acts or omissions of the Supplier, its employees, or subcontractors.
- 36.1 The Supplier and each and every Subcontractor shall abide by the job safety, insurance, customs, and immigration measures prevalent and laws in force in the Purchaser's Country.
- 36.2 Subject to GCC Clause 36.3, the Supplier shall indemnify and hold harmless the Purchaser and its employees and officers from and against any and all losses, liabilities and costs (including losses, liabilities, and costs incurred in defending a claim alleging such a liability) that the Purchaser or its employees or officers may suffer as a result of the death or injury of any person or loss of or damage to any property (other than the System, whether accepted or not) arising in connection with the supply, installation, testing, and Commissioning of the System and by reason of the negligence of the Supplier or its Subcontractors, or their employees, officers or agents, except any injury, death, or property damage caused by the negligence of the Purchaser, its contractors, employees, officers, or agents.
- 36.3 If any proceedings are brought or any claim is made against the Purchaser that might subject the Supplier to liability under GCC Clause 36.2, the Purchaser shall promptly give the

Supplier notice of such proceedings or claims, and the Supplier may at its own expense and in the Purchaser's name conduct such proceedings or claim and any negotiations for the settlement of any such proceedings or claim. If the Supplier fails to notify the Purchaser within twenty-eight (28) days after receipt of such notice that it intends to conduct any such proceedings or claim, then the Purchaser shall be free to conduct the same on its own behalf. Unless the Supplier has so failed to notify the Purchaser within the twenty-eight (28) day period, the Purchaser shall make no admission that may be prejudicial to the defense of any such proceedings or claim. The Purchaser shall, at the Supplier's request, afford all available assistance to the Supplier in conducting such proceedings or claim and shall be reimbursed by the Supplier for all reasonable expenses incurred in so doing.

- 36.4 The Purchaser shall indemnify and hold harmless the Supplier and its employees, officers, and Subcontractors from any and all losses, liabilities, and costs (including losses, liabilities, and costs incurred in defending a claim alleging such a liability) that the Supplier or its employees, officers, or Subcontractors may suffer as a result of the death or personal injury of any person or loss of or damage to property of the Purchaser, other than the System not yet achieving Operational Acceptance, that is caused by fire, explosion, or any other perils, in excess of the amount recoverable from insurances procured under GCC Clause 37 (Insurances), provided that such fire, explosion, or other perils were not caused by any act or failure of the Supplier.
- 36.5 If any proceedings are brought or any claim is made against the Supplier that might subject the Purchaser to liability under GCC Clause 36.4, the Supplier shall promptly give the Purchaser notice of such proceedings or claims, and the Purchaser may at its own expense and in the Supplier's name conduct such proceedings or claim and any negotiations for the settlement of any such proceedings or claim. If the Purchaser fails to notify the Supplier within twenty-eight (28) days after receipt of such notice that it intends to conduct any such proceedings or claim, then the Supplier shall be free to conduct the same on its own behalf. Unless the Purchaser has so failed to notify the Supplier within the twenty-eight (28) days, the Supplier shall make no admission that may be prejudicial to the defense of any such proceedings or claim. The Supplier shall, at the Purchaser's request, afford all available assistance to the Purchaser in conducting such

proceedings or claim and shall be reimbursed by the Purchaser for all reasonable expenses incurred in so doing.

36.6 The party entitled to the benefit of an indemnity under this GCC Clause 36 shall take all reasonable measures to mitigate any loss or damage that has occurred. If the party fails to take such measures, the other party's liabilities shall be correspondingly reduced.

37. Insurances

37.1 The Supplier shall at its expense take out and maintain in effect, or cause to be taken out and maintained in effect, during the performance of the Contract, the insurance set forth below. The identity of the insurers and the form of the policies shall be subject to the approval of the Purchaser, who should not unreasonably withhold such approval.

(a) Cargo Insurance During Transport

as applicable, 110 percent of the price of the Information Technologies and other Goods in a freely convertible currency, covering the Goods from physical loss or damage during shipment through receipt at the Project Site.

(b) Installation "All Risks" Insurance

as applicable, 110 percent of the price of the Information Technologies and other Goods covering the Goods at the site from all risks of physical loss or damage (excluding only perils commonly excluded under "all risks" insurance policies of this type by reputable insurers) occurring prior to Operational Acceptance of the System.

(c) Third-Party Liability Insurance

On terms as **specified in the SCC**, covering bodily injury or death suffered by third parties (including the Purchaser's personnel) and loss of or damage to property (including the Purchaser's property and any Subsystems that have been accepted by the Purchaser) occurring in connection with the supply and installation of the Information System.

(d) Automobile Liability Insurance

In accordance with the statutory requirements prevailing in the Purchaser's Country, covering use of all vehicles used by the Supplier or its Subcontractors (whether or

not owned by them) in connection with the execution of the Contract.

(e) Other Insurance (if any), as **specified in the SCC**.

- 37.2 The Purchaser shall be named as co-insured under all insurance policies taken out by the Supplier pursuant to GCC Clause 37.1, except for the Third-Party Liability, and the Supplier's Subcontractors shall be named as co-insured under all insurance policies taken out by the Supplier pursuant to GCC Clause 37.1 except for Cargo Insurance During Transport. All insurer's rights of subrogation against such co-insured for losses or claims arising out of the performance of the Contract shall be waived under such policies.
- 37.3 The Supplier shall deliver to the Purchaser certificates of insurance (or copies of the insurance policies) as evidence that the required policies are in full force and effect.
- 37.4 The Supplier shall ensure that, where applicable, its Subcontractor(s) shall take out and maintain in effect adequate insurance policies for their personnel and vehicles and for work executed by them under the Contract, unless such Subcontractors are covered by the policies taken out by the Supplier.
- 37.5 If the Supplier fails to take out and/or maintain in effect the insurance referred to in GCC Clause 37.1, the Purchaser may take out and maintain in effect any such insurance and may from time to time deduct from any amount due the Supplier under the Contract any premium that the Purchaser shall have paid to the insurer or may otherwise recover such amount as a debt due from the Supplier.
- 37.6 Unless otherwise provided in the Contract, the Supplier shall prepare and conduct all and any claims made under the policies effected by it pursuant to this GCC Clause 37, and all monies payable by any insurers shall be paid to the Supplier. The Purchaser shall give to the Supplier all such reasonable assistance as may be required by the Supplier in connection with any claim under the relevant insurance policies. With respect to insurance claims in which the Purchaser's interest is involved, the Supplier shall not give any release or make any compromise with the insurer without the prior written consent of the Purchaser. With respect to insurance claims in which the Supplier's interest is involved, the Purchaser shall

not give any release or make any compromise with the insurer without the prior written consent of the Supplier.

38. Force Majeure

38.1 “Force Majeure” shall mean any event beyond the reasonable control of the Purchaser or of the Supplier, as the case may be, and which is unavoidable notwithstanding the reasonable care of the party affected and shall include, without limitation, the following:

- (a) war, hostilities, or warlike operations (whether a state of war be declared or not), invasion, act of foreign enemy, and civil war;
- (b) rebellion, revolution, insurrection, mutiny, usurpation of civil or military government, conspiracy, riot, civil commotion, and terrorist acts;
- (c) confiscation, nationalization, mobilization, commandeering or requisition by or under the order of any government or de jure or de facto authority or ruler, or any other act or failure to act of any local state or national government authority;
- (d) strike, sabotage, lockout, embargo, import restriction, port congestion, lack of usual means of public transportation and communication, industrial dispute, shipwreck, shortage or restriction of power supply, epidemics, quarantine, and plague;
- (e) earthquake, landslide, volcanic activity, fire, flood or inundation, tidal wave, typhoon or cyclone, hurricane, storm, lightning, or other inclement weather condition, nuclear and pressure waves, or other natural or physical disaster;
- (f) failure, by the Supplier, to obtain the necessary export permit(s) from the governments of the Country(s) of Origin of the Information Technologies or other Goods, or Supplier’s Equipment provided that the Supplier has made all reasonable efforts to obtain the required export permit(s), including the exercise of due diligence in determining the eligibility of the System and all of its components for receipt of the necessary export permits.

38.2 If either party is prevented, hindered, or delayed from or in performing any of its obligations under the Contract by an event of Force Majeure, then it shall notify the other in writing of the occurrence of such event and the circumstances of the

event of Force Majeure within fourteen (14) days after the occurrence of such event.

- 38.3 The party who has given such notice shall be excused from the performance or punctual performance of its obligations under the Contract for so long as the relevant event of Force Majeure continues and to the extent that such party's performance is prevented, hindered, or delayed. The Time for Achieving Operational Acceptance shall be extended in accordance with GCC Clause 40 (Extension of Time for Achieving Operational Acceptance).
- 38.4 The party or parties affected by the event of Force Majeure shall use reasonable efforts to mitigate the effect of the event of Force Majeure upon its or their performance of the Contract and to fulfill its or their obligations under the Contract, but without prejudice to either party's right to terminate the Contract under GCC Clause 38.6.
- 38.5 No delay or nonperformance by either party to this Contract caused by the occurrence of any event of Force Majeure shall:
- (a) constitute a default or breach of the Contract;
 - (b) (subject to GCC Clauses 35.2, 38.3, and 38.4) give rise to any claim for damages or additional cost or expense occasioned by the delay or nonperformance,
- if, and to the extent that, such delay or nonperformance is caused by the occurrence of an event of Force Majeure.
- 38.6 If the performance of the Contract is substantially prevented, hindered, or delayed for a single period of more than sixty (60) days or an aggregate period of more than one hundred and twenty (120) days on account of one or more events of Force Majeure during the time period covered by the Contract, the parties will attempt to develop a mutually satisfactory solution, failing which, either party may terminate the Contract by giving a notice to the other.
- 38.7 In the event of termination pursuant to GCC Clause 38.6, the rights and obligations of the Purchaser and the Supplier shall be as specified in GCC Clauses 41.1.2 and 41.1.3.
- 38.8 Notwithstanding GCC Clause 38.5, Force Majeure shall not apply to any obligation of the Purchaser to make payments to the Supplier under this Contract.

H. CHANGE IN CONTRACT ELEMENTS

39. Changes to the System

39.1 Introducing a Change

39.1.1 Subject to GCC Clauses 39.2.5 and 39.2.7, the Purchaser shall have the right to propose, and subsequently require, the Project Manager to order the Supplier from time to time during the performance of the Contract to make any change, modification, addition, or deletion to, in, or from the System (interchangeably called “Change”), provided that such Change falls within the general scope of the System, does not constitute unrelated work, and is technically practicable, taking into account both the state of advancement of the System and the technical compatibility of the Change envisaged with the nature of the System as originally specified in the Contract.

A Change may involve, but is not restricted to, the substitution of updated Information Technologies and related Services in accordance with GCC Clause 23 (Product Upgrades).

39.1.2 The Supplier may from time to time during its performance of the Contract propose to the Purchaser (with a copy to the Project Manager) any Change that the Supplier considers necessary or desirable to improve the quality or efficiency of the System. The Purchaser may at its discretion approve or reject any Change proposed by the Supplier.

39.1.3 Notwithstanding GCC Clauses 39.1.1 and 39.1.2, no change made necessary because of any default of the Supplier in the performance of its obligations under the Contract shall be deemed to be a Change, and such change shall not result in any adjustment of the Contract Price or the Time for Achieving Operational Acceptance.

39.1.4 The procedure on how to proceed with and execute Changes is specified in GCC Clauses 39.2 and 39.3, and further details and sample forms are provided in the Sample Forms Section in the Bidding Documents.

39.1.5 Moreover, the Purchaser and Supplier will agree, during development of the Project Plan, to a date prior to the scheduled date for Operational Acceptance,

after which the Technical Requirements for the System shall be “frozen.” Any Change initiated after this time will be dealt with after Operational Acceptance.

39.2 Changes Originating from Purchaser

39.2.1 If the Purchaser proposes a Change pursuant to GCC Clauses 39.1.1, it shall send to the Supplier a “Request for Change Proposal,” requiring the Supplier to prepare and furnish to the Project Manager as soon as reasonably practicable a “Change Proposal,” which shall include the following:

- (a) brief description of the Change;
- (b) impact on the Time for Achieving Operational Acceptance;
- (c) detailed estimated cost of the Change;
- (d) effect on Functional Guarantees (if any);
- (e) effect on any other provisions of the Contract.

39.2.2 Prior to preparing and submitting the “Change Proposal,” the Supplier shall submit to the Project Manager an “Change Estimate Proposal,” which shall be an estimate of the cost of preparing the Change Proposal, plus a first approximation of the suggested approach and cost for implementing the changes. Upon receipt of the Supplier’s Change Estimate Proposal, the Purchaser shall do one of the following:

- (a) accept the Supplier’s estimate with instructions to the Supplier to proceed with the preparation of the Change Proposal;
- (b) advise the Supplier of any part of its Change Estimate Proposal that is unacceptable and request the Supplier to review its estimate;
- (c) advise the Supplier that the Purchaser does not intend to proceed with the Change.

39.2.3 Upon receipt of the Purchaser’s instruction to proceed under GCC Clause 39.2.2 (a), the Supplier shall, with proper expedition, proceed with the preparation of the Change Proposal, in accordance with GCC Clause 39.2.1. The Supplier, at its discretion, may

specify a validity period for the Change Proposal, after which if the Purchaser and Supplier has not reached agreement in accordance with GCC Clause 39.2.6, then GCC Clause 39.2.7 shall apply.

- 39.2.4 The pricing of any Change shall, as far as practicable, be calculated in accordance with the rates and prices included in the Contract. If the nature of the Change is such that the Contract rates and prices are inequitable, the parties to the Contract shall agree on other specific rates to be used for valuing the Change.
- 39.2.5 If before or during the preparation of the Change Proposal it becomes apparent that the aggregate impact of compliance with the Request for Change Proposal and with all other Change Orders that have already become binding upon the Supplier under this GCC Clause 39 would be to increase or decrease the Contract Price as originally set forth in Article 2 (Contract Price) of the Contract Agreement by more than fifteen (15) percent, the Supplier may give a written notice of objection to this Request for Change Proposal prior to furnishing the Change Proposal. If the Purchaser accepts the Supplier's objection, the Purchaser shall withdraw the proposed Change and shall notify the Supplier in writing of its acceptance.

The Supplier's failure to so object to a Request for Change Proposal shall neither affect its right to object to any subsequent requested Changes or Change Orders, nor affect its right to take into account, when making such subsequent objection, the percentage increase or decrease in the Contract Price that any Change not objected to by the Supplier represents.

- 39.2.6 Upon receipt of the Change Proposal, the Purchaser and the Supplier shall mutually agree upon all matters contained in the Change Proposal. Within fourteen (14) days after such agreement, the Purchaser shall, if it intends to proceed with the Change, issue the Supplier a Change Order. If the Purchaser is unable to reach a decision within fourteen (14) days, it shall notify the Supplier with details of when the Supplier can expect a decision. If the Purchaser decides not to proceed with the Change for whatever reason, it shall, within the said period of fourteen (14) days, notify the Supplier accordingly. Under such circumstances, the

Supplier shall be entitled to reimbursement of all costs reasonably incurred by it in the preparation of the Change Proposal, provided that these do not exceed the amount given by the Supplier in its Change Estimate Proposal submitted in accordance with GCC Clause 39.2.2.

- 39.2.7 If the Purchaser and the Supplier cannot reach agreement on the price for the Change, an equitable adjustment to the Time for Achieving Operational Acceptance, or any other matters identified in the Change Proposal, the Change will not be implemented. However, this provision does not limit the rights of either party under GCC Clause 6 (Settlement of Disputes).

39.3 Changes Originating from Supplier

If the Supplier proposes a Change pursuant to GCC Clause 39.1.2, the Supplier shall submit to the Project Manager a written "Application for Change Proposal," giving reasons for the proposed Change and including the information specified in GCC Clause 39.2.1. Upon receipt of the Application for Change Proposal, the parties shall follow the procedures outlined in GCC Clauses 39.2.6 and 39.2.7. However, should the Purchaser choose not to proceed or the Purchaser and the Supplier cannot come to agreement on the change during any validity period that the Supplier may specify in its Application for Change Proposal, the Supplier shall not be entitled to recover the costs of preparing the Application for Change Proposal, unless subject to an agreement between the Purchaser and the Supplier to the contrary.

40. Extension of Time for Achieving Operational Acceptance

- 40.1 The time(s) for achieving Operational Acceptance specified in the Schedule of Implementation shall be extended if the Supplier is delayed or impeded in the performance of any of its obligations under the Contract by reason of any of the following:
- (a) any Change in the System as provided in GCC Clause 39 (Change in the Information System);
 - (b) any occurrence of Force Majeure as provided in GCC Clause 38 (Force Majeure);
 - (c) default of the Purchaser; or

- (d) any other matter specifically mentioned in the Contract;
- by such period as shall be fair and reasonable in all the circumstances and as shall fairly reflect the delay or impediment sustained by the Supplier.
- 40.2 Except where otherwise specifically provided in the Contract, the Supplier shall submit to the Project Manager a notice of a claim for an extension of the time for achieving Operational Acceptance, together with particulars of the event or circumstance justifying such extension as soon as reasonably practicable after the commencement of such event or circumstance. As soon as reasonably practicable after receipt of such notice and supporting particulars of the claim, the Purchaser and the Supplier shall agree upon the period of such extension. In the event that the Supplier does not accept the Purchaser's estimate of a fair and reasonable time extension, the Supplier shall be entitled to refer the matter to the provisions for the Settlement of Disputes pursuant to GCC Clause 6.
- 40.3 The Supplier shall at all times use its reasonable efforts to minimize any delay in the performance of its obligations under the Contract.

41. Termination

41.1 Termination for Purchaser's Convenience

- 41.1.1 The Purchaser may at any time terminate the Contract for any reason by giving the Supplier a notice of termination that refers to this GCC Clause 41.1.
- 41.1.2 Upon receipt of the notice of termination under GCC Clause 41.1.1, the Supplier shall either as soon as reasonably practical or upon the date specified in the notice of termination
- (a) cease all further work, except for such work as the Purchaser may specify in the notice of termination for the sole purpose of protecting that part of the System already executed, or any work required to leave the site in a clean and safe condition;
 - (b) terminate all subcontracts, except those to be assigned to the Purchaser pursuant to GCC Clause 41.1.2 (d) (ii) below;
 - (c) remove all Supplier's Equipment from the site, repatriate the Supplier's and its Subcontractors'

personnel from the site, remove from the site any wreckage, rubbish, and debris of any kind;

- (d) in addition, the Supplier, subject to the payment specified in GCC Clause 41.1.3, shall
 - (i) deliver to the Purchaser the parts of the System executed by the Supplier up to the date of termination;
 - (ii) to the extent legally possible, assign to the Purchaser all right, title, and benefit of the Supplier to the System, or Subsystem, as at the date of termination, and, as may be required by the Purchaser, in any subcontracts concluded between the Supplier and its Subcontractors;
 - (iii) deliver to the Purchaser all nonproprietary drawings, specifications, and other documents prepared by the Supplier or its Subcontractors as of the date of termination in connection with the System.

41.1.3 In the event of termination of the Contract under GCC Clause 41.1.1, the Purchaser shall pay to the Supplier the following amounts:

- (a) the Contract Price, properly attributable to the parts of the System executed by the Supplier as of the date of termination;
- (b) the costs reasonably incurred by the Supplier in the removal of the Supplier's Equipment from the site and in the repatriation of the Supplier's and its Subcontractors' personnel;
- (c) any amount to be paid by the Supplier to its Subcontractors in connection with the termination of any subcontracts, including any cancellation charges;
- (d) costs incurred by the Supplier in protecting the System and leaving the site in a clean and safe condition pursuant to GCC Clause 41.1.2 (a); and
- (e) the cost of satisfying all other obligations, commitments, and claims that the Supplier may in good faith have undertaken with third parties in

connection with the Contract and that are not covered by GCC Clauses 41.1.3 (a) through (d) above.

41.2 Termination for Supplier's Default

41.2.1 The Purchaser, without prejudice to any other rights or remedies it may possess, may terminate the Contract forthwith in the following circumstances by giving a notice of termination and its reasons therefore to the Supplier, referring to this GCC Clause 41.2:

- (a) if the Supplier becomes bankrupt or insolvent, has a receiving order issued against it, compounds with its creditors, or, if the Supplier is a corporation, a resolution is passed or order is made for its winding up (other than a voluntary liquidation for the purposes of amalgamation or reconstruction), a receiver is appointed over any part of its undertaking or assets, or if the Supplier takes or suffers any other analogous action in consequence of debt;
- (b) if the Supplier assigns or transfers the Contract or any right or interest therein in violation of the provision of GCC Clause 42 (Assignment); or
- (c) if the Supplier, in the judgment of the Purchaser, has engaged in corrupt, fraudulent, collusive, coercive or obstructive practices, in competing for or in executing the Contract, including but not limited to willful misrepresentation of facts concerning ownership of Intellectual Property Rights in, or proper authorization and/or licenses from the owner to offer, the hardware, software, or materials provided under this Contract.

For the purposes of this Clause:

- (i) "corrupt practice"¹ is the offering, giving, receiving or soliciting, directly or indirectly, of anything of value to
-

influence improperly the actions of another party;

- (ii) “fraudulent practice”¹ is any act or omission, including a misrepresentation, that knowingly or recklessly misleads, or attempts to mislead, a party to obtain a financial or other benefit or to avoid an obligation;
 - (iii) “collusive practice”² is an arrangement between two or more parties designed to achieve an improper purpose, including to influence improperly the actions of another party;
 - (iv) “coercive practice”³ is impairing or harming, or threatening to impair or harm, directly or indirectly, any party or the property of the party to influence improperly the actions of a party;
 - (v) “obstructive practice” is
 - (aa) deliberately destroying, falsifying, altering or concealing of evidence material to the investigation or making false statements to investigators in order to materially impede a Bank investigation into allegations of a corrupt, fraudulent, coercive or collusive practice; and/or threatening, harassing or intimidating any party to prevent it from disclosing its knowledge of matters relevant to the investigation or from pursuing the investigation; or
 - (bb) acts intended to materially impede the exercise of the Bank’s inspection and audit rights provided for under Sub-Clause 9.8.
-

41.2.2 If the Supplier:

- (a) has abandoned or repudiated the Contract;
- (b) has without valid reason failed to commence work on the System promptly;
- (c) persistently fails to execute the Contract in accordance with the Contract or persistently neglects to carry out its obligations under the Contract without just cause;
- (d) refuses or is unable to provide sufficient Materials, Services, or labor to execute and complete the System in the manner specified in the Agreed and Finalized Project Plan furnished under GCC Clause 19 at rates of progress that give reasonable assurance to the Purchaser that the Supplier can attain Operational Acceptance of the System by the Time for Achieving Operational Acceptance as extended;

then the Purchaser may, without prejudice to any other rights it may possess under the Contract, give a notice to the Supplier stating the nature of the default and requiring the Supplier to remedy the same. If the Supplier fails to remedy or to take steps to remedy the same within fourteen (14) days of its receipt of such notice, then the Purchaser may terminate the Contract forthwith by giving a notice of termination to the Supplier that refers to this GCC Clause 41.2.

41.2.3 Upon receipt of the notice of termination under GCC Clauses 41.2.1 or 41.2.2, the Supplier shall, either immediately or upon such date as is specified in the notice of termination:

- (a) cease all further work, except for such work as the Purchaser may specify in the notice of termination for the sole purpose of protecting that part of the System already executed or any work required to leave the site in a clean and safe condition;
- (b) terminate all subcontracts, except those to be assigned to the Purchaser pursuant to GCC Clause 41.2.3 (d) below;

- (c) deliver to the Purchaser the parts of the System executed by the Supplier up to the date of termination;
 - (d) to the extent legally possible, assign to the Purchaser all right, title and benefit of the Supplier to the System or Subsystems as at the date of termination, and, as may be required by the Purchaser, in any subcontracts concluded between the Supplier and its Subcontractors;
 - (e) deliver to the Purchaser all drawings, specifications, and other documents prepared by the Supplier or its Subcontractors as at the date of termination in connection with the System.
- 41.2.4 The Purchaser may enter upon the site, expel the Supplier, and complete the System itself or by employing any third party. Upon completion of the System or at such earlier date as the Purchaser thinks appropriate, the Purchaser shall give notice to the Supplier that such Supplier's Equipment will be returned to the Supplier at or near the site and shall return such Supplier's Equipment to the Supplier in accordance with such notice. The Supplier shall thereafter without delay and at its cost remove or arrange removal of the same from the site.
- 41.2.5 Subject to GCC Clause 41.2.6, the Supplier shall be entitled to be paid the Contract Price attributable to the portion of the System executed as at the date of termination and the costs, if any, incurred in protecting the System and in leaving the site in a clean and safe condition pursuant to GCC Clause 41.2.3 (a). Any sums due the Purchaser from the Supplier accruing prior to the date of termination shall be deducted from the amount to be paid to the Supplier under this Contract.
- 41.2.6 If the Purchaser completes the System, the cost of completing the System by the Purchaser shall be determined. If the sum that the Supplier is entitled to be paid, pursuant to GCC Clause 41.2.5, plus the reasonable costs incurred by the Purchaser in completing the System, exceeds the Contract Price, the Supplier shall be liable for such excess. If such excess is greater than the sums due the Supplier under GCC Clause 41.2.5, the Supplier shall pay the

balance to the Purchaser, and if such excess is less than the sums due the Supplier under GCC Clause 41.2.5, the Purchaser shall pay the balance to the Supplier. The Purchaser and the Supplier shall agree, in writing, on the computation described above and the manner in which any sums shall be paid.

41.3 Termination by Supplier

41.3.1 If:

- (a) the Purchaser has failed to pay the Supplier any sum due under the Contract within the specified period, has failed to approve any invoice or supporting documents without just cause **pursuant to the SCC**, or commits a substantial breach of the Contract, the Supplier may give a notice to the Purchaser that requires payment of such sum, with interest on this sum as stipulated in GCC Clause 12.3, requires approval of such invoice or supporting documents, or specifies the breach and requires the Purchaser to remedy the same, as the case may be. If the Purchaser fails to pay such sum together with such interest, fails to approve such invoice or supporting documents or give its reasons for withholding such approval, fails to remedy the breach or take steps to remedy the breach within fourteen (14) days after receipt of the Supplier's notice; or
- (b) the Supplier is unable to carry out any of its obligations under the Contract for any reason attributable to the Purchaser, including but not limited to the Purchaser's failure to provide possession of or access to the site or other areas or failure to obtain any governmental permit necessary for the execution and/or completion of the System;

then the Supplier may give a notice to the Purchaser of such events, and if the Purchaser has failed to pay the outstanding sum, to approve the invoice or supporting documents, to give its reasons for withholding such approval, or to remedy the breach within twenty-eight (28) days of such notice, or if the Supplier is still unable to carry out any of its obligations under the Contract for any reason attributable to the Purchaser within twenty-eight (28)

days of the said notice, the Supplier may by a further notice to the Purchaser referring to this GCC Clause 41.3.1, forthwith terminate the Contract.

- 41.3.2 The Supplier may terminate the Contract immediately by giving a notice to the Purchaser to that effect, referring to this GCC Clause 41.3.2, if the Purchaser becomes bankrupt or insolvent, has a receiving order issued against it, compounds with its creditors, or, being a corporation, if a resolution is passed or order is made for its winding up (other than a voluntary liquidation for the purposes of amalgamation or reconstruction), a receiver is appointed over any part of its undertaking or assets, or if the Purchaser takes or suffers any other analogous action in consequence of debt.
- 41.3.3 If the Contract is terminated under GCC Clauses 41.3.1 or 41.3.2, then the Supplier shall immediately:
- (a) cease all further work, except for such work as may be necessary for the purpose of protecting that part of the System already executed, or any work required to leave the site in a clean and safe condition;
 - (b) terminate all subcontracts, except those to be assigned to the Purchaser pursuant to Clause 41.3.3 (d) (ii);
 - (c) remove all Supplier's Equipment from the site and repatriate the Supplier's and its Subcontractor's personnel from the site.
 - (d) In addition, the Supplier, subject to the payment specified in GCC Clause 41.3.4, shall:
 - (i) deliver to the Purchaser the parts of the System executed by the Supplier up to the date of termination;
 - (ii) to the extent legally possible, assign to the Purchaser all right, title, and benefit of the Supplier to the System, or Subsystems, as of the date of termination, and, as may be required by the Purchaser, in any

subcontracts concluded between the Supplier and its Subcontractors;

- (iii) to the extent legally possible, deliver to the Purchaser all drawings, specifications, and other documents prepared by the Supplier or its Subcontractors as of the date of termination in connection with the System.

41.3.4 If the Contract is terminated under GCC Clauses 41.3.1 or 41.3.2, the Purchaser shall pay to the Supplier all payments specified in GCC Clause 41.1.3, and reasonable compensation for all loss, except for loss of profit, or damage sustained by the Supplier arising out of, in connection with, or in consequence of such termination.

41.3.5 Termination by the Supplier pursuant to this GCC Clause 41.3 is without prejudice to any other rights or remedies of the Supplier that may be exercised in lieu of or in addition to rights conferred by GCC Clause 41.3.

41.4 In this GCC Clause 41, the expression “portion of the System executed” shall include all work executed, Services provided, and all Information Technologies, or other Goods acquired (or subject to a legally binding obligation to purchase) by the Supplier and used or intended to be used for the purpose of the System, up to and including the date of termination.

41.5 In this GCC Clause 41, in calculating any monies due from the Purchaser to the Supplier, account shall be taken of any sum previously paid by the Purchaser to the Supplier under the Contract, including any advance payment paid **pursuant to the SCC**.

42. Assignment

42.1 Neither the Purchaser nor the Supplier shall, without the express prior written consent of the other, assign to any third party the Contract or any part thereof, or any right, benefit, obligation, or interest therein or thereunder, except that the Supplier shall be entitled to assign either absolutely or by way of charge any monies due and payable to it or that may become due and payable to it under the Contract.

SECTION V. SPECIAL CONDITIONS OF CONTRACT (SCC)

Table of Clauses

A. Contract and Interpretation	132
1. Definitions (GCC Clause 1).....	132
2. Contract Documents (GCC Clause 2).....	132
3. Interpretation (GCC Clause 3).....	133
4. Notices (GCC Clause 4).....	133
5. Governing Law (GCC Clause 5).....	133
6. Settlement of Disputes (GCC Clause 6)	133
B. Subject Matter of Contract	134
7. Scope of the System (GCC Clause 7).....	134
8. Time for Commencement and Operational Acceptance (GCC Clause 8)	134
9. Supplier’s Responsibilities (GCC Clause 9).....	134
10. Purchaser’s Responsibilities (GCC Clause 10).....	134
C. Payment.....	134
11. Contract Price (GCC Clause 11).....	134
12. Terms of Payment (GCC Clause 12)	134
13. Securities (GCC Clause 13).....	137
14. Taxes and Duties (GCC Clause 14).....	137
D. Intellectual Property	137
15. Copyright (GCC Clause 15).....	137
17. Confidential Information (GCC Clause 17).....	138
E. Supply, Installation, Testing, Commissioning, and Acceptance of the System	138
18. Representatives (GCC Clause 18)	138
19. Project Plan (GCC Clause 19)	139
20. Subcontracting (GCC Clause 20).....	140
21. Design and Engineering (GCC Clause 21)	140
22. Procurement, Delivery, and Transport (GCC Clause 22).....	140
23. Product Upgrades (GCC Clause 23)	141
24. Implementation, Installation, and Other Services (GCC Clause 24).....	141
25. Inspections and Tests (GCC Clause 25)	141
26. Installation of the System (GCC Clause 26).....	141
27. Commissioning and Operational Acceptance (GCC Clause 27)	141
F. Guarantees and Liabilities.....	142
28. Operational Acceptance Time Guarantee (GCC Clause 28)	142
29. Defect Liability (GCC Clause 29)	142
30. Functional Guarantees (GCC Clause 30).....	142
31. Intellectual Property Rights Warranty (GCC Clause 31)	142
32. Intellectual Property Rights Indemnity (GCC Clause 32)	143
33. Limitation of Liability (GCC Clause 33).....	143
G. Risk Distribution.....	143

34. Transfer of Ownership (GCC Clause 34)	143
35. Care of the System (GCC Clause 35)	143
36. Loss of or Damage to Property; Accident or Injury to Workers; Indemnification (GCC Clause 36).....	143
37. Insurances (GCC Clause 37).....	143
38. Force Majeure (GCC Clause 38)	144
H. Change in Contract Elements.....	144
39. Changes to the System (GCC Clause 39)	144
40. Extension of Time for Achieving Operational Acceptance (GCC Clause 40)	144
41. Termination (GCC Clause 41).....	144
42. Assignment (GCC Clause 42).....	144

Special Conditions of Contract

The following Special Conditions of Contract (SCC) shall supplement or amend the General Conditions of Contract (GCC). Whenever there is a conflict, the provisions of the SCC shall prevail over those in the General Conditions of Contract. For the purposes of clarity, any referenced GCC clause numbers are indicated in the left column of the SCC.

A. CONTRACT AND INTERPRETATION

1. Definitions (GCC Clause 1)

GCC 1.1 (a) (ix)	The applicable edition of the Procurement Guidelines is dated: 1ST JULY, 2016.
GCC 1.1 (b) (i)	The Purchaser is: KENYA REVENUE AUTHORITY (KRA).
GCC 1.1 (b) (ii)	The Project Manager is: AG. CHIEF MANAGER, ICT.
GCC 1.1 (e) (i)	The Purchaser's Country is: KENYA.
GCC 1.1 (e) (iii)	The Project Site(s) is/are: LOT 1: KILINDINI PORT, MOMBASA. LOT 2: KRA DATA CENTERS (NAIROBI) AND TEN(10) OTHER SELECTED STATIONS WITHIN AND OUTSIDE NAIROBI
GCC 1.1 (e) (x)	THE CONTRACT SHALL CONTINUE IN FORCE UNTIL THE INFORMATION SYSTEM AND ALL THE SERVICES HAVE BEEN PROVIDED UNLESS THE CONTRACT IS TERMINATED EARLIER IN ACCORDANCE WITH THE TERMS SET OUT IN THE CONTRACT.
GCC 1.1. (e) (xii)	The Post-Warranty Services Period is TWELVE (12) MONTHS from completion and hand-over.

2. Contract Documents (GCC Clause 2)

GCC 2	THERE ARE NO SPECIAL CONDITIONS OF CONTRACT APPLICABLE TO GCC CLAUSE 2.
-------	--

3. Interpretation (GCC Clause 3)

GCC 3.1.1	The Contract's governing language is: ENGLISH.
-----------	---

4. Notices (GCC Clause 4)

GCC 4.3	<p>Address of the Project Manager:</p> <p>KENYA REVENUE AUTHORITY</p> <p>P.O. BOX 48240-00100, NAIROBI, KENYA.</p> <p>eprocurement@kra.go.ke</p> <p>For Electronic Data Interchange (EDI) the Purchaser and Supplier will use the following standards, protocols, addresses, and procedures: NONE.</p>
---------	---

5. Governing Law (GCC Clause 5)

GCC 5.1	The Contract shall be interpreted in accordance with the laws of: KENYA.
---------	---

6. Settlement of Disputes (GCC Clause 6)

GCC 6.1.4	The Appointing Authority for the Adjudicator is: THE KENYA NATIONAL CHAMBER OF COMMERCE AND INDUSTRY
GCC 6.2.3	<p>If the Supplier is foreign (including a Joint Venture when at least one partner is foreign), Arbitration proceedings shall be conducted in accordance with the rules of arbitration of UNCITRAL. These rules, in the version in force at the time of the request for arbitration, will be deemed to form part of this Contract.</p> <p>If the Supplier is a national of the Purchaser's country, Any dispute between the Purchaser and a Supplier arising in connection with the present Contract shall be referred to arbitration in accordance with the laws of the Purchaser's country.</p>

B. SUBJECT MATTER OF CONTRACT

7. Scope of the System (GCC Clause 7)

GCC 7.3	The Supplier's obligations under the Contract will include the following recurrent cost items, as identified in the Recurrent Cost tables in the Supplier's Bid: NONE .
---------	--

8. Time for Commencement and Operational Acceptance (GCC Clause 8)

GCC 8.1	The Supplier shall commence work on the System within: THIRTY (30) days from the Effective Date of the Contract.
GCC 8.2	Operational Acceptance will occur on or before: 31ST DECEMBER, 2020 .

9. Supplier's Responsibilities (GCC Clause 9)

GCC 9.9	The Supplier shall have the following additional responsibilities: NONE .
---------	--

10. Purchaser's Responsibilities (GCC Clause 10)

GCC 10.12	The Purchaser shall have the following additional responsibilities: NONE .
-----------	---

C. PAYMENT

11. Contract Price (GCC Clause 11)

GCC 11.2 (b)	Adjustments to the Contract Price shall be as follows: NONE .
--------------	--

12. Terms of Payment (GCC Clause 12)

GCC 12.1	Subject to the provisions of GCC Clause 12 (Terms of Payment), the Purchaser shall pay the Contract Price to the Supplier according to the categories and in the manner specified below. Only the categories Advance Payment and Complete System Integration relate to the entire Contract Price. In other payment categories, the term "total Contract Price" means the total cost of goods or
----------	---

	<p>services under the specific payment category. Within each such category, the Contract Implementation Schedule may trigger pro-rata payments for the portion of the total Contract Price for the category corresponding to the goods or services actually Delivered, Installed, or Operationally Accepted, at unit prices and in the currencies specified in the Price Schedules of the Contract Agreement.</p> <p>LOT 1:</p> <p>(a) Advance Payment</p> <p>TWENTY PERCENT (20%) of the entire Contract Price, exclusive of all Recurrent Costs, shall be paid against receipt of a claim accompanied by the Advance Payment Security specified in GCC Clause 13.2.</p> <p>(b) TWENTY PERCENT (20%) of the entire Contract Price, exclusive of all Recurrent Costs, shall be paid against delivery of all equipment, cables and accessories.</p> <p>(c) Custom Software and Custom Materials: NONE</p> <p>(d) Services other than Training: NONE</p> <p>(e) Training: NONE</p> <p>(f) Delivery of a fully functional Network (after testing and commissioning):</p> <p>FIFTY PERCENT (50%) of the entire Contract Price, exclusive of all Recurrent Costs, as final payment against fully functional Network.</p> <p>(g) Recurrent Costs: NONE</p> <p>TEN PERCENT (10%) of the entire Contract Price shall be retained for one year (1) as follows:</p> <p>FIVE PERCENT (5%) for six (6) months</p> <p>FIVE PERCENT (5%) for a further six (6) months</p>
GCC 12.1	<p>LOT 2</p> <p>(a) Advance Payment</p> <p>TWENTY PERCENT (20%) of the entire Contract Price, exclusive of all Recurrent Costs, shall be paid against receipt of a</p>

	<p>claim accompanied by the Advance Payment Security specified in GCC Clause 13.2.</p> <p>(b) THIRTY PERCENT (30%) of the entire Contract Price, exclusive of all Recurrent Costs, shall be paid against delivery of all hardware, software and licenses.</p> <p>(c) Custom Software and Custom Materials: NONE</p> <p>(d) Services other than Training: NONE</p> <p>(e) Training: APPLICABLE FOR LOT 2</p> <p>(f) Delivery of an Enterprise Network Management and WAN Optimisation Solution</p> <p>FOURTY PERCENT (40%) of the entire Contract Price, exclusive of all Recurrent Costs, as final payment against a fully functional Enterprise Network Management and WAN Optimization Solution and delivery of training on the system operations.</p> <p>(g) Recurrent Costs: NONE</p> <p>TEN PERCENT (10%) of the entire Contract Price shall be retained for one year (1) as follows:</p> <p>FIVE PERCENT (5%) for six (6) months</p> <p>FIVE PERCENT (5%) for a further six (6) months</p>
GCC 12.3	<p>The Purchaser shall pay to the Supplier interest on the delayed payments at a rate of:</p> <p>LIBOR PLUS 2% FOR FOREIGN PORTION and</p> <p>CBK LENDING INTEREST RATE PLUS 2% FOR LOCAL PORTION OF DELAYED PAYMENTS BOTH AT THREE MONTHS MATURITY PERIOD.</p>
GCC 12.4	<p>For Goods and Services supplied locally, the Purchaser will pay the Supplier IN THE CURRENCY STATED IN THE CONTRACT AGREEMENT AND THE PRICE SCHEDULES.</p> <p>The Supplier will invoice the Purchaser in the currency used in the Contract Agreement.</p>

GCC 12.5	Payment for Goods supplied from outside the Purchaser's Country shall be in the form of: NOT APPLICABLE.
----------	---

13. Securities (GCC Clause 13)

GCC 13.2.1	The Supplier shall provide within twenty-eight (28) days of the notification of Contract award an Advance Payment Security in the amount and currency of the Advance Payment specified in SCC for GCC Clause 12.1 above.
GCC 13.2.2	The reduction in value and expiration of the Advance Payment Security: NOT APPLICABLE.
GCC 13.3.1	The Performance Security shall be denominated IN THE CURRENCY OF THE CONTRACT.
GCC 13.3.4	During the Warranty Period (i.e., after Operational Acceptance of the System), the Performance Security shall be reduced to ZERO (0%) percent of the Contract Price, excluding any Recurrent Costs.

14. Taxes and Duties (GCC Clause 14)

GCC 14	THERE ARE NO SPECIAL CONDITIONS OF CONTRACT APPLICABLE TO GCC CLAUSE 14.
--------	---

D. INTELLECTUAL PROPERTY

15. Copyright (GCC Clause 15)

GCC 15.3	The Purchaser may assign, license, or otherwise voluntarily transfer its contractual rights to use the Standard Software or elements of the Standard Software, without the Supplier's prior written consent, under the following circumstances: NONE.
GCC 15.4	<p>The Purchaser's and Supplier's rights and obligations with respect to Custom Software or elements of the Custom Software are as follows: ACCORDING TO THE CLIENT COUNTRY'S COPYRIGHT LAW.</p> <p>The Purchaser's and Supplier's rights and obligations with respect to Custom Materials or elements of the Custom Materials are as</p>

	follows: ACCORDING TO THE CLIENT COUNTRY'S LAW.
GCC 15.5	NO SOFTWARE ESCROW CONTRACT IS REQUIRED FOR THE EXECUTION OF THE CONTRACT.

17. Confidential Information (GCC Clause 17)

GCC 17.1	THERE ARE NO MODIFICATIONS TO THE CONFIDENTIALITY TERMS EXPRESSED IN GCC CLAUSE 17.1.
GCC 17.7	The provisions of this GCC Clause 17 shall survive the termination, for whatever reason, of the Contract for THE PERIOD SPECIFIED IN THE GCC.

E. SUPPLY, INSTALLATION, TESTING, COMMISSIONING, AND ACCEPTANCE OF THE SYSTEM

18. Representatives (GCC Clause 18)

GCC 18.1	The Purchaser's Project Manager shall have the following additional powers and / or limitations to his or her authority to represent the Purchaser in matters relating to the Contract: NO ADDITIONAL POWERS OR LIMITATIONS.
GCC 18.2.2	The Supplier's Representative shall have the following additional powers and / or limitations to his or her authority to represent the Supplier in matters relating to the Contract: NO ADDITIONAL POWERS OR LIMITATIONS.

19. Project Plan (GCC Clause 19)

GCC 19.1	<p>Chapters in the Project Plan for both lots shall address the following subject:</p> <ul style="list-style-type: none"> (a) Project Organization and Management Plan; (b) Delivery and Installation and Configuration Plan (c) Training Plan (for Lot 2 only) (d) Pre-commissioning and Operational Acceptance Testing Plan (e) Warranty Service Plan (f) Task, Time, and Resource Schedules (g) Post-Warranty Service Plan (where applicable) (h) Technical Support Plan (where applicable)
GCC 19.2	<p>The Purchaser shall, within FOURTEEN (14) days of issue of the Notification of Award, notify the Supplier of any respects in which it considers that the Project Plan does not adequately ensure that the proposed program of work, proposed methods, and/or proposed Information Technologies will satisfy the Technical Requirements and/or the SCC (in this Clause 19.2 called “non-conformities” below). The Supplier shall, within SEVEN (7) days of receipt of such notification, correct the Project Plan and resubmit to the Purchaser. The Purchaser shall, within SEVEN (7) days of resubmission of the Project Plan, notify the Supplier of any remaining non-conformities. This procedure shall be repeated as necessary until the Project Plan is free from non-conformities. When the Project Plan is free from non-conformities, the Purchaser shall provide confirmation in writing to the Supplier. This approved Project Plan (“the Agreed and Finalized Project Plan”) shall be contractually binding on the Purchaser and the Supplier.</p>
GCC 19.5	<p>The Supplier shall submit to the Purchaser the following reports:</p> <ul style="list-style-type: none"> (a) Monthly (Quarterly) progress reports, summarizing: <ul style="list-style-type: none"> (i) Results accomplished during the prior period;

	<ul style="list-style-type: none"> (ii) Cumulative deviations to date from schedule of progress milestones as specified in the Agreed and Finalized Project Plan; (iii) Corrective actions to be taken to return to planned schedule of progress; proposed revisions to planned schedule; (iv) Other issues and outstanding problems; proposed actions to be taken; (v) Resources that the Supplier expects to be provided by the Purchaser and/or actions to be taken by the Purchaser in the next reporting period; (vi) Other issues or potential problems the Supplier foresees that could impact on project progress and/or effectiveness.
--	---

20. Subcontracting (GCC Clause 20)

GCC 20	Sub-contracting is NOT allowed.
--------	--

21. Design and Engineering (GCC Clause 21)

GCC 21.2	The Contract shall be executed in accordance with the edition or the revised version of all referenced codes and standards current TWENTY EIGHT (28) days before bid submission.
GCC 21.3.1	<p>The Supplier shall prepare and furnish to the Project Manager the following documents for which the Supplier must obtain the Project Manager's approval before proceeding with work on the System or any Subsystem covered by the documents.</p> <ul style="list-style-type: none"> (1) Detailed Site Surveys Report (for Lot 1 only) (2) Network Schematic Diagrams (3) Final Subsystem Configurations

22. Procurement, Delivery, and Transport (GCC Clause 22)

GCC 22.4.3	The Supplier SHALL be free to use transportation through carriers registered in any eligible country and SHALL obtain insurance from any eligible source country.
------------	---

GCC 22.5	The Supplier shall provide the Purchaser with shipping and other documents AS SPECIFIED IN THE GCC.
----------	--

23. Product Upgrades (GCC Clause 23)

GCC 23.4	The Supplier shall provide the Purchaser: WITH ALL NEW VERSIONS, RELEASES, AND UPDATES TO ALL STANDARD EQUIPMENT DURING THE WARRANTY PERIOD, FOR FREE, AS SPECIFIED IN THE GCC.
----------	--

24. Implementation, Installation, and Other Services (GCC Clause 24)

GCC 24	THERE ARE NO SPECIAL CONDITIONS OF CONTRACT APPLICABLE TO GCC CLAUSE 24.
--------	---

25. Inspections and Tests (GCC Clause 25)

GCC 25	THERE ARE NO SPECIAL CONDITIONS OF CONTRACT APPLICABLE TO GCC CLAUSE 25.
--------	---

26. Installation of the System (GCC Clause 26)

GCC 26	THERE ARE NO SPECIAL CONDITIONS OF CONTRACT APPLICABLE TO GCC CLAUSE 26.
--------	---

27. Commissioning and Operational Acceptance (GCC Clause 27)

GCC 27.2.1	Operational Acceptance Testing shall be conducted in accordance with SYSTEM OR THE SUBSYSTEMS, THE TESTS, THE TEST PROCEDURES, AND THE REQUIRED RESULTS FOR ACCEPTANCE.
GCC 27.2.2	If the Operational Acceptance Test of the System, or Subsystem(s), cannot be successfully completed within NO MORE THAN THIRTY (30) days from the date of Installation or any other period agreed upon by the Purchaser and the Supplier, then GCC Clause 27.3.5 (a) or (b) shall apply, as the circumstances may dictate.

F. GUARANTEES AND LIABILITIES

28. Operational Acceptance Time Guarantee (GCC Clause 28)

GCC 28.2	Liquidated damages shall be assessed at ONE HALF OF ONE PERCENT (0.5%) of Contract Price per week. The maximum liquidated damages is TEN PERCENT (10%) of the Contract Price, or relevant part of the Contract Price if the liquidated damages apply to a Subsystem.
GCC 28.3	Liquidated damages shall be assessed ONLY WITH RESPECT TO ACHIEVING OPERATIONAL ACCEPTANCE.

29. Defect Liability (GCC Clause 29)

GCC 29.1	For Software, exceptions or limitations to the Supplier's warranty obligations shall be as follows: NONE.
GCC 29.3 (iii)	The Supplier warrants that the following items have been released to the market for the following specific minimum time periods: NO SPECIFIC MINIMUM TIME REQUIREMENTS ARE ESTABLISHED FOR THIS CONTRACT OTHER THAN THAT THE INFORMATION TECHNOLOGIES MUST HAVE BEEN PREVIOUSLY RELEASED TO THE MARKET.
GCC 29.4	The Warranty Period (N) shall begin from the date of Operational Acceptance of the System or Subsystem and extend for: TWELVE (12) MONTHS FOR BOTH THE HARDWARE AND SOFTWARE.
GCC 29.10	During the Warranty Period, the Supplier must commence the work necessary to remedy defects or damage within FOURTEEN (14) DAYS OF NOTIFICATION.

30. Functional Guarantees (GCC Clause 30)

GCC 30	THERE ARE NO SPECIAL CONDITIONS OF CONTRACT APPLICABLE TO GCC CLAUSE 30.
--------	---

31. Intellectual Property Rights Warranty (GCC Clause 31)

GCC 31	THERE ARE NO SPECIAL CONDITIONS OF CONTRACT APPLICABLE TO GCC CLAUSE 31.
--------	---

32. Intellectual Property Rights Indemnity (GCC Clause 32)

GCC 32	THERE ARE NO SPECIAL CONDITIONS OF CONTRACT APPLICABLE TO GCC CLAUSE 32.
--------	---

33. Limitation of Liability (GCC Clause 33)

GCC 33	THERE ARE NO SPECIAL CONDITIONS OF CONTRACT APPLICABLE TO GCC CLAUSE 33.
--------	---

G. RISK DISTRIBUTION

34. Transfer of Ownership (GCC Clause 34)

GCC 34	THERE ARE NO SPECIAL CONDITIONS OF CONTRACT APPLICABLE TO GCC CLAUSE 34.
--------	---

35. Care of the System (GCC Clause 35)

GCC 35	THERE ARE NO SPECIAL CONDITIONS OF CONTRACT APPLICABLE TO GCC CLAUSE 35.
--------	---

36. Loss of or Damage to Property; Accident or Injury to Workers; Indemnification (GCC Clause 36)

GCC 36	THERE ARE NO SPECIAL CONDITIONS OF CONTRACT APPLICABLE TO GCC CLAUSE 36.
--------	---

37. Insurances (GCC Clause 37)

GCC 37.1 (c)	The Supplier shall obtain Third-Party Liability Insurance in the amount of FIVE PERCENT (5%) . The Insurance shall cover the period from BEGINNING DATE, RELATIVE TO THE EFFECTIVE DATE OF THE CONTRACT until EXPIRATION DATE, RELATIVE TO THE EFFECTIVE DATE OF THE CONTRACT OR ITS COMPLETION.
GCC 37.1 (e)	THERE ARE NO SPECIAL CONDITIONS OF CONTRACT APPLICABLE TO GCC CLAUSE 37.

38. Force Majeure (GCC Clause 38)

GCC 38	THERE ARE NO SPECIAL CONDITIONS OF CONTRACT APPLICABLE TO GCC CLAUSE 38.
--------	---

H. CHANGE IN CONTRACT ELEMENTS

39. Changes to the System (GCC Clause 39)

GCC 39	THERE ARE NO SPECIAL CONDITIONS OF CONTRACT APPLICABLE TO GCC CLAUSE 39.
--------	---

40. Extension of Time for Achieving Operational Acceptance (GCC Clause 40)

GCC 40	THERE ARE NO SPECIAL CONDITIONS OF CONTRACT APPLICABLE TO GCC CLAUSE 40.
--------	---

41. Termination (GCC Clause 41)

GCC 41	THERE ARE NO SPECIAL CONDITIONS OF CONTRACT APPLICABLE TO GCC CLAUSE 41.
--------	---

42. Assignment (GCC Clause 42)

GCC 42	THERE ARE NO SPECIAL CONDITIONS OF CONTRACT APPLICABLE TO GCC CLAUSE 42.
--------	---

SECTION VI. TECHNICAL REQUIREMENTS (INCLUDING IMPLEMENTATION SCHEDULE)

Table of Contents: Technical Requirements

A. Background.....	147
0.1 The Purchaser.....	147
0.2 Acronyms Used in These Technical Requirements	147
B. Business Function and Performance Requirements	152
C. Implementation Schedule	209
Implementation Schedule Table	211
Attachment 1: Site Drawings and Site Survey Information.....	212

Technical Requirements

A. BACKGROUND

0.1 The Purchaser

0.1.1 Kenya Revenue Authority (KRA) is an agency of the government of Kenya that is responsible for the assessment, collection and accounting for of all revenues that are due to government, in accordance with the laws of Kenya. KRA with the support of World Bank intends to improve the ICT Network at the Port of Kilindini. This being a critical ICT network asset supporting strategic business operations, KRA intends to partner with leading OEM(s) to deliver a high performance, reliable and manageable Network Infrastructure. The OEM(s) will be responsible for supporting implementation of the various components supplied under this tender.

KRA preference therefore is to partner with OEM(s) in implementing a suitable solution to meet its objectives. In this regard the OEM will take the lead role in implementing the solution. Bidders must therefore demonstrate and provide proof of the commitment of the OEM in supporting the solution and providing implementation services

Bidders must therefore demonstrate and provide proof for this arrangement.

0.2 Acronyms Used in These Technical Requirements

0.2.1

	Term	Explanation
	bps	bits per second
	Ethernet	IEEE 802.3 Standard LAN protocol
	GB	gigabyte
	Hz	Hertz (cycles per second)
	IEEE	Institute of Electrical and Electronics Engineers
	ISO	International Standards Organization
	KB	kilobyte
	LAN	Local area network
	MAN	Metropolitan Area Network
	MB	megabyte
	OS	Operating system
	RAM	Random access memory

	Term	Explanation
	RISC	Reduced instruction-set computer
	TCP/IP	Transmission Control Protocol / Internet Protocol
	SD	Software Defined
	SDWAN	Software Defined Wide Area Network
	V	Volt
	WLAN	Wireless LAN

Schedules

LOT 1: DESIGN, SUPPLY, INSTALLATION, CONFIGURATION AND COMMISSIONING OF A FIBER OPTIC BASED METROPOLITAN AREA NETWORK (MAN) AND LOCAL AREA NETWORKS (LANs).

NOTES:

1. Bidders are advised to ensure that the final Bill of Quantities (BoQ) submitted conforms to the format and quantities provided under the table below, except for items marked as estimates (*) where quantities will be determined during a MANDATORY site survey.

2. Work must be completed and commissioned within TEN (10) Months of Signing Contract

	Fiber and LAN Deployment	Estimated Quantities
	Description	Quantity
1	Work Area subsystem	
(a)	Cat 6a Dual Modules and outlet	400
(b)	Cat 6a patch cords 5 meters	800
2	Horizontal subsystem	
(a)	Cat 6a cable	150 Rolls (Standard 305 meters)
(b)	Cat 6a Outdoor UTP cable	20 Rolls (Standard 305 meters)
3	Pathway subsystem	
(a)	Heavy Duty Outdoor PVC Conduits	*
(b)	250mm by 50mm metal trunking	*
4	Back bone subsystem	
(a)	24 Core Armored Single-Mode Fiber optic (outdoor)	*
(b)	16 Core Armored Single-Mode Fiber optic (outdoor)	*
(c)	16 Core Multi-Mode Fiber optic (indoor)	*
5	Administration subsystem	
(a)	Cat6a 48 port patch panel	10
(b)	Cat6a 24 port patch panel	12
(c)	Cat6a 12 port patch panel	12
(d)	Fiber 12 way patch panel	65
(e)	Cat6a 1meter patch cord	800
(f)	Fiber patch cord 10meter	20
(g)	Fiber patch cord 3meter	30
(h)	Accessories e.g. Wall Clips, Pigtails etc.	*
(i)	Fiber patch cord 1meter	140
(j)	Cable manager	45

(k)	42u cabinets (Free standing)	5
(l)	32u cabinets (Free standing)	15
(m)	15u cabinets (Wall Mount)	10
(n)	1500 VA Rack Mountable UPS	30
6	Active devices	
(a)	48 Port Switch	15
(b)	24 Port Switch	25
(c)	24 Port Fiber Switch	10
(d)	Branch Router	30
(e)	Data Centre SDWAN Controller and licenses	In HA
(f)	Single-Mode SFP Fiber Modules	120
(g)	Multi-Mode SFP Fiber Modules	30
7	Professional services	
(a)	Laying of metal trunking	1
(b)	Labor Pulling and termination of Cat6a cables	1
(c)	Labor pulling and termination of fiber cables	1
(d)	Testing and documentation	1
(e)	Civil works	1

Note: For items marked *, the specific quantities required are to be established during the bidders' mandatory site survey visit.

LOT 2: DESIGN, SUPPLY, INSTALLATION AND CONFIGURATION OF AN ENTERPRISE NETWORK MANAGEMENT AND WAN OPTIMISATION SOLUTION.

NOTES:

1. Bidders are advised to ensure that the Bill of Quantities (BoQ) submitted conforms to the format and quantities provided in the table below.
2. The point of delivery for this Lot is at two (2) KRA Data Centers in Nairobi and Ten (10) other selected Branch offices

	Item/Description	Quantity
1	Overall design of an enterprise Network Management and WAN optimization Solution	1
2	Supply, Installation and Configuration of a WAN Optimization Solution for Two(2) Data Centers (Hardware and software)	2
3	Supply, Installation and Configuration of a WAN optimization Solution for Ten(10) medium Branch Station (Hardware and software)	10
4	Supply, Installation and Configuration of a centralized management solution (for items 1,2,3 above) at the Data centers (Hardware and software)	2
5	Installation, Configuration, integration and user training for the overall solution	1

B. BUSINESS FUNCTION AND PERFORMANCE REQUIREMENTS

LOT 1: DESIGN, SUPPLY, INSTALLATION, CONFIGURATION AND COMMISSIONING OF A FIBER OPTIC BASED METROPOLITAN AREA NETWORK (MAN) AND LOCAL AREA NETWORKS (LAN) EQUIPMENT AND ACCESSORIES.

1. TECHNICAL SPECIFICATIONS AND REQUIREMENTS FOR EQUIPMENT (AND SOFTWARE), CABLES AND ACCESSORIES.

INSTRUCTIONS TO BIDDERS:

- Bidders **SHALL** provide a detailed and substantive response/ proposal to the stated requirement, regardless of any technical data sheets/brochures/documentation attached.
- Use of **YES, NO, TICKS, COMPLIANT** etc. without providing a detailed and substantive response will be considered **NON-RESPONSIVE** and may lead to disqualification.
- Equipment whose manufacturer has already announced the end of production, sales or support **SHALL** not be accepted.
- All UTP Cable, Fiber optic Cable, Data Outlets and Patch Panels used in the project **MUST** be of a similar Brand/Manufacturer (must be specified) for uniformity and seamless integration.
- Failure to meet the minimum technical requirements/specifications in **FUNDAMENTAL** clauses automatically renders the item/bid **NON-RESPONSIVE**.
- Bidders **SHALL** stamp and sign any attached Technical data sheets.

1. Minimum Technical Specifications for 48 Port Switches

	Feature	Minimum Specification	Bidder's Response	Remark
1	General Descriptive Requirement	Enterprise switching access platform, configurable to provide security, mobility, and cloud. Must provide Software Defined Access Functionality at no additional subscription. The switch must integrate seamlessly to the existing KRA network.		Fundamental
2	Model and Technology	Must be an internationally recognized brand, consistently placed in the leadership quadrant of Gartner report for the last three (3) years in its product/market category. Bidder must specify Type, Brand, series etc., up to the specific device details.		Fundamental
3	Manufacturer Support and Warranty	Minimum 2 years on Parts, Labour and software. Equipment must include the manufacturer's premier technical support services. Bidder must provide a letter from the manufacturer committing him to support equipment and services supplied under this tender.		Fundamental
4	Network Ports	48 PoE+ Ethernet 10/100/1000 ports, 4 - SFP transceiver-based uplink ports.		Fundamental
5	Stacking Bandwidth	Upto 480 Gbps		Fundamental
6	Hardware Configuration	Minimum 1.8 GHZ processor,8GB SDRAM and 16 GB Internal memory		Fundamental
7	Network Monitoring and security	Compliant with IEEE SNMP standards. Capable of monitoring the Network up to Node Level. Security features must include Encrypted Traffic Analytics.		Fundamental
8	Warranty and Support	Minimum 2 years on Parts, Labour and software. In addition, the equipment must include the manufacturer's premier technical support services that include: Hardware replacement options, Operating system updates, access to Manufacturer's technical assistance team, Online troubleshooting /support tools and proactive problem diagnosis services.		Fundamental

2. Minimum Technical Specifications for 24 Port Switches

	Feature	Minimum Specification	Bidder's Response	Remark
1	General Descriptive Requirement	Enterprise switching access platform, configurable to provide security, mobility, and cloud. Must provide Software Defined Access Functionality at no additional subscription. The switch must integrate seamlessly to the existing KRA network.		Fundamental
2	Model and Technology	Must be an internationally recognized brand, consistently placed in the leadership quadrant of Gartner report for the last three (3) years in its product/market category. Bidder must specify Type, Brand, series etc., up to the specific device details.		Fundamental
3	Manufacturer Support and Warranty	Minimum 2 years on Parts, Labour and software. Equipment must include the manufacturer's premier technical support services. Bidder must provide a letter from the manufacturer committing him to support equipment and services supplied under this tender.		Fundamental
4	Network Ports	24 PoE+ Ethernet 10/100/1000 ports, 4 - SFP transceiver-based uplink ports.		Fundamental
5	Stacking Bandwidth	Upto 480 Gbps		Fundamental
6	Hardware Configuration	Minimum 1.8 GHZ processor(or equivalent),8GB SDRAM and 16 GB Internal memory		Fundamental
7	Network Monitoring and security	Compliant with IEEE SNMP standards. Capable of monitoring the Network up to Node Level. Security features must include Encrypted Traffic Analytics.		Fundamental
8	Warranty and Support	Minimum 2 years on Parts, Labour and software. In addition, the equipment must include the manufacturer's premier technical support services that include: Hardware replacement options, Operating system updates, access to Manufacturer's		Fundamental

		technical assistance team, Online troubleshooting /support tools and proactive problem diagnosis services.		
--	--	--	--	--

3. Minimum Technical Specifications for 24 Port Fiber Switches

	Feature	Minimum Specification	Bidder's Response	Remark
1.	General Descriptive Requirement	<p>Must be Enterprise-class core and aggregation layer switch, configurable for Security and cloud.</p> <p>Must provide Software Defined Access functionality.</p> <p>The switch must integrate seamlessly to the existing KRA network.</p> <p>Integrated Services Router (ISR) that delivers highly secure data, voice, video, and application service</p>		Fundamental
2.	Model and Technology	<p>Must be an internationally recognized brand, consistently placed in the leadership quadrant of Gartner report for the last three (3) years in its product/market category.</p> <p>Bidder must specify Type, Brand, series etc., up to the specific device details</p>		Fundamental
3.	Manufacturer Support and Warranty	<p>Minimum 2 years on Parts, Labour and software. Equipment must include the manufacturer's premier technical support services.</p> <p>Bidder must provide a letter from the manufacturer committing him to support equipment and services supplied under this tender.</p>		Fundamental
4.	Network Ports	Minimum 24x 1/10/25G Gigabit SFP Ethernet + 4x 40/100G Uplink		Fundamental
5.	Routing and Layer 3 Features	Must support Advanced Layer 3 switching (IPv4 and IPv6) features, advanced quality of service (QoS), rate limiting, Access Control Lists (ACLs) and Interior Gateway Routing Protocol (IGRP) and OSPF/		Fundamental

6.	Hardware Configuration	Minimum 4-core x86, 2.4-GHz CPU (or equivalent) ,Minimum 16 GB DRAM,16 GB Flash		Fundamental
7.	Security	Port Level Security e.g. Port Filtering, Access Control Lists, Policy based routing etc. Management by a recognized proprietary operating system/		Fundamental
8.	Warranty and Support	<p>Minimum 2 years on Parts, Labour and software.</p> <p>In addition, the equipment must include the manufacturer’s premier technical support services that include:</p> <p>Hardware replacement options, Operating system updates, access to Manufacturer’s technical assistance team, Online troubleshooting /support tools and proactive problem diagnosis services.</p>		Fundamental

4. Minimum Technical Specification for Branch Routers

	Features	Minimum Requirements	Bidder’s Response	Remark
1.	General Descriptive Requirement	Branch Router that delivers Integrated Services, highly secure data, voice, video and application service. Must support Software Defined Access features		Fundamental
2.	Model/Brand	<p>Must be an internationally recognized brand, consistently placed in the leadership quadrant of Gartner report for the last three (3) years in its product/market category.</p> <p>Bidder must specify Type, Brand, series etc., up to the specific device details.</p>		Fundamental
3.	Manufacturer Support and Warranty	<p>Minimum 2 years on Parts, Labour and software. Equipment must include the manufacturer’s premier technical support services.</p> <p>Bidder must provide a letter from the manufacturer committing him to support equipment and services supplied under this tender.</p>		Fundamental
4.	SDWAN Support	Must provide Software Defined WAN (SDWAN) software features and a converged branch infrastructure.		Fundamental
5.	Performance and Throughput	<p>Up to 2-Gbps+ performance.</p> <p>Encrypted throughput of upto 500 Mbps</p>		Fundamental

Section VII – Works Requirements 2-157

	Features	Minimum Requirements	Bidder's Response	Remark
6.	Memory and Processor	High-performance multi-core processors that supports high-speed WAN and multiple concurrent services. DRAM: Minimum 4GB, expandable to at least 16GB External: Minimum 4GB, expandable to at least 16GB		Fundamental
7.	Integrated WAN Ports	Minimum Two (2) PoE GE / SFP Preinstalled		Fundamental
8.	Software IOS release	Must be delivered with the latest version and supported OS release running. Capable of supporting Gigabit Ethernet .The provided OS must be installed with the initial product activated license that supports advanced IP services i.e. Data, Communications and Security		Fundamental
9	Warranty and Support	Minimum 2 years on Parts, Labour and software. In addition, the equipment must include the manufacturer's premier technical support services that include: Hardware replacement options, Operating system updates, Access to Manufacturer's technical assistance team, Online troubleshooting / support tools and proactive problem diagnosis services.		Fundamental

5. Minimum Technical Specification for Data Centre SDWAN Controller

	Features	Minimum Requirements	Bidder's Response	Remark
1	General Descriptive Requirement	Hardware and Software MUST be purposed build and designed for Software Defined (SD) architecture and Enterprise Network Functions Virtualization at the Data Centre. Capable of supporting aggregation of standard Branch SDWAN operations. The device MUST integrate seamlessly with KRA existing infrastructure as is.		Fundamental

	Features	Minimum Requirements	Bidder's Response	Remark
2	Model/Brand	<p>Must be an internationally recognized brand, consistently placed in the leadership quadrant of Gartner report for the last three (3) years in its product/market category.</p> <p>Bidder must specify Type, Brand, series etc., up to the specific device details.</p>		Fundamental
3	Manufacturer Support and Warranty	<p>Minimum 2 years on Parts, Labour and software. Equipment must include the manufacturer's premier technical support services.</p> <p>Bidder must provide a letter from the manufacturer committing him to support equipment and services supplied under this tender.</p>		Fundamental
4	Power	Must Support both AC and PoE Power		Fundamental
5	Network Ports	Must have at least 2 Gigabit Ethernet (GE) WAN Ports plus additional built-in minimum 8-port GE PoE capable LAN switch		Fundamental
6	Hardware	<p>Processor: Intel Based Processor</p> <p>DRAM: Minimum 16 GB must be installed.</p>		Fundamental
7	Software and security	<p>Must include a centralized network management system that provides a GUI interface to monitor, configure and maintain devices on the Network, control the flow of data traffic in the network and authenticate devices as they join the network.</p> <p>Must support Zero Touch Provisioning of all CPE devices.</p>		Fundamental
8	Licensing	The controller MUST be supplied with the all the requisite licenses to support SD-WAN features for at least 5 years.		Fundamental
9	Installation and Configuration	Bidder must install and configure both hardware and software so as to function as an enterprise SDWAN solution		Fundamental
10	Warranty and Support	<p>Minimum 2 years on Parts, Labour and software.</p> <p>In addition, the equipment must include the manufacturer's premier technical support services that include:</p> <p>Hardware replacement options, Operating system updates, Access to Manufacturer's technical assistance team, Online</p>		Fundamental

	Features	Minimum Requirements	Bidder's Response	Remark
		troubleshooting / support tools and proactive problem diagnosis services.		

6. Minimum Technical Specifications for Patch Panels

	Feature	Minimum Requirements	Bidder's Response	Remark
1.	Brand	Must be an internationally recognized brand, consistently placed in the leadership quadrant of Gartner report for the last three (3) years in its product/market category. Must be same brand as the proposed UTP Cable, Fiber optic Cable and Data Outlets for uniformity and seamless integration. (bidder must specify brand)		Fundamental
1.	Category	Minimum 6a UTP		Fundamental
2.	Port Density	State port density		
3.	Cable Management	Rear Cable management bar installed		
4.	Labels	Printable labels must be available		
5.	Wiring	T568A/T568B compliant and easy to read		Fundamental
6.	Contact materials	Plated phosphor bronze, stainless steel		
7.	Mounting	CEA-310-E 19-inch (482.6 mm) rack		
8.	Current rating	1.5 A		
9.	Contact resistance	20 m Ω		
10.	Insulation resistance	500 M Ω		
11.	Panel material	18 gauge cold rolled steel, black e-coated		Fundamental
12.	Compatibility	CAT6a downward compatible with CAT5e/CAT5		Fundamental

7. Minimum Technical Specifications for UTP Ethernet Cable

	Feature	Minimum Requirements	Bidder's Response	Remark
1.	Brand	<p>Must be an internationally recognized brand, consistently placed in the leadership quadrant of Gartner report for the last three (3) years in its product/market category.</p> <p>Must be same brand as the proposed Fiber optic Cable, Data Outlets and Patch Panels for uniformity and seamless integration. (bidder must specify brand)</p>		
2.	Category	Minimum 6a UTP		Fundamental
3.	Size	4-Pair solid, Gauge: 23 AWG		Fundamental
4.	Operating frequency	500 MHZ		
5.	Standards	TIA/EIA 568 A/B, ISO/IEC 11801		Fundamental

8. Minimum Technical Specifications for Data Outlets

	Feature	Minimum Requirements	Bidder's Response	Remark
1.	Brand	<p>Must be an internationally recognized brand, consistently placed in the leadership quadrant of Gartner report for the last three (3) years in its product/market category.</p> <p>Must be Same brand as the proposed UTP Cable, Fiber optic Cable, and Patch Panels for uniformity and seamless integration. (bidder must specify brand)</p>		
2.	Assembly	Cat 6 double angled RJ45 outlet modules installed on Single gang face plates		Fundamental
3.	Contact resistance	20 mΩ		
4.	Insulation Resistance	500 MΩ		
5.	Current rating	1.5 A PoE , PoE+		
6.	Contact Materials	Plated phospher bronze, stainless steel		
7.	Plug compatibility	<p>Compatible with RJ45 (8-position) plugs</p> <p>Should also be backward compatible to cat 5e</p>		Fundamental

9. Minimum Technical Specifications for Ethernet Patch cords

	Feature	Minimum Requirements	Bidder's Response	Remark
1.	Brand	<p>Must be an internationally recognized brand, consistently placed in the leadership quadrant of Gartner report for the last three (3) years in its product/market category.</p> <p>Must be same brand as the proposed UTP Cable, Fiber optic Cable, Data Outlets and Patch Panels for uniformity and seamless integration(bidder must specify brand)</p>		Fundamental
2.	Category	Minimum 6a 4-pair Ethernet cable		Fundamental
3.	Length	5 M and 1 M		Fundamental
4.	Boot Color	With colour matching jacket/ boot to labelling on the faceplates		Fundamental

10. Minimum Technical Specifications for Trunking

	Feature	Minimum Requirements	Bidder's Response	Remark
1.	Material	Metal trunking for permanent wall structures		Fundamental
2.	Size	Metal trunking (6" by 2"), 250mm by 50mm two compartment.		Fundamental
3.	Gauge	Heavy duty		Fundamental

11. Minimum Technical Specifications for 42/32/15 U Data Cabinet

	Feature	Minimum Requirements	Bidder's Response	Remark
1.	Brand	Must be an internationally recognized brand, consistently placed in the leadership quadrant of Gartner report for the last three (3) years in its product/market category. Must be same brand as the proposed UTP cable for uniformity and seamless integration(bidder must specify brand)		
2.	Form Factor	42/32 U free standing standard data cabinet.15 U wall mounted		Fundamental
3.	Construction	Front door: with glass window Rear door: high-flow mesh Both doors keyed locks for security Heavy duty solid sides Installed axial fan kits		Fundamental
4.	Power outlets in the cabinet	6-Way universal PDU 3A/220 - 240 V AC earthed and fused with shutters		Fundamental
5.	Cable manager	Installed with cable manager for both horizontal/backbone cabling and patch cords		Fundamental

12. Minimum Technical Specifications for Single-Mode Outdoor Armored Fiber Cable

	Feature	Minimum Requirements	Bidder's Response	Remark
1.	Brand	Must be an internationally recognized brand, consistently placed in the leadership quadrant of Gartner report for the last three (3) years in its product/market category. Must be same brand as the proposed UTP Cable, Data Outlets and Patch Panels for uniformity and seamless integration. (bidder must specify brand)		Fundamental
2.	Jacket characteristics and Material	Water Blocking Aramid Yarn Armored PVC		Fundamental
3.	Attenuation (Max)	3.50 dB/km @ 850nm		Fundamental
4.	Standards	Optical and mechanical performance: IEC 60794-2, IEC 60794-2-20, ISO 11801, EN 50173-1		Fundamental

13. Minimum Technical Specifications for Fiber Patch cords

	Feature	Minimum Requirements	Bidder's Response	Remark
1.	Brand	Must be an internationally recognized brand, consistently placed in the leadership quadrant of Gartner report for the last three (3) years in its product/market category. Must be same brand as the proposed UTP Cable, Fiber optic Cable, Data Outlets and Patch Panels for uniformity and seamless integration. (bidder must specify brand)		Fundamental
2.	Compatibility	Must be compatible with the supplied fiber ports on the access switches and Fiber patch panels.		Fundamental
3.	Category	Must support either LC or SC whichever is compatible with the supplied uplink fiber switch port.		Fundamental
4.	Length	Minimum 3 m		Fundamental

14. Minimum Technical Specifications for SFP Transceiver Modules

	Feature	Minimum Requirements	Bidder's Response	Remark
1.	Brand	<p>Must be an internationally recognized brand, consistently placed in the leadership quadrant of Gartner report for the last three (3) years in its product/market category.</p> <p>Must be same brand as the proposed switches for uniformity and seamless integration (bidder must specify brand)</p>		Fundamental
2.	Compatibility	Must be compatible with the supplied fiber ports on the access switches and Fiber patch panels.		Fundamental
3.	Form Factor	Small pluggable form factor.		Fundamental

15. Minimum Technical Specifications for Fiber Patch Panel

	Feature	Minimum Requirements	Bidder's Response	Remark
1.	Brand	<p>Must be an internationally recognized brand, consistently placed in the leadership quadrant of Gartner report for the last three (3) years in its product/market category.</p> <p>Must be Same brand as the UTP Cable, Fiber optic Cable, Data Outlets and Patch Panels for uniformity and seamless integration. (bidder must specify brand)</p>		Fundamental
2.	Compatibility	<p>Universal compatibility.</p> <p>Must be compatible with the supplied backbone fiber.</p>		Fundamental
3.	Form Factor	1HU		
4.	Adapter Support	Must support either LC or SC whichever is compatible with the supplied uplink fiber switch port.		Fundamental

16. Minimum Technical Specifications for an Outdoor Shielded STP Ethernet Cable

	Feature	Minimum Requirements	Bidder's Response	Remark
1	Brand	Must be an internationally recognized brand, consistently placed in the leadership quadrant of Gartner report for the last three (3) years in its product/market category. Must be Same brand as the UTP Cable, Fiber optic Cable, Data Outlets and Patch Panels for uniformity and seamless integration.(Bidder must specify brand)		Fundamental
2	Category	6a Shielded STP		Fundamental
3	Size	4-Pair solid pair copper, Gauge: 23 AWG		Fundamental
4	Operating frequency	750 MHZ		
5	Material	Includes Outer Shield made of Aluminium Foil plus Mylar Water Blocking PVC with rip Cord jackets		Fundamental
6	Standards	TIA/EIA 568 A/B, ISO/IEC 11801, TIA/EIA 568-C.2		Fundamental

17. Minimum Technical Specifications for a Rack Mount UPS

	Feature	Minimum Requirements	Bidder's Response	Remark
1	Brand	Equipment must be an internationally recognized brand, consistently placed in the Gartner Magic Quadrant report for the last three (3) years in its product/market category (bidder must specify Brand,model,series etc)		Fundamental
2	Design Form Factor	Must be Rack Mounted, to fit in 15/32/42 U cabinets		Fundamental
3	Power Rating	Minimum 1500 VA		Fundamental

	Feature	Minimum Requirements	Bidder's Response	Remark
4	Diagnostic Tools	Must have elaborate diagnostic tools accessible through a well-defined operating system		
5	Warranty and Support	Minimum 2 years on Parts, Labour and software.		Fundamental

2. TECHNICAL SPECIFICATIONS AND REQUIREMENTS FOR CABLING AND WORKS FOR KILINDINI FIBER OPTIC BASED METROPOLITAN AREA NETWORK (MAN) AND LOCAL AREA NETWORKS (LANs).

INSTRUCTIONS TO BIDDERS:

- Bidders **SHALL** provide a detailed and substantive response/ proposal to the stated requirement, regardless of any technical data sheets/brochures/documentation attached.
- Use of **YES, NO, TICKS, COMPLIANT** etc. without providing a detailed and substantive response will be considered **NON-RESPONSIVE** and may lead to disqualification.
- Failure to meet the minimum technical requirements/specifications in **FUNDAMENTAL** clauses automatically renders the item/bid **NON-RESPONSIVE**
- All outdoor Fiber Optic Cable and Accessories must be branded with “Kenya Revenue Authority” name for ease of identification.
- Defect Liability Period of 12 Months from commissioning date **SHALL** apply.
- An allowance of at least 3 meters of Fiber Cable must be provisioned at every manhole to facilitate future repairs
- Bidders **SHALL** stamp and sign any attached Technical data sheets.

SUMMARY:

The enforcement of Kilindini MAN and LANs is part of Lot 1 in this tender document and encompasses the following: (Refer to ATTACHMENT 1 for Proposed Network Schematic Diagrams).

- Laying of a Fiber Optic Based Metropolitan Area Network (MAN) Backbone Fibre Cable
- New LAN Installations
- Addition of LAN Data Points on Existing LAN

The following KRA operational areas/locations areas, all located within Kilindini Port will be covered under the scope of this project:

No.	LOCATIONS/SITES IN KILINDINI
1	GATE 9/10
2	G OFFICES
3	G SECTION SCANNER OFFICE
4	MAST (MARINE OFFICE)
5	SHED 5
6	CUSTOMS WAREHOUSE
7	GATE 12/13
8	MCC
9	KAPENGURIA SCANNER ENGINEERS OFFICE
10	KAPENGURIA MOBILE SCANNER SITE OFFICE
11	KPA HQ KRA ENFORCEMENT OFFICE
12	KPA HQ SERVER ROOM
13	KPA HQ PABX ROOM
14	GATE 18 COMMUNICATION ROOM (GATE 18 CR)
15	GATE 18 MAIN OFFICE
16	GATE 20
17	FIXED SCANNER 1 (OLD)
18	FIXED SCANNER 2 (NEW)
19	RMG
20	KIPEVU CONTAINER TERMINAL (TERMINAL 2/CNT 2)
21	KIPEVU WAREHOUSE 2 (TERMINAL 2 WAREHOUSE/CNT 2 WAREHOUSE)
22	KIPEVU WELFARE BLOCK, KRA OFFICE
23	GATE 22/26

TECHNICAL REQUIREMENTS AND SPECIFICATIONS

No.	Location	Scope of Works	Description	Bidder's Response	Remark
	SECTION A	General Description	Bidders shall provide a detailed response to the general description of the scope of works. Reference the schematic diagram attached		
1		Overall Scope of Works	<p>Enforcement of Kilindini MAN and LANs will encompass mainly:</p> <ul style="list-style-type: none"> • Laying of Backbone Fibre Cable • New LAN Installations • Addition of LAN Data Points on Existing LANs <p>Implementation of the fibre optic cable layout shall be based on STAR BUS ARCHITECTURE (see schematics/layout).</p> <p>Deployment of the optic fibre cables will entail:</p> <ol style="list-style-type: none"> 1. Two (Primary and Redundant) - (2x24pair) Multi core backhaul fibre optic cables (BUS) will be to interconnect THREE aggregation sites (Points of Presence): <ul style="list-style-type: none"> I. KPA HQ ENFORCEMENT: It will serve the following sites: <ol style="list-style-type: none"> a. KPA HQ IT Room b. PABX Room c. GATE 18 d. Gate 9/10 e. Kapenguria RSO: it will serve Kapenguria Scanner Office II. GATE 18: It will serve the following sites: <ol style="list-style-type: none"> a. Gate 20 b. Fixed Scanner 2: It will serve Fixed Scanner 1 c. Rail Mounted Gates (RMG):It will interconnect Kipevu CNT2 to Gate 18 d. Kipevu CNT2: It will serve Gate 22/26, Welfare(KRA Office) and Kipevu Warehouse 2 III. Gate 9/10 It will serve the following last mile sites: <ol style="list-style-type: none"> e. Gate 12/13: it will serve MCC 		Fundamental

No.	Location	Scope of Works	Description	Bidder's Response	Remark
			<p>f. G SHED g. G SCANNER h. Shed 5: it will serve Warehouse 1 i. Marine Unit</p> <p>2. Fibre optic cable deployment (Both 16 and 24 core) is end to end (as per the fibre sketch) with no splicing except area indicated in point 3 or on the sketch. Fibre cable termination shall always be two pair on each end.</p> <p>3. Splicing of fibre optic cable pairs shall only be done in the following area: - Connecting Kepenguria Mobile Scanner Office with RSO.</p> <p>4. Civil Works will be limited to TWO sites because no ducts exist to these sites. They include: I. Fibre connectivity to Marine Office: A man hole near KEBs offices shall be used to connect to the marine office. From the man hole, a distance of 10 meters will involve removal of cabro blocks, dig a trench, lay a conduit for the fibre and return the cabro blocks back to its previous state. The rest of the distance (80 meters) to the marine office shall involve digging a trench up-to 2 feet, lay a conduit and fill back the trench (1st feet to have the warning strip). II. Fibre Connectivity to Kapenguria-Mobile Scanner Office: From the KPA perimeter wall/fence to the office (distance 40meters) will involve laying of steel conduits.</p> <p>- Works on existing LAN's will involve mainly addition of data points and replacement of the existing LAN Ethernet switches. - Optic Fibre Cable will use the existing ducts AND conduits.</p>		

No.	Location	Scope of Works	Description	Bidder's Response	Remark
	SECTION B	Detailed Description	Bidders shall provide a detailed response to the detailed description of the scope of works in this section and respond to all locations 1 through to 18. Failure to which the bids shall be declared non-responsive		Remark
1	KPA HQ ENFORCEMENT OFFICE (POP 1)	1. LAN INSTALLATION	<p>WORKS: KPA HQ ENFORCEMENT OFFICE It will involve:</p> <ul style="list-style-type: none"> - NEW installation of LAN across the Enforcement offices - The required number of Data Points is 60 <p>Termination -It will involve T568B cabling and termination of Ethernet cable on both RJ45 module and Ethernet patch panel.</p> <p>LAN Equipment's:</p> <ul style="list-style-type: none"> - 2x48 PoE+ Port Ethernet Network Switch with 4 SFP Gig Ports. - 1x1 Router - 1x42U Cabinet (incl. of Vertical AND Horizontal Cable managers) - 1x1500 VA Rack Mountable UPS <p>Accessories:</p> <ul style="list-style-type: none"> - Ethernet Patch Panel - SFP Transceiver Modules - 3 meter Fibre Patch Cords - 1 meter and 5 meter Ethernet Patch Cords - Metallic Trunking - RJ 45 Data Modules - Data Faceplates - Cat 6a UTP Ethernet Cable 		Fundamental
		2.FIBRE CONNECTION	<p>WORKS: KPA HQ ENFORCEMENT OFFICE KPA Enforcement office will be the main source of backhaul fibre cables to TWO other main sites which are GATE 9/10 AND GATE 18 and THREE other satellite sites (PABX, KPA IT ROOM AND Kapenguria RSO). Works at the Enforcement office will involve:</p> <p>>Termination of all fibre pairs from ALL satellite stations on fibre patch panels.</p> <p>Fibre Equipment's:</p> <ul style="list-style-type: none"> - Fibre Patch Panels - 2x48 Aggregation Switch - 1x42U Cabinet (incl. of Vertical AND Horizontal Cable managers) - SFP Transceiver Modules 		

No.	Location	Scope of Works	Description	Bidder's Response	Remark
			<ul style="list-style-type: none"> - 3 meter, 5 meter and 10 meter Fibre Patch Cords - 1x1500 VA Rack Mountable UPS 		
			<p>WORKS: FIBRE FROM ENFORCEMENT TO OTHER OFFICES Several armoured outdoor multicore single mode fibre optic cable shall run to Four Locations. The locations include:</p> <p style="padding-left: 20px;">1. Gate 9/10 (Approx. Distance 3km from Enforcement). Fibre cable from Enforcement to Gate 9/10 involves:</p> <ul style="list-style-type: none"> - Deployment of a TWO - 24(2x24) core/pair Outdoor Armoured Multicore Single mode Fibre Cables. - The Optic fibre cables shall run from Enforcement Office to Gate 9/10 42U. 		
			<p>Terminations</p> <ul style="list-style-type: none"> >Four pairs (two primary pair and two secondary pair) from both 24 pair fibre cables shall be terminated on both ends to serve Gate 9/10 LAN. >Each Satellite Site shall be served by two pairs of fibre strands from Enforcement to last mile site on the 16 fibre cable e.g. G Sections, Shed 5. >The 16 core fibre cable shall run from Gate 9/10 to: <ul style="list-style-type: none"> - Marine - Shed 5: It will include fibre cable pairs from Warehouse 1. - G section. - G Scanner - Gate 12/13: It will include fibre cable pairs from serve MCC 		
			<p style="padding-left: 20px;">2. GATE 18(Approx. Distance 1.5km from Enforcement). Fibre cable from Enforcement to Gate 18 involves:</p> <ul style="list-style-type: none"> - Deployment of a TWO – 24(2x24) core/pair Outdoor Armoured Multicore Single mode Fibre Cables. - Four pairs (two primary and two secondary pairs) from both 24 pair fibre cables shall be terminated on both ends to serve Gate 18 LAN. - The Optic fibre cables shall run from Enforcement Office to GATE 18 42U Cabinet (Approx. Distance 1.5km). >16 core fibre optic cable shall run from Gate 18 to satellite stations indicated below: 		

No.	Location	Scope of Works	Description	Bidder's Response	Remark
			<p>-Gate 20, -Fixed Scanner I: It will include fibre cable pairs from New Fixed Scanner II. -RMG:It will interconnect fibre cables from Kipevu CNT2 and Gate 18. -Kipevu CNT2. It will include fibre cable pairs from Gate 22/26, Welfare KRA Office and Kipevu Warehouse2).</p>		
			<p>3. PABX ROOM (Approx. Distance 100m from Enforcement) Fibre cable from Enforcement to PABX ROOM involves: - Deployment of 1x16 core/pair Outdoor Armoured Multicore Single mode Fibre Cable - The Optic fibre cable shall run from Enforcement Office to PABX 15U Cabinet (Approx. Distance 200m). -Termination of Two pairs shall be done on both ends.</p>		
			<p>4. KPA IT SERVER ROOM (Approx. Distance 100m from Enforcement) Fibre cable from enforcement to KPA HQ IT SERVER ROOM involves: - Deployment of a 1x16 core/pair Outdoor Armoured Multicore Single mode Fibre Cable - The Optic fibre cable shall run from Enforcement Office to a 32U Cabinet (Approx. Distance 100m). -Termination of Two pairs shall be done on both ends. -All fibre cables on the server room for kra be relocated to the new 32U cabinet.</p>		

No.	Location	Scope of Works	Description	Bidder's Response	Remark
			<p>5. KAPENGURIA REGIONAL SCANNER OFFICE (KRSO) (Approx. Distance 1.5km from Enforcement)</p> <p>Fibre cable from Enforcement to KRSO involves:</p> <ul style="list-style-type: none"> - Deployment of a 1x16 core/pair Outdoor Armoured Multicore Single mode Fibre Cable. - The Optic fibre cable shall run from enforcement to KRSO new 15U Cabinet. - Fibre cable running from Kapenguria RSO to enforcement shall have splicing to interconnect Kapenguria MSO office. <p>Termination and Splicing:</p> <ul style="list-style-type: none"> - Four pairs (two from enforcement&two from KMSO) of the 16 core cable running to enforcement shall be terminated at the 15U cabinet of KRSO. - Splicing of two pair fibre strands between RSO cable and KMSO_16 core cable to be done on the main distribution manhole located next to KPA POP in kapenguria. <p>KMSO. (Approx. Distance 1km from KRSO) Fibre cable from KMSO to RSO involves:</p> <ul style="list-style-type: none"> - Deployment of an 16 core/pair Outdoor Armoured Multicore Single mode Fibre Cable - The Optic fibre cable shall run from KMSO to main distribution manhole located next to KPA POP in kapenguria. -Splicing of fibre cables between RSO cable and KMSO_16 core cable to be done on the main distribution manhole located next to KPA POP in kapenguria. -Termination of two pairs from the 16core shall be done on KMSO 15UCabinet. 		

No.	Location	Scope of Works	Description	Bidder's Response	Remark
2	GATE 9/10 (POP 2)	LAN INSTALLATION	<p>WORKS: Gate 9/10 It will involve:</p> <ul style="list-style-type: none"> - Additional data points are required. - The required number of Data Points is 16. - Gate 9 to have 4 points and Gate 10 to have 4 points. - Gate 9/10 Offices to have 8 new data points. - Overhead outdoor Ethernet cabling shall be done between the TWO Gate Ramps - Existing Ethernet LAN switch to be replaced with a new LAN PoE switch. <p>Termination -It will involve LAN T568 B termination of Ethernet cable on both RJ45 module and Ethernet patch panel</p>		Fundamental
			<p>LAN Equipment's:</p> <ul style="list-style-type: none"> - 1x24 PoE+ Port Ethernet Network Switch with 4 SFP Gig Ports. - 32U Cabinet (incl. of Vertical AND Horizontal Cable managers) - Replace all current Ethernet switches at gate 9/10 - 1x1500 VA Rack Mountable UPS 		
			<p>Accessories:</p> <ul style="list-style-type: none"> - Ethernet Patch Panel - SFP Transceiver Modules - 3 meter Fibre Patch Cords - 1 meter and 5 meter Ethernet Patch Cords - Metallic Trunking - RJ 45 Data Modules - Data Faceplates - Outdoor Shielded Ethernet Cable - Cat 6a UTP Ethernet Cable 		
FIBRE CONNECTION	<p>WORKS: GATE 9/10 (Approx. Distance 3km from Enforcement).</p> <p>Fibre cable from Enforcement to Gate 9/10 involves:</p> <ul style="list-style-type: none"> - The TWO - 24(2x24) core/pair Outdoor Armoured Multicore 				

No.	Location	Scope of Works	Description	Bidder's Response	Remark
			<p>Single mode Fibre Cables from enforcement shall be spliced in the 42U cabinet of Gate 9/10.</p> <p>-Gate 9/10 will be the main source of backhaul fibre cables to four other sites which are Shed 5 (also serving warehouse one), Gate 12/13 (also serving MCC), G Shade, G Scanner and Marine.</p> <p>Terminations:</p> <p>>Four pairs (two primary pair and two secondary pair) from both 24 pair fibre cables shall be terminated on both ends to serve Gate 9/10 LAN.</p> <p>>All terminations to be done inside Gate 9/10 Cabinet.</p> <p>>Each Site shall be served by two pairs of fibre strands from Enforcement and from the last mile site e.g. G Sections, Shed 5.</p> <p>>Terminations of 16 core fibre cable shall be coming from:</p> <ul style="list-style-type: none"> - Marine - Shed 5: It will include fibre cable pairs from Warehouse 1. - G section. - G Scanner - Gate 12/13: It will include fibre cable pairs serving MCC <p>Fibre Equipment's:</p> <ul style="list-style-type: none"> - Fibre Patch Panel - SFP Transceiver Modules - 3 meter Fibre Patch Cords 		
			<p>WORKS:</p> <p>FIBRE FROM GATE9/10 TO OTHER OFFICES</p> <p>Several armoured outdoor multicore single mode fibre optic cables shall run to Five Locations. The locations include:</p> <p>1. Marine Unit (Approx. Distance 200m from Gate 9/10)</p> <p>Fibre cable from Gate 9/10 to Marine involves:</p> <ul style="list-style-type: none"> - Deployment of an 1x16 core/pair Outdoor Armoured Multicore Single mode Fibre Cable 		

Section VII – Works Requirements 2-177

No.	Location	Scope of Works	Description	Bidder's Response	Remark
			<p>- The Optic fibre cable shall run from Gate 9/10 to Marine 15U Cabinet offices.</p> <p>Civil Works:</p> <ul style="list-style-type: none"> - A man hole near KEBs offices shall be used to connect to the marine office. From the man hole, a distance of 10 meters will involve removal of cabro blocks, dig a trench, lay a conduit for the fibre and return the cabro blocks back to its previous state. - The rest of the distance (80 meters) to the marine office shall involve digging a trench up-to 2 feet, lay a conduit and fill back the trench (1st feet to have the warning strip). <p>Termination:</p> <p>>Two pairs from the 8 core cable will be terminated at the marine 15U cabinet.</p> <p>>At Gate 9/10 42U cabinet: It shall have termination of two pairs from each 16 core cable uplinks from G Section Offices & Scanner, Shed 5, Marine&Gate12/13</p>		

No.	Location	Scope of Works	Description	Bidder's Response	Remark
			<p>2. Gate 12/13 (Approx. Distance 2.5km from Gate 9/10) Fibre cable from gate 9/10 to Gate 12/13 involves: - Deployment of a 1x16 core/pair Outdoor Armoured Multicore Single mode Fibre Cable. - The Optic fibre cable shall run from Gate 9/10 to Gate 12/13 15U Cabinet offices. - Gate 12/13 shall have an uplink to interconnect MCC office.</p> <p>Termination: - Two pairs of the 16 core cable shall be terminated at the 15 U cabinet of Gate12/13. - Two pairs shall be terminated coming from MCC Uplink 16 core cable.</p> <p>MCC Fibre cable from Gate 12/13 to MCC involves: - Deployment of a 16 core/pair Outdoor Armoured Multicore Single mode Fibre Cable - The Optic fibre cable shall run from Gate 12/13 Office to MCC 15U Cabinet. -Termination of two pairs from the 16core shall be done on MCC 15UCabinet.</p>		
			<p>3. SHED 5 (Approx. Distance 1.5km from Gate 9/10) Fibre cable from Gate 9/10 to Shed 5 involves: - Deployment of a 16 core/pair Outdoor Armoured Multicore Single mode Fibre Cable - The Optic fibre cable shall run from gate 9/10 to Shed 5 on a new 32U Cabinet. -Termination of two pairs from the 16 core shall be done on shed 5 to serve Shed 5 LAN. - The Optic fibre cable shall run from Shed 5 to Gate9/10 42U Cabinet. - Shed 5 shall have an uplink to interconnect Warehouse 1 offices.</p> <p>Termination:</p>		

Section VII – Works Requirements 2-179

No.	Location	Scope of Works	Description	Bidder's Response	Remark
			<ul style="list-style-type: none"> - Two pairs of the 16 core cable shall be terminated at the 32 U cabinet of Gate 9/10. - Termination of two pairs of fibre strands from Warehouse1 cable shall be at Shed 5 32 U cabinet. <p>Warehouse 1 (Approx. Distance 250m from Shed 5) Fibre cable from Shed 5 to Warehouse involves: - Deployment of a 16 core/pair indoor Multicore Multi mode Fibre Cable - The Optic fibre cable shall run from Shed 5 Office to Warehouse1 15U Cabinet. -Termination of two pairs from the 16core shall be done on warehouse 15U Cabinet. -Deployment of the fibre shall be on the surface wall of shed 5 to the adjoining building which is warehouse1.It will involve joining of heavy duty conduits from shed five IT Room to the Warehouse Office.</p>		
			<p>4. G Section Shed (Approx. Distance 1.4km from Gate 9/10) Fibre cable from Gate 9/10 to G Shed involves: - Deployment of a 16 core/pair Outdoor Armoured Multicore Single mode Fibre Cable - The Optic fibre cable shall run from gate 9/10 to G Shed to a new 42U free standing Cabinet. -Termination of two pairs from the 16 core shall be done on G shed Cabinet to serve G Shed LAN.</p>		

No.	Location	Scope of Works	Description	Bidder's Response	Remark
			<p>5. G scanner Unit/Office (Approx. Distance 1.2km from Gate 9/10)</p> <p>Fibre cable from Gate 9/10 to G Scanner involves:</p> <ul style="list-style-type: none"> - Deployment of a 16 core/pair Outdoor Armoured Multicore Single mode Fibre Cable - The Optic fibre cable shall run from Gate 9/10 to G Scanner Offices with a new 15U Cabinet. -Termination of two pairs from the 16 core shall be done on G Scanner Cabinet to serve G Scanner LAN. 		

No.	Location	Scope of Works	Description	Bidder's Response	Remark
3	GATE18 COMMUNICATION ROOM (Gate18 CR) (POP 3)	LAN INSTALLATION	WORKS : Gate 18 Communication Room: No LAN will be installed here.It will only be an aggregation point for the fibre cables from satellite offices and backbone cables from KPA Enforcement GATE 18 Main Office It will involve : - Addition of data points. - The required number of Data Points is 12. - Existing Ethernet LAN switch to be replaced with a new LAN PoE switch. Termination -It will involve LAN T568 B termination of Ethernet cable on both RJ45 module and Ethernet patch panel		Fundamental
			LAN Equipment's: - 1x24 PoE+ Port Ethernet Network Switch with 4 SFP Gig Ports. - 42U Free Standing Cabinet (incl. of Vertical AND Horizontal Cable managers) - Replace all existing non-PoE Ethernet switches at Gate 18 Main Office. - 1x1500 VA Rack Mountable UPS		
			Accessories: - Ethernet Patch Panel - SFP Transceiver Modules - 3 meter Fibre Patch Cords - 1 meter and 5 meter Ethernet Patch Cords - Metallic Trunking - RJ 45 Data Modules - Data Faceplates - Outdoor Shielded Ethernet Cable - Cat 6a UTP Ethernet Cable		
FIBER CONNECTION	WORKS: GATE 18 CR (Approx. Distance 1.5km from Enforcement). Fibre cable from Enforcement to Gate 18 CR involves: - The TWO - 24(2x24) core/pair Outdoor Armoured Multicore Single mode Fibre Cables from				

No.	Location	Scope of Works	Description	Bidder's Response	Remark
			<p>enforcement shall be terminated in the 42U cabinet of GATE 18 main communication room.</p> <p>- GATE 18 CR will be the main source of backhaul fibre cables to THREE other sites which are RMG (which shall have uplink to Kipevu CNT2 also serving warehouse two, welfare kra office&Gate 22-26), Gate 20, Fixed Scanner I (also serving Fixed Scanner II)</p> <p>-An interconnecting 16 core outdoor fibre cable shall run between Gate 18 communication room and Gate 18 Main Office</p> <p>Termination:</p> <p>>Four pairs (two primary pair and two secondary pair) from both 24 core fibre cables shall be terminated on both ends to link GATE 18 CR.</p> <p>>All termination to be done inside GATE 18 CR 42UCabinet communication room.</p> <p>>Terminations shall be done for connectivity to last mile sites. i.e. RMG etc.</p> <p>>Each Sites shall be served by two pairs of fibre strands from 16 core cables from the last mile sites e.g. Gate 20, Scanner & RMG etc.</p> <p>>Two pair termination shall be from each corresponding satellite 16 core cables coming from:</p> <ul style="list-style-type: none"> - Gate 20 - RMG: Will uplink Kipevu CNT2. - Fixed Scanner I: Uplink from Fixed Scanner II <p>Fibre Equipment's:</p> <ul style="list-style-type: none"> - Fibre Patch Panel - SFP Transceiver Modules - 3 meter Fibre Patch Cords <p>WORKS:</p> <p>FIBER FROM GATE 18 CR TO OTHER OFFICES</p> <p>Several armoured outdoor multicore single mode fibre optic cable shall run to Three Locations. The locations include:</p>		

No.	Location	Scope of Works	Description	Bidder's Response	Remark
			<p>1. RMG OFFICE:</p> <ul style="list-style-type: none"> - Deployment of an 1x16 core/pair Outdoor Armoured Multicore Single mode Fibre Cable - The Optic fibre cable shall run from Gate18 to a RMG new 32U free standing Cabinet office. -RMG shall serve as uplink to: Kipevu CNT2 (Approx. Distance 2.5Km from GATE 18 CR) <p>Fibre cable from RMG to Kipevu CNT2 involves:</p> <ul style="list-style-type: none"> - Deployment of an 1x16 core/pair Outdoor Armoured Multicore Single mode Fibre Cable - The Optic fibre cable shall run from RMG to Kipevu CNT2 42U free standing Cabinet office. <p>Termination:</p> <ul style="list-style-type: none"> >Two pairs from the 16 core cable will be terminated at the Kipevu CNT2 cabinet to serve the new Kipevu CNT2 LAN. >At the Kipevu CNT2 42U cabinet: <p>Two pair termination shall be done from the 16 core corresponding cables from Warehouse2, Welfare KRA office and Gate22/26 Main Office.</p> <p>Gate 22/26 Main Office (Approx. Distance 900m from Kipevu CNT2)</p> <p>Fibre cable from Kipevu CNT2 to Gate22/26 involves:</p> <ul style="list-style-type: none"> - Deployment of an 16 core/pair Outdoor Armoured Multicore Single mode Fibre Cable - The Optic fibre cable shall run from Kipevu CNT2 Office to Gate22/26 32U Cabinet Main Office. -Termination of two pairs from the 8core shall be done on Gate 22/26 32U Cabinet Main Office. <p>Warehouse2 (Approx. Distance 800m from Kipevu CNT2)</p> <p>Fibre cable from Kipevu CNT2 to Warehouse 2 involves:</p>		

No.	Location	Scope of Works	Description	Bidder's Response	Remark
			<p>- Deployment of an 16 core/pair Outdoor Armoured Multicore Single mode Fibre Cable</p> <p>- The Optic fibre cable shall run from Kipevu CNT2 Office to Warehouse2 15U Cabinet.</p> <p>-Termination of two pairs from the 16core shall be done on warehouse2 15U Cabinet.</p> <p>Welfare KRA Office (Approx. Distance 150m from Kipevu CNT2)</p> <p>Fibre cable from Kipevu CNT2 to Welfare kra office involves:</p> <p>- Deployment of an 16 core/pair Outdoor Armoured Multicore Single mode Fibre Cable</p> <p>- The Optic fibre cable shall run from Kipevu CNT2 Office to Welfare kra office 15U Cabinet.</p> <p>-Termination of two pairs from the 16core shall be done on welfare kra 15U Cabinet.</p>		
			<p>2. Gate 20 (Approx. Distance 400m from GATE 18)</p> <p>Fibre cable from GATE18 to Gate 20 involves:</p> <p>- Deployment of a 1x16 core/pair Outdoor Armoured Multicore Single mode Fibre Cable.</p> <p>- The Optic fibre cable shall run from GATE18 CR to Gate 20 15U Cabinet and two pairs terminated.</p> <p>Termination:</p> <p>-Termination of two pairs from the 16core shall be done on Gate 20 15U cabinet.</p>		
			<p>3. Fixed Scanner I (Approx. Distance 500m from GATE18)</p> <p>Fibre cable from CNT1 to Fixed Scanner I involves:</p> <p>- Deployment of a 1x8 core/pair Outdoor Armoured Multicore Single mode Fibre Cable.</p> <p>- The Optic fibre cable shall run from GATE18 to Fixed Scanner I 32U Cabinet.</p> <p>- An optic fibre cable shall run from Fixed Scanner I cabinet to Fixed Scanner II new 32U cabinet.</p> <p>Termination:</p>		

Section VII – Works Requirements 2-185

No.	Location	Scope of Works	Description	Bidder's Response	Remark
			<p>-Termination of two pairs from the 16core shall be done on Fixed Scanner I 32U cabinet running from Gate 18.</p> <p>- Termination of two pairs from fixed scanner II corresponding 16 core cable as uplink shall be done at Fixed Scanner I 32 U Cabinet.</p> <p>Fixed Scanner II (at Gate 18). (Approx. Distance 20m from Fixed Scanner I)</p> <p>- Deployment of a 1x16core/pair Outdoor Armoured Multicore Single mode Fibre Cable.</p> <p>- Fixed Scanner I shall have two pairs as uplinks to interconnect New Fixed Scanner II office.</p> <p>- Termination of two pairs from the 16core shall be done on Fixed Scanner I 32U cabinet.</p> <p>- Deployment of the fibre shall be on the surface wall of Fixed Scanner I to the adjoining building which is Fixed Scanner II. It will involve joining of heavy duty conduits from Fixed Scanner I to Fixed Scanner II.</p>		

No.	Location	Scope of Works	Description	Bidder's Response	Remark
4	G SECTION /SHED	LAN INSTALLATION	<p>WORKS: G SECTION/SHED OFFICE It will involve:</p> <ul style="list-style-type: none"> - NEW installation of LAN across the G SHED - The required number of Data Points is 60 <p>Termination -It will involve T568B cabling and termination of Ethernet cable on both RJ45 module and Ethernet patch panel.</p> <p>LAN Equipment's:</p> <ul style="list-style-type: none"> - 2x48 PoE+ Port Ethernet Network Switch each with 4 SFP Gig Ports. - 1x42U Free Standing Cabinet (incl. of Vertical AND Horizontal Cable managers) - 1x1500 VA Rack Mountable UPS <p>Accessories:</p> <ul style="list-style-type: none"> - 2X48 Port Ethernet Patch Panel - 4 SFP Transceiver Modules - 3 meter Fibre Patch Cords - 1 meter and 5 meter Ethernet Patch Cords - Metallic Trunking - RJ 45 Data Modules - Data Faceplates - Cat 6a UTP Ethernet Cable 		Fundamental

Section VII – Works Requirements 2-187

No.	Location	Scope of Works	Description	Bidder's Response	Remark
5	MARINE UNIT(MAST)	LAN INSTALLATION	WORKS: MARINE UNIT OFFICE It will involve: <ul style="list-style-type: none"> - NEW installation of LAN across the MARINE UNIT - The required number of Data Points is 16 Termination -It will involve T568B cabling and termination of Ethernet cable on both RJ45 module and Ethernet patch panel.		Fundamental
			LAN Equipment's: <ul style="list-style-type: none"> - 1x24 PoE+ Port Ethernet Network Switch each with 4 SFP Gig Ports. - 1x15U Cabinet (incl. Horizontal Cable managers) - 1x1500 VA Rack Mountable UPS 		
			Accessories: <ul style="list-style-type: none"> - 1x24 Port Ethernet Patch Panel - 2 SFP Transceiver Modules - 3 meter Fibre Patch Cords - 1 meter and 5 meter Ethernet Patch Cords - Metallic Trunking - RJ 45 Data Modules - Data Faceplates - Cat 6a UTP Ethernet Cable 		

No.	Location	Scope of Works	Description	Bidder's Response	Remark
6	G SCANNER CONTROL OFFICE	LAN INSTALLATION	WORKS : G SCANNER OFFICE It will involve : <ul style="list-style-type: none"> - NEW installation of LAN across the G SCANNER CONTROL OFFICE - The required number of Data Points is 12 Termination -It will involve T568B cabling and termination of Ethernet cable on both RJ45 module and Ethernet patch panel.		Fundamental
			LAN Equipment's: <ul style="list-style-type: none"> - 1x24 PoE+ Port Ethernet Network Switch each with 4 SFP Gig Ports. - 1x15U Cabinet (incl. Horizontal Cable managers) - 1x1500 VA Rack Mountable UPS 		

No.	Location	Scope of Works	Description	Bidder's Response	Remark
			Accessories: <ul style="list-style-type: none"> - 1x24 Port Ethernet Patch Panel - 2 SFP Transceiver Modules - 3 meter Fibre Patch Cords - 1 meter and 5 meter Ethernet Patch Cords - Metallic Trunking - RJ 45 Data Modules - Data Faceplates - Cat 6a UTP Ethernet Cable 		

No.	Location	Scope of Works	Description	Bidder's Response	Remark
7	SHED 5	LAN INSTALLATION	WORKS : SHED 5 It will involve : <ul style="list-style-type: none"> - Additional Data points are required - The required number of Data Points is 24 - Replacement of ALL existing switches with new ones. Termination -It will involve T568B cabling and termination of Ethernet cable on both RJ45 module and Ethernet patch panel.		Fundamental
			LAN Equipment's: <ul style="list-style-type: none"> - 1x48 PoE+ Port Ethernet Network Switch each with 4 SFP Gig Ports. - 1x32U Free Standing Cabinet (incl. of Vertical AND Horizontal Cable managers) - 1x1500 VA Rack Mountable UPS - 1x16 Aggregation Switch to be used to connect uplinks from the other several switches in the IT Room in shed 5. 		
			Accessories: <ul style="list-style-type: none"> - 1x24 Port Ethernet Patch Panel - 12 SFP Transceiver Modules - 3 meter Fibre Patch Cords - 1 meter and 5 meter Ethernet Patch Cords - Metallic Trunking - RJ 45 Data Modules - Data Faceplates - Cat 6a UTP Ethernet Cable 		

Section VII – Works Requirements 2-189

No.	Location	Scope of Works	Description	Bidder's Response	Remark
8	WAREHOUSE 1 (Adjoining Shade 5)	LAN INSTALLATION	<p>WORKS : WAREHOUSE1 It will involve :</p> <ul style="list-style-type: none"> - Addition of Data points. - The required number of Data Points is 8 - Replacement of ALL existing switches with new switches. <p>Termination -It will involve T568B cabling and termination of Ethernet cable on both RJ45 module and Ethernet patch panel.</p> <p>LAN Equipment's:</p> <ul style="list-style-type: none"> - 1x24 PoE+ Port Ethernet Network Switch each with 4 SFP Gig Ports. - 1x15U Cabinet (incl. Horizontal Cable managers) - 1x1500 VA Rack Mountable UPS <p>Accessories:</p> <ul style="list-style-type: none"> - 1x24 Port Ethernet Patch Panel - 2 SFP Transceiver Modules - 3 meter Fibre Patch Cords - 1 meter and 5 meter Ethernet Patch Cords - Metallic Trunking - RJ 45 Data Modules - Data Faceplates - Cat 6a UTP Ethernet Cable 		Fundamental

No.	Location	Scope of Works	Description	Bidder's Response	Remark
9	GATE 12/13	LAN INSTALLATION	<p>WORKS: GATE 12/13 It will involve:</p> <ul style="list-style-type: none"> - Addition of Data points. - The required number of Data Points is 8 - Replacement of ALL existing switches with new switches. - Data points to gate ramps shall be done through overhead outdoor shielded UTP cabling. <p>Termination -It will involve T568B cabling and termination of Ethernet cable on both RJ45 module and Ethernet patch panel.</p> <p>LAN Equipment's:</p> <ul style="list-style-type: none"> - 1x24 PoE+ Port Ethernet Network Switch each with 4 SFP Gig Ports. - 1x15U Cabinet (incl. Horizontal Cable managers) - 1x1500 VA Rack Mountable UPS <p>Accessories:</p> <ul style="list-style-type: none"> - 1x24 Port Ethernet Patch Panel - 2 SFP Transceiver Modules - 3 meter Fibre Patch Cords - 1 meter and 5 meter Ethernet Patch Cords - Metallic Trunking - RJ 45 Data Modules - Data Faceplates - Cat 6a UTP Ethernet Cable 		Fundamental

Section VII – Works Requirements 2-191

No.	Location	Scope of Works	Description	Bidder's Response	Remark
10	MCC (Mombasa Convectional Cargo)	LAN INSTALLATION	<p>WORKS: MCC It will involve:</p> <ul style="list-style-type: none"> - NEW installation of LAN across the MCC KRA Offices - The required number of Data Points is 8 <p>Termination -It will involve T568B cabling and termination of Ethernet cable on both RJ45 module and Ethernet patch panel.</p> <p>LAN Equipment's:</p> <ul style="list-style-type: none"> - 1x24 PoE+ Port Ethernet Network Switch each with 4 SFP Gig Ports. - 1x15U Cabinet (incl. Horizontal Cable managers) - 1x1500 VA Rack Mountable UPS <p>Accessories:</p> <ul style="list-style-type: none"> - 1x24 Port Ethernet Patch Panel - 2 SFP Transceiver Modules - 3 meter Fibre Patch Cords - 1 meter and 5 meter Ethernet Patch Cords - Metallic Trunking - RJ 45 Data Modules - Data Faceplates - Cat 6a UTP Ethernet Cable 		Fundamental

No.	Location	Scope of Works	Description	Bidder's Response	Remark
11	KAPENGURIA MOBILE SCANNER OFFICES	LAN INSTALLATION	<p>WORKS : KAPENGURIA MOBILE SCANNER OFFICES It will involve :</p> <ul style="list-style-type: none"> - Addition of data points - The required number of Data Points is 8 - Replacement of ALL existing switches with new switches. - A 15U cabinet already exists <p>Termination -It will involve T568B cabling and termination of Ethernet cable on both RJ45 module and Ethernet patch panel.</p> <p>LAN Equipment's:</p> <ul style="list-style-type: none"> - 1x24 PoE+ Port Ethernet Network Switch each with 4 SFP Gig Ports. - 1x1500 VA Rack Mountable UPS <p>Accessories:</p> <ul style="list-style-type: none"> - 1x24 Port Ethernet Patch Panel - 2 SFP Transceiver Modules - 3 meter Fibre Patch Cords - 1 meter and 5 meter Ethernet Patch Cords - Metallic Trunking - RJ 45 Data Modules - Data Faceplates - Cat 6a UTP Ethernet Cable 		Fundamental

Section VII – Works Requirements 2-193

No.	Location	Scope of Works	Description	Bidder's Response	Remark
12	REGIONAL SCANNER OFFICE (RSO)	LAN INSTALLATION	<p>WORKS : MCC It will involve :</p> <ul style="list-style-type: none"> - NEW installation of LAN across the RSO - The required number of Data Points is 8 <p>Termination -It will involve T568B cabling and termination of Ethernet cable on both RJ45 module and Ethernet patch panel.</p> <p>LAN Equipment's:</p> <ul style="list-style-type: none"> - 1x24 PoE+ Port Ethernet Network Switch each with 4 SFP Gig Ports. - 1x15U Cabinet (incl. Horizontal Cable managers) - 1x1500 VA Rack Mountable UPS <p>Accessories:</p> <ul style="list-style-type: none"> - 1x24 Port Ethernet Patch Panel - 2 SFP Transceiver Modules - 3 meter Fibre Patch Cords - 1 meter and 5 meter Ethernet Patch Cords - Metallic Trunking - RJ 45 Data Modules - Data Faceplates - Cat 6a UTP Ethernet Cable 		Fundamental

No.	Location	Scope of Works	Description	Bidder's Response	Remark
13	GATE 18 MAIN OFFICE	LAN INSTALLATION	<p>WORKS : GATE 18 It will involve :</p> <ul style="list-style-type: none"> - Addition of Data points. - The required number of Data Points is 8 - Replacement of ALL existing switches with new switches. - Data points to gate ramps shall be done through overhead outdoor shielded UTP cabling. <p>Termination -It will involve T568B cabling and termination of Ethernet cable on both RJ45 module and Ethernet patch panel.</p> <p>LAN Equipment's:</p> <ul style="list-style-type: none"> - 1x24 PoE+ Port Ethernet Network Switch each with 4 SFP Gig Ports. - 1x42U Free Standing Cabinet (incl. of Vertical AND Horizontal Cable managers). - 1x1500 VA Rack Mountable UPS <p>Accessories:</p> <ul style="list-style-type: none"> - 1x24 Port Ethernet Patch Panel - 1x24 Aggregation Switch at Gate18 Communication Room - 12 SFP Transceiver Modules - 3 meter Fibre Patch Cords - 1 meter and 5 meter Ethernet Patch Cords - Metallic Trunking - RJ 45 Data Modules - Data Faceplates - Cat 6a UTP Ethernet Cable 		Fundamental

Section VII – Works Requirements 2-195

No.	Location	Scope of Works	Description	Bidder's Response	Remark
14	GATE 20	LAN INSTALLATION	<p>WORKS : GATE 18 It will involve :</p> <ul style="list-style-type: none"> - Addition of Data points. - The required number of Data Points is 8 - Replacement of ALL existing switches with new switches. - Data points to gate ramps shall be done through overhead outdoor shielded UTP cabling. <p>Termination -It will involve T568B cabling and termination of Ethernet cable on both RJ45 module and Ethernet patch panel.</p> <p>LAN Equipment's:</p> <ul style="list-style-type: none"> - 1x24 PoE+ Port Ethernet Network Switch each with 4 SFP Gig Ports. - 1x15U Cabinet (incl. Horizontal Cable managers). - 1x1500 VA Rack Mountable UPS <p>Accessories:</p> <ul style="list-style-type: none"> - 1x24 Port Ethernet Patch Panel - 2 SFP Transceiver Modules - 3 meter Fibre Patch Cords - 1 meter and 5 meter Ethernet Patch Cords - Metallic Trunking - RJ 45 Data Modules - Data Faceplates - Cat 6a UTP Ethernet Cable 		Fundamental

No	Location	Scope of Works	Description	Bidder's Response	Remark
15	FIXED SCANNER I	LAN INSTALLATION	<p>WORKS: FIXED SCANNER I (AT GATE 18) It will involve:</p> <ul style="list-style-type: none"> - Addition of Data points. - The required number of Data Points is 8 - Replacement of ALL existing switches with new switches. - Relocation of existing LAN ethernet patch panels to the new 32U free standing cabinet. <p>Termination -It will involve T568B cabling and termination of Ethernet cable on both RJ45 module and Ethernet patch panel.</p>		Fundamental
			<p>LAN Equipment's:</p> <ul style="list-style-type: none"> - 1x24 PoE+ Port Ethernet Network Switch each with 4 SFP Gig Ports. - 1x32U Free Standing Cabinet (incl. Horizontal Cable managers). - 1x1500 VA Rack Mountable UPS 		
			<p>Accessories:</p> <ul style="list-style-type: none"> - 1x24 Port Ethernet Patch Panel - 4 SFP Transceiver Modules - 3 meter Fibre Patch Cords - 1 meter and 5 meter Ethernet Patch Cords - Metallic Trunking - RJ 45 Data Modules - Data Faceplates - Cat 6a UTP Ethernet Cable 		

Section VII – Works Requirements 2-197

No.	Location	Scope of Works	Description	Bidder's Response	Remark
16	NEW FIXED SCANNER II (at Gate 18)	LAN INSTALLATION	<p>WORKS: NEW FIXED SCANNER II It will involve:</p> <ul style="list-style-type: none"> - NEW installation of LAN across the fixed scanner II control office. - The required number of Data Points is 16 <p>Termination -It will involve T568B cabling and termination of Ethernet cable on both RJ45 module and Ethernet patch panel.</p> <p>LAN Equipment's:</p> <ul style="list-style-type: none"> - 1x24 PoE+ Port Ethernet Network Switch each with 4 SFP Gig Ports. - 1x15U Cabinet (incl. Horizontal Cable managers) - 1x1500 VA Rack Mountable UPS <p>Accessories:</p> <ul style="list-style-type: none"> - 1x24 Port Ethernet Patch Panel - 2 SFP Transceiver Modules - 3 meter Fibre Patch Cords - 1 meter and 5 meter Ethernet Patch Cords - Metallic Trunking - RJ 45 Data Modules - Data Faceplates - Cat 6a UTP Ethernet Cable 		Fundamental

No.	Location	Scope of Works	Description	Bidder's Response	Remark
17	KIPEVU WAREHOUSE 2	LAN INSTALLATION	<p>WORKS: KIPEVU WAREHOUSE 2 It will involve:</p> <ul style="list-style-type: none"> - NEW installation of LAN across the Kipevu warehouse office. - The required number of Data Points is 16 <p>Termination -It will involve T568B cabling and termination of Ethernet cable on both RJ45 module and Ethernet patch panel.</p> <p>LAN Equipment's:</p> <ul style="list-style-type: none"> - 1x24 PoE+ Port Ethernet Network Switch each with 4 SFP Gig Ports. - 1x 32U and 1x 15U Cabinets for ground floor and 1st Floor respectively (incl. Horizontal Cable managers) - 2x1500 VA Rack Mountable UPS <p>Accessories:</p> <ul style="list-style-type: none"> - 1x24 Port Ethernet Patch Panel - 2 SFP Transceiver Modules - 3 meter Fibre Patch Cords - 1 meter and 5 meter Ethernet Patch Cords - Metallic Trunking - RJ 45 Data Modules - Data Faceplates - Cat 6a UTP Ethernet Cable 		Fundamental

Section VII – Works Requirements 2-199

No.	Location	Scope of Works	Description	Bidder Response	Remark
18	GATE 22 - 26	LAN INSTALLATION	<p>WORKS: GATE 22 - 26 It will involve:</p> <ul style="list-style-type: none"> - NEW installation of LAN across the GATES 22 - 26. - The required number of Data Points is 12 - Data points to gate ramps shall be done through overhead outdoor shielded UTP cabling. <p>Termination -It will involve T568B cabling and termination of Ethernet cable on both RJ45 module and Ethernet patch panel.</p> <p>LAN Equipment's:</p> <ul style="list-style-type: none"> - 1x24 PoE+ Port Ethernet Network Switch each with 4 SFP Gig Ports. - 1x32U Cabinet (incl. Horizontal Cable managers) located at the Gates Main Office - 1x1500 VA Rack Mountable UPS <p>Accessories:</p> <ul style="list-style-type: none"> - 1x24 Port Ethernet Patch Panel - 2 SFP Transceiver Modules - 3 meter Fibre Patch Cords - 1 meter and 5 meter Ethernet Patch Cords - Metallic Trunking - RJ 45 Data Modules - Data Faceplates - Cat 6a UTP Ethernet Cable 		Fundamental

No.	Location	Scope of Works	Description	Bidder's Response	Remark
19	KIPEVU CNT 2	LAN INSTALLATION	<p>WORKS: KIPEVU CNT 2 It will involve:</p> <ul style="list-style-type: none"> - NEW installation of LAN across the Joint Task Office (1st floor), Rects Office(1st floor) ,Conference Room(1st floor) and Ground Floor KRA office located inside the Kipevu CNT2 building. - The required number of Data Points is 40 <p>Termination -It will involve T568B cabling and termination of Ethernet cable on both RJ45 module and Ethernet patch panel.</p>		Fundamental
			<p>LAN Equipment's:</p> <ul style="list-style-type: none"> - 1x48 PoE+ Port Ethernet Network Switch each with 4 SFP Gig Ports. - 1x42U free standing Cabinet at ground floor office (incl. of Vertical and Horizontal Cable managers). - A 15 U cabinet shall be fixed at RECTS office to serve all KRA Data points on 1st offices. - 1x1500 VA Rack Mountable UPS 		
			<p>Accessories:</p> <ul style="list-style-type: none"> - 1x48 Port Ethernet Patch Panel - 8 SFP Transceiver Modules - 3 meter Fibre Patch Cords - 1 meter and 5 meter Ethernet Patch Cords - Metallic Trunking - RJ 45 Data Modules - Data Faceplates - Cat 6a UTP Ethernet Cable 		

LOT 2: TECHNICAL SPECIFICATIONS FOR DESIGN, SUPPLY, INSTALLATION, CONFIGURATION AND COMMISSIONING OF AN ENTERPRISE NETWORK MANAGEMENT AND WAN OPTIMISATION SOLUTION.

INSTRUCTIONS TO BIDDERS:

- Bidders **SHALL** provide a detailed and substantive response/ proposal to the stated requirement, regardless of any technical data sheets/brochures/documentation attached.
- Use of **YES, NO, TICKS, COMPLIANT** etc. without providing a detailed and substantive response will be considered **NON-RESPONSIVE** and may lead to disqualification.
- Failure to meet the minimum technical requirements/specifications in **FUNDAMENTAL** clauses will automatically render the item/bid **NON-RESPONSIVE**
- Bidders **SHALL** stamp and sign any attached Technical data sheets.

Scope of Coverage

The following KRA Operational areas are covered under the scope of this (LOT 2) project:

1. Two (2) Data Centers (Primary and Secondary), both located in Nairobi.
2. Kisumu SWAN Centre
3. ICD Embakassi Station
4. Sameer Park Station
5. Customs House Mombasa Station
6. Kilindini
7. Nyeri
8. Embu
9. Eldoret
10. Nakuru
11. JKIA

Functional and Technical Requirements:

Design, Supply, Installation, Configuration and Commissioning of an Enterprise Network Management WAN Optimization Solution

	Requirement	Minimum specifications	Bidder's Response	Remark
1	Background information and General Descriptive Requirement	<p>Kenya Revenue Authority runs an enterprise Hardware, Network and Applications Infrastructure comprising of (but not limited to) the following:</p> <ol style="list-style-type: none"> 1) An enterprise server and hardware infrastructure comprising of Several Standalone and virtualized Servers. 2) An enterprise software, applications and storage infrastructure comprising of over 50 different systems/applications. 3) An enterprise LAN and WAN infrastructure (Logical Star), comprising of Six (6) different Service Providers, over 80 physical locations(WAN nodes), over 4000 LAN nodes and over 5000 users distributed non-uniformly across the physical locations. (Note that current project scope covers two(2) Data Centers and selected ten(10) Branch Stations) 4) Two Data Centers (Primary and Secondary), in active-active configuration, both located in Nairobi. All enterprise services, servers, infrastructure components, applications and systems are hosted in the Data Centers. 5) Internet connection for staff internet access 6) Upstream internet connection for uploading online services to clients and partners. <p>To achieve optimal value from the infrastructure, KRA proposes to acquire an enterprise Network Management and WAN optimization solution to manage how users, traffic, devices and applications behave on the network. This includes the following capabilities:</p> <ol style="list-style-type: none"> 1. Traffic Monitoring on all the various types of MAN, WAN and LAN links. 2. WAN optimization the areas covered under the current scope 3. Delivering complete visibility of enterprise traffic, performance metrics and bandwidth management 4. Enterprise Traffic Management Techniques including Traffic Classification, QoS and Traffic Enforcement 5. Application acceleration and web caching over WAN (or private MPLS, IPVPN, among others) and Internet. 		Fundamental

Section VII – Works Requirements 2-203

	Requirement	Minimum specifications	Bidder's Response	Remark
		<p>Proposed Solution must be an internationally recognized brand, consistently placed in the Gartner Magic Leadership Quadrant report for the last three (3) years in its category.</p> <p>Bidder must specify Type, Brand, series etc. , up to the specific device/solution details</p> <p>(Indicate your proposed solution and describe how it meets all the above requirements.)</p>		
2	Visibility	<p>Proposed Solution must carry out correct identification of the traffic that goes through the data links as required for subsequent analysis, bandwidth control and optimization.</p> <p>This includes (but not limited to):</p> <ol style="list-style-type: none"> 1.Layer 7 Classification, 2.Deep Packed Inspection Techniques, 3.Instant application detection once the equipment is connected to the network, 4.Automatic application classification, <p>(Describe how your proposed solution meets all the above requirements)</p>		Fundamental
3	Interactive Diagnosis	<p>Proposed solution must be able to understand all traffic, users, activities, applications and locations to gain valuable insight into how their critical network resources are being used and monitor critical application performance.</p> <p>(Describe how your proposed solution meets the above requirements)</p>		Fundamental
4	Traffic Control and QoS	<p>Solution must dynamically select the best application path based on application-aware, business intent-based policies, and network availability</p> <p>Utilizes streamlined QoS configuration with per-site exceptions as needed, using centralized, business intent-based policies, and application grouping</p> <p>(Describe how your proposed solution meets all the above requirements)</p>		Fundamental
5	WAN optimization	<p>WAN optimization of business critical / real-time applications e.g. VoIP and VC, ERP, HTTPS among others. The optimization capabilities should include-:</p> <ol style="list-style-type: none"> 1. Leverages multiple optimization techniques, including data, application, and transport streamlining. 2. Improves end-user experience and reduces traffic over direct Internet connections with a fully embedded, transparent HTTP(S) proxy for local connection termination and Web object caching 		Fundamental

	Requirement	Minimum specifications	Bidder's Response	Remark
		3.Bandwidth control with the traffic application optimization in WAN should be able to detect the following components: HTTP, SSL, CIFS, Lotus Notes among others		
7	Centralized Management of the solution	Proposed solution must provide for an easy to use graphical interface for central management, diagnostics, problem resolution and alerting for the network infrastructure using from one console. Solution must provide visibility into how applications are performing and provide Reporting metrics such as traffic levels, application throughput performance, and TCP session flow characteristics Must provide reports on bandwidth usage in a user friendly dashboards that provide at-a-glance views globally, by sites and by application (Describe how your proposed solution meets all the above requirements)		Fundamental
8	Design and Architectural map	Bidders must submit a comprehensive design, schematic and architectural map for their proposal		
9	Licensing	Proposed solution must be inclusive of Perpetual (one time) License(s)		Fundamental

Design, Supply, Installation, Configuration and Commissioning of an Enterprise Network Management and WAN Optimization Solution

1.1 Hardware Technical and Software Specifications:

(1) Data Centre WAN Optimization

	Requirement	Minimum Specifications	Bidder's Response	Remark
1	General Descriptive Requirement	Solution must enforce optimization of all applications, across hybrid networks to users throughout the enterprise. Hardware appliance with must have a enforcement throughput of up to 2 Gbps (Describe how your proposed solution meets all the above requirements)		Fundamental
2	Web Cache Capacity	Proposed Hardware platform must provide a web cache capacity of at least 400Gb		Fundamental
3	Network Interfaces	Proposed Hardware platform must have the following interfaces installed at a minimum: 1.Copper: 4 x 1G bypass bridge pair, 2.Fiber: 2x 1G bypass bridge pair, 4.Upto 20 Bypass ports Describe how your proposed solution meets all the above requirements		Fundamental
4	Data Storage and memory capacity	At least 2.5 TB Storage and 64 GB RAM or equivalent		Fundamental
5	Hardware Requirements	Redundant power supplies Storage fault tolerance using RAID Rack mountable		Fundamental

(2) Branch Stations WAN optimization

	Requirement	Minimum Specifications	Bidder's Response	Remark
1	General Descriptive Requirement	<p>Solution must provide WAN optimization functionality at the Brach office.</p> <p>Solution must have an enforcement throughput of up to 100 Mbps and a WAN capacity up to 500 Mbps</p> <p>must have a enforcement throughput of up to 100 Mbps (Describe how your proposed solution meets all the above requirements)</p>		Fundamental
2	Web Cache Capacity	Proposed Hardware platform must provide a web cache capacity of at least 200Gb		Fundamental
3	Network Interfaces	<p>Proposed Hardware platform must have the following interfaces pre- installed at a minimum:</p> <p>Copper: 4 x 10/100 bypass ports included</p> <p>Must support expansion of ports to at least 10 bypass ports</p> <p>Describe how your proposed solution meets all the above requirements</p>		Fundamental
4	Data Storage and memory capacity	At least 300 GB Storage and 8 GB RAM or equivalent		Fundamental

(3) Centralized Management Solution

	Requirement	Minimum Specifications	Bidder's Response	Remark
1	General Descriptive Requirement	<p>Solution must provide a user friendly web-based dashboard for control and management of users, applications and networks.</p> <p>Must be able to implement an application based approach based on business needs and real-time network performance.</p>		Fundamental

Section VII – Works Requirements 2-207

	Requirement	Minimum Specifications	Bidder's Response	Remark
2	Performance Monitoring and Reporting	Must performance monitoring with reporting metrics such as traffic levels, application throughput performance and TCP session flow characteristics – to help diagnose and fix problems		Fundamental
3	Licensed Devices	Proposed platform must be able to manage at least 2000 devices.		
4	Hardware Platform	Form Factor must be rackable, with a 100-240V 50/60Hz AC Power Supply		Fundamental

1.2 Implementation, Operations, maintenance and Support (Covering entire scope of LOT 2 project)

	Requirement	Requirements Criteria	Bidders Response	Remark
1	Architectural Map	Bidders must submit a comprehensive design, schematic and architectural diagram for their proposed solution		Fundamental
2	Post implementation Support and maintenance	Bidder must provide a comprehensive post implementation support and maintenance plan, including software updates proposal for two (2) years.		Fundamental
3	Manufacturer Support and Warranty	Minimum 2 years on Parts, Labour and software. Equipment must include the manufacturer's premier technical support services. Bidder must provide a letter from the manufacturer committing him to support equipment and services supplied under this tender.		Fundamental
4	Training	Bidder must provide for Comprehensive Manufactures' Hands-on training for at least five (5) KRA staff.		Fundamental

1.3 Commercial terms

	Requirement	Requirements Criteria	Bidders Response	Remark
1	Total Cost of ownership(TCO for 3 Years)	Bidder must provide a comprehensive itemized TCO schedule, including (but not limited to) CAPEX, licensing model and costs etc. 1. One time(CAPEX) cost 2. Perpetual Licence costs. 3. Software updates 4. Support, maintenance, warranty etc		Fundamental

C. IMPLEMENTATION SCHEDULE

Implementation Schedule Table

Bidder to provide for both lots.

D. Attachments

Attachment 1: Site Drawings and Site Survey Information (Lot 1 only)

NETWORK SCHEMATIC DIAGRAMS

A. Proposed Kilindini Local Area Network Schematic Diagrams

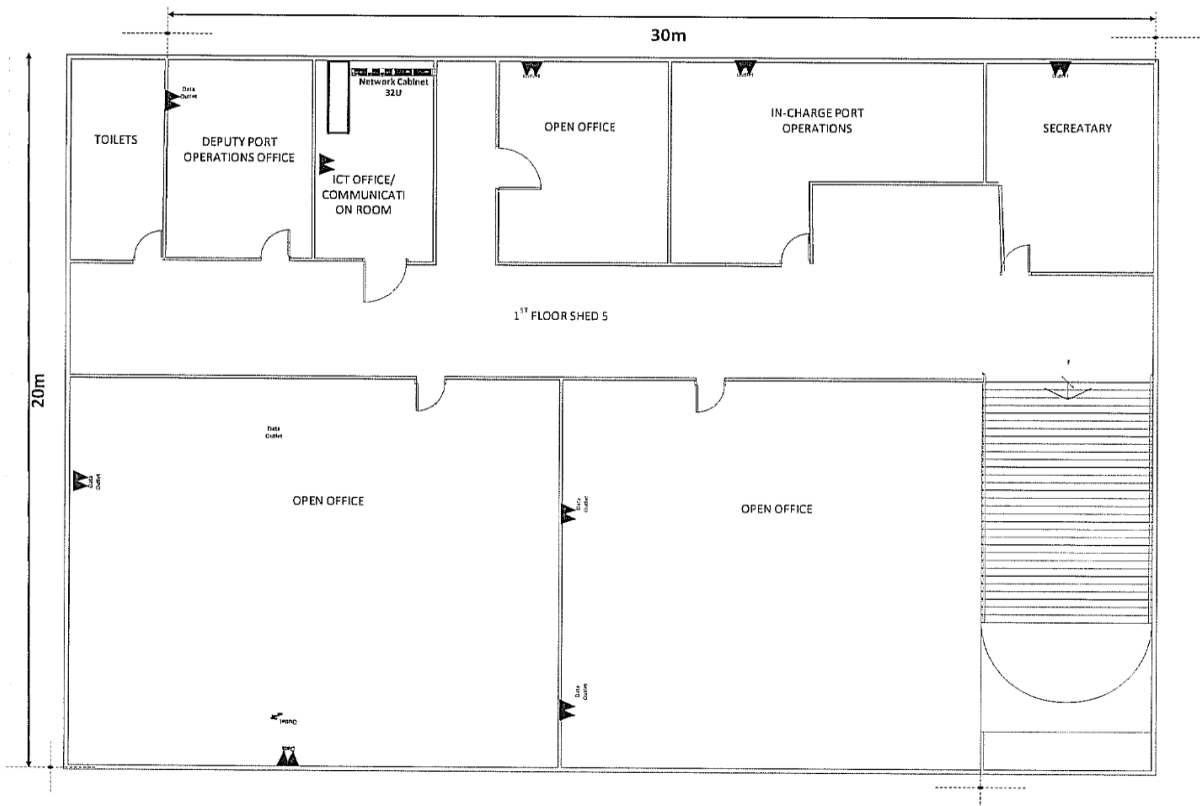

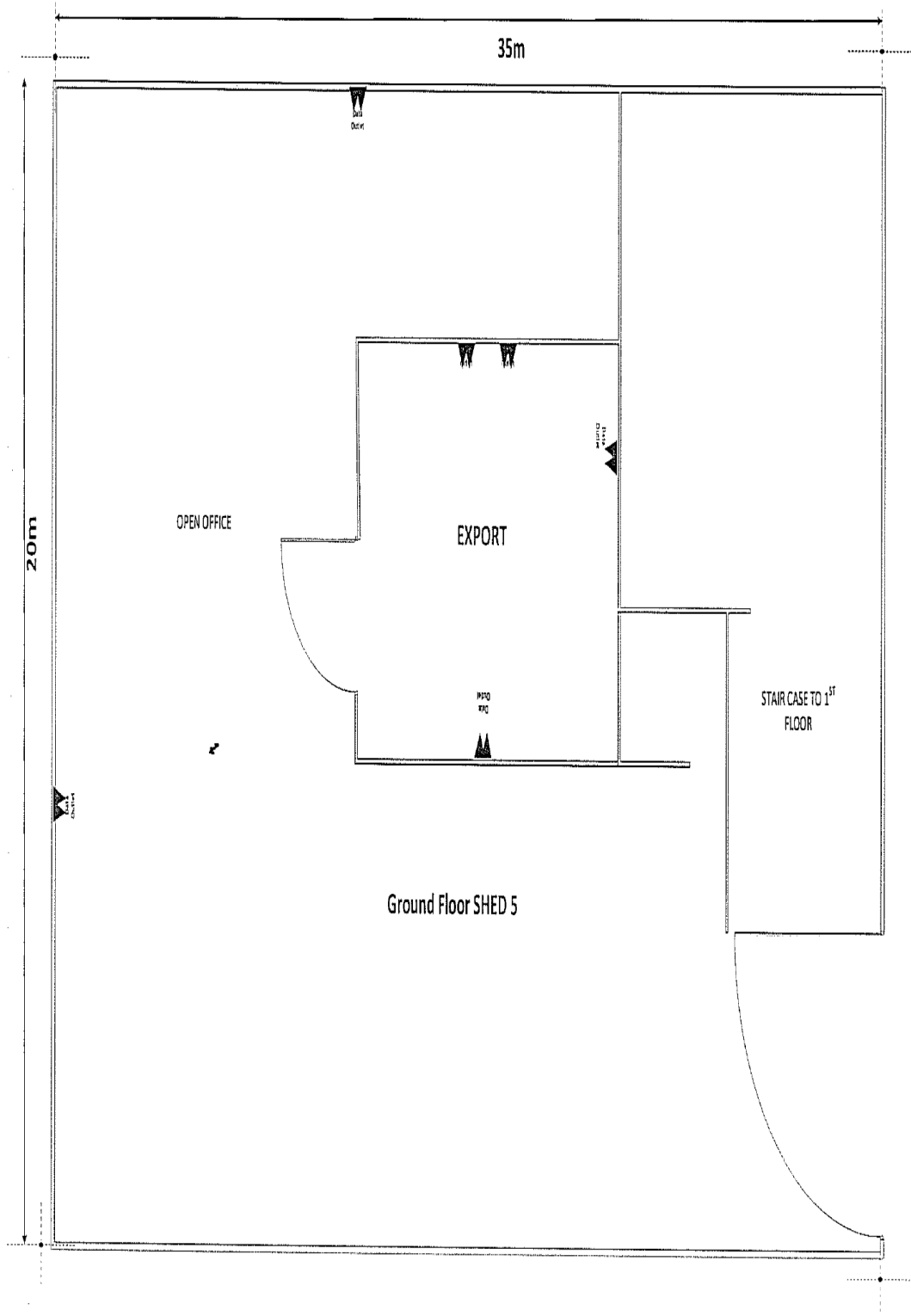

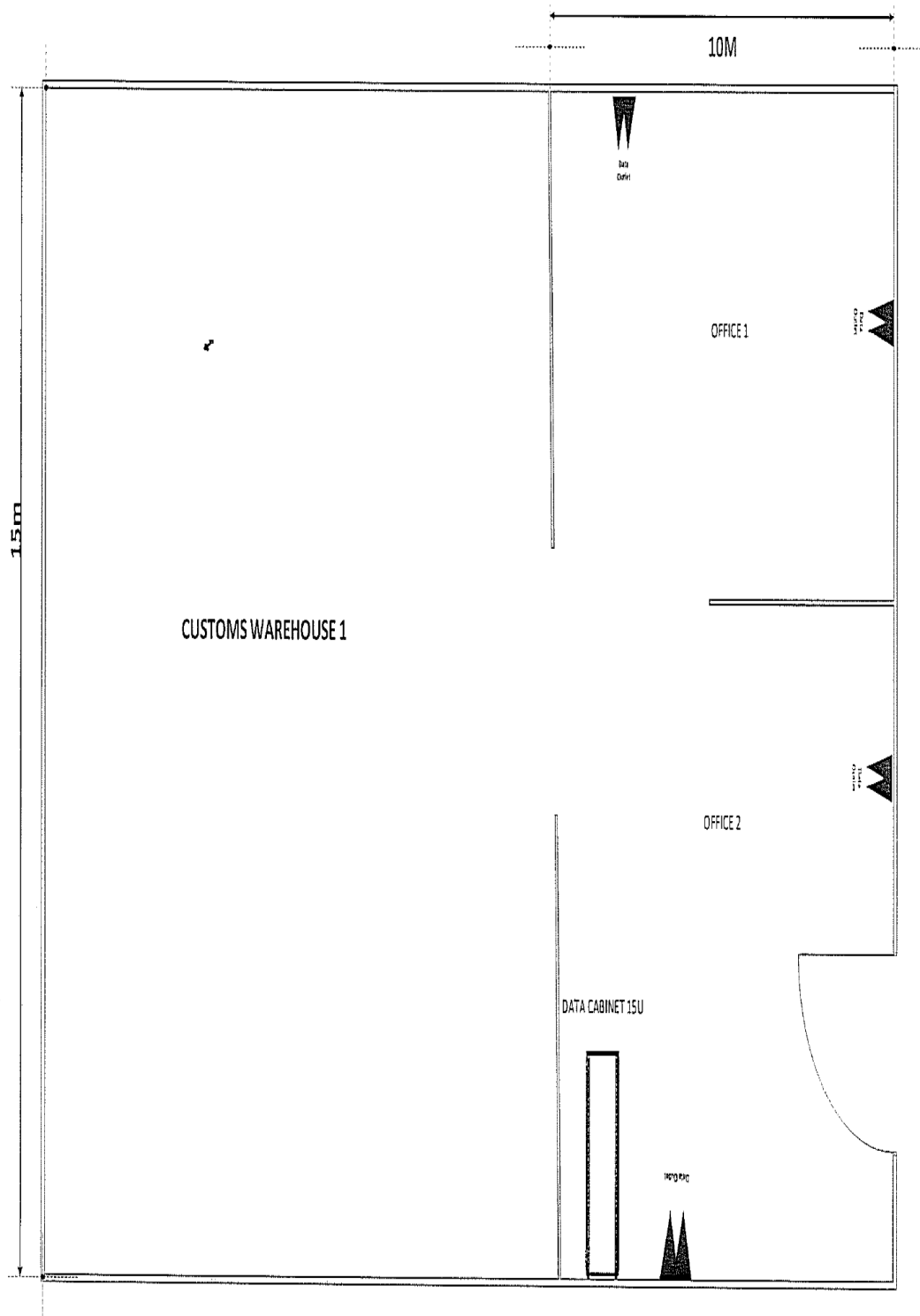

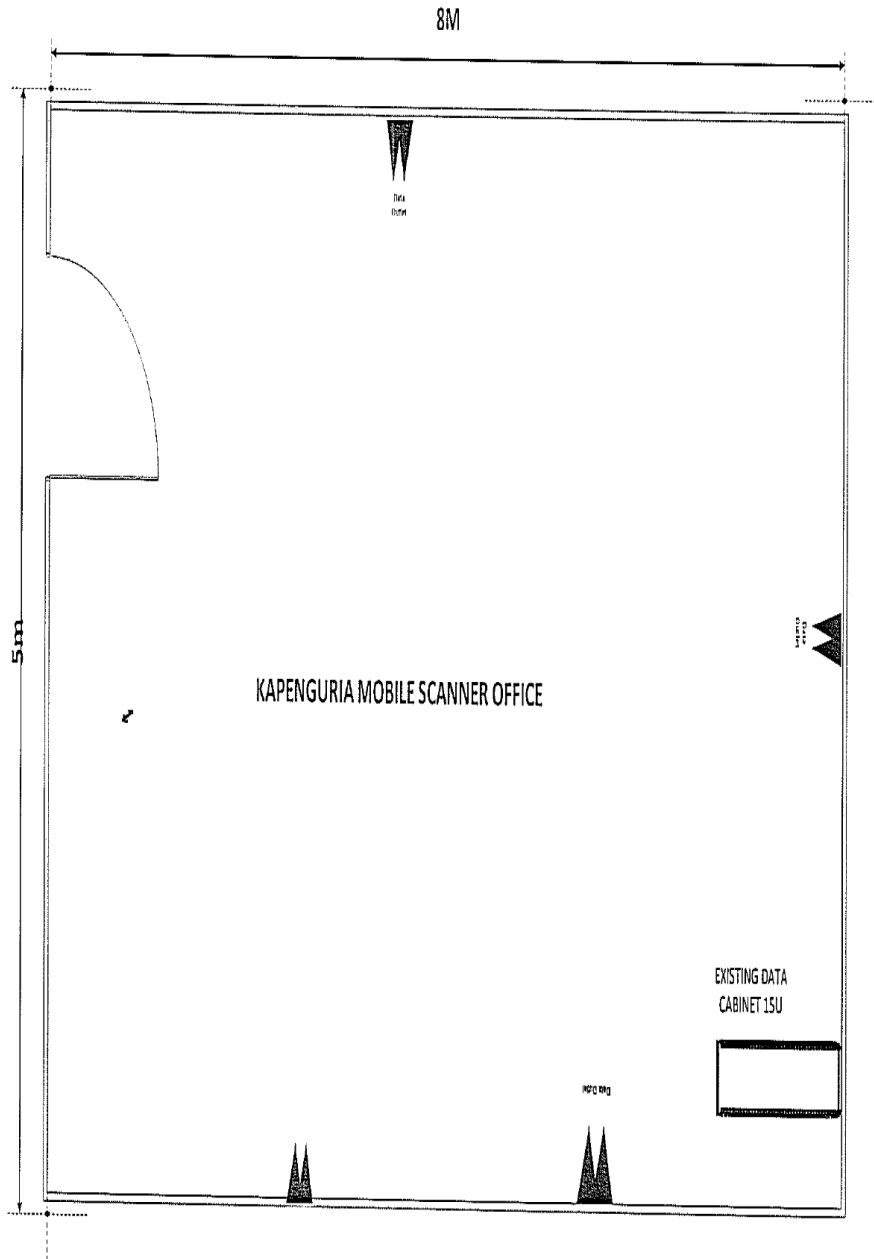

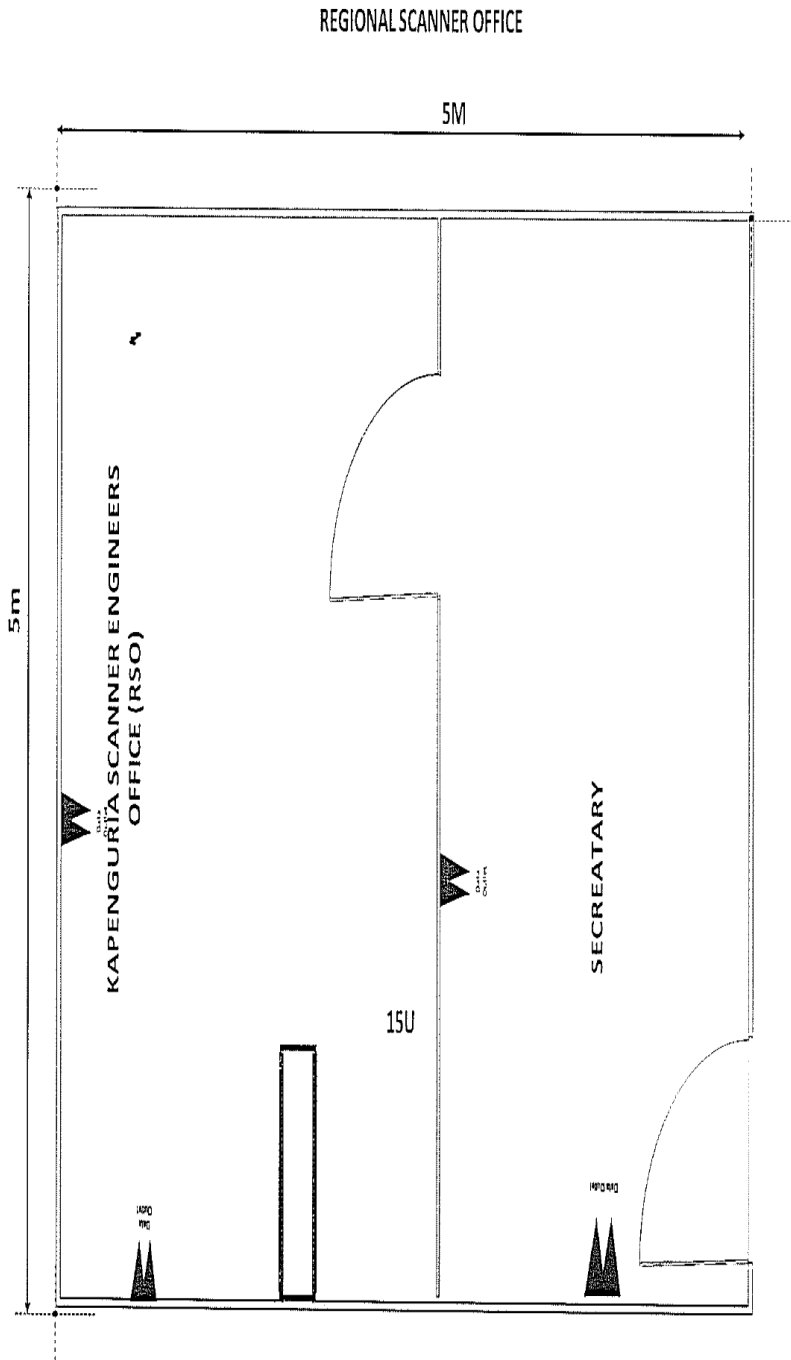

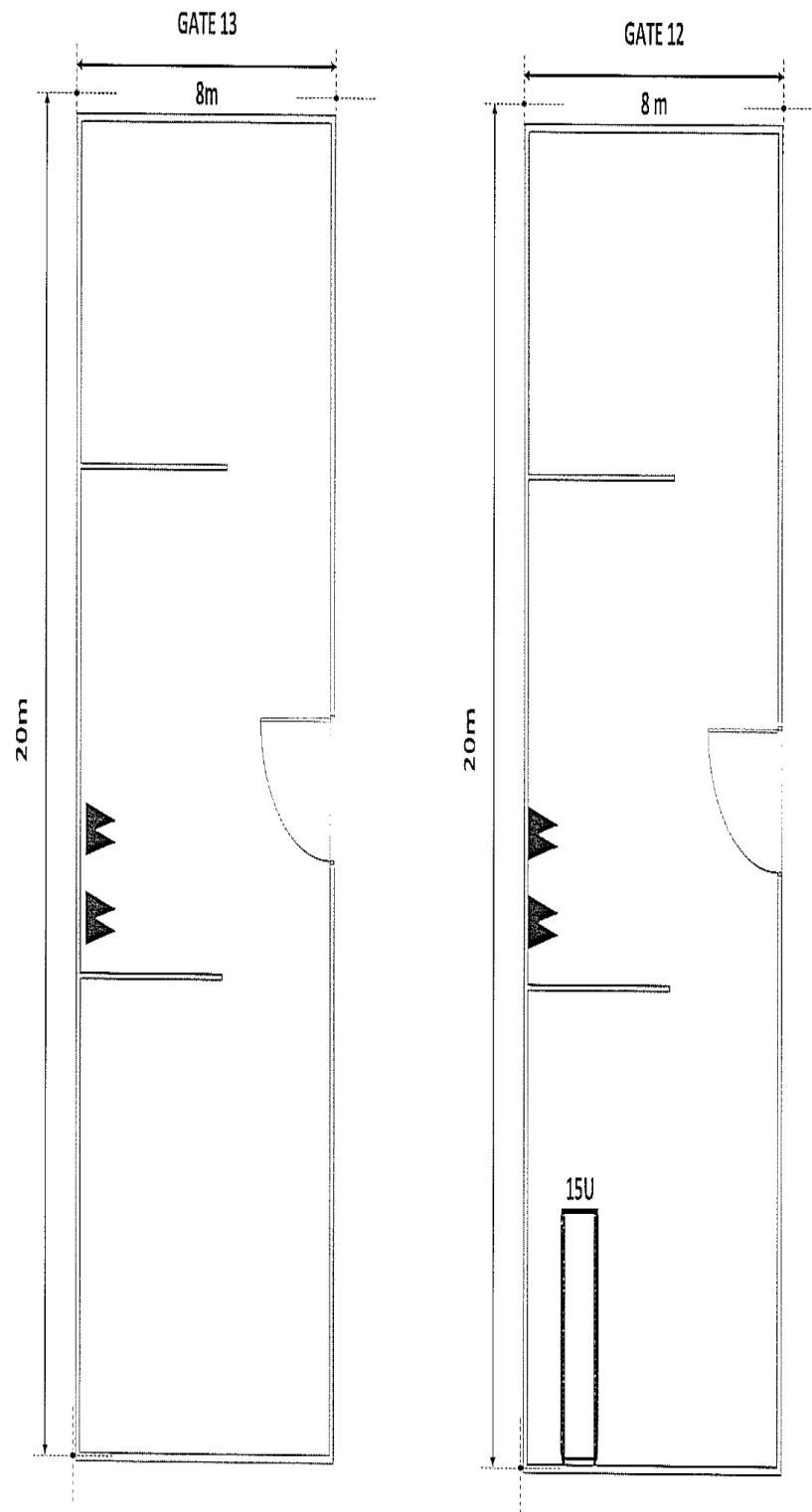

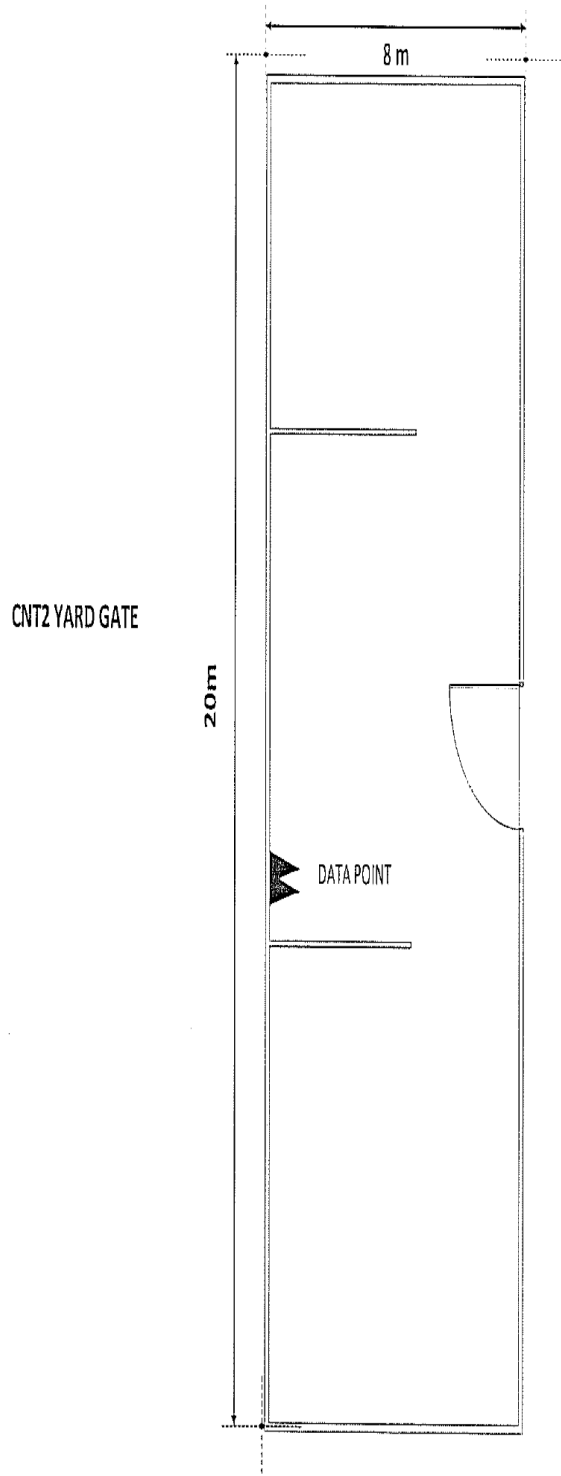

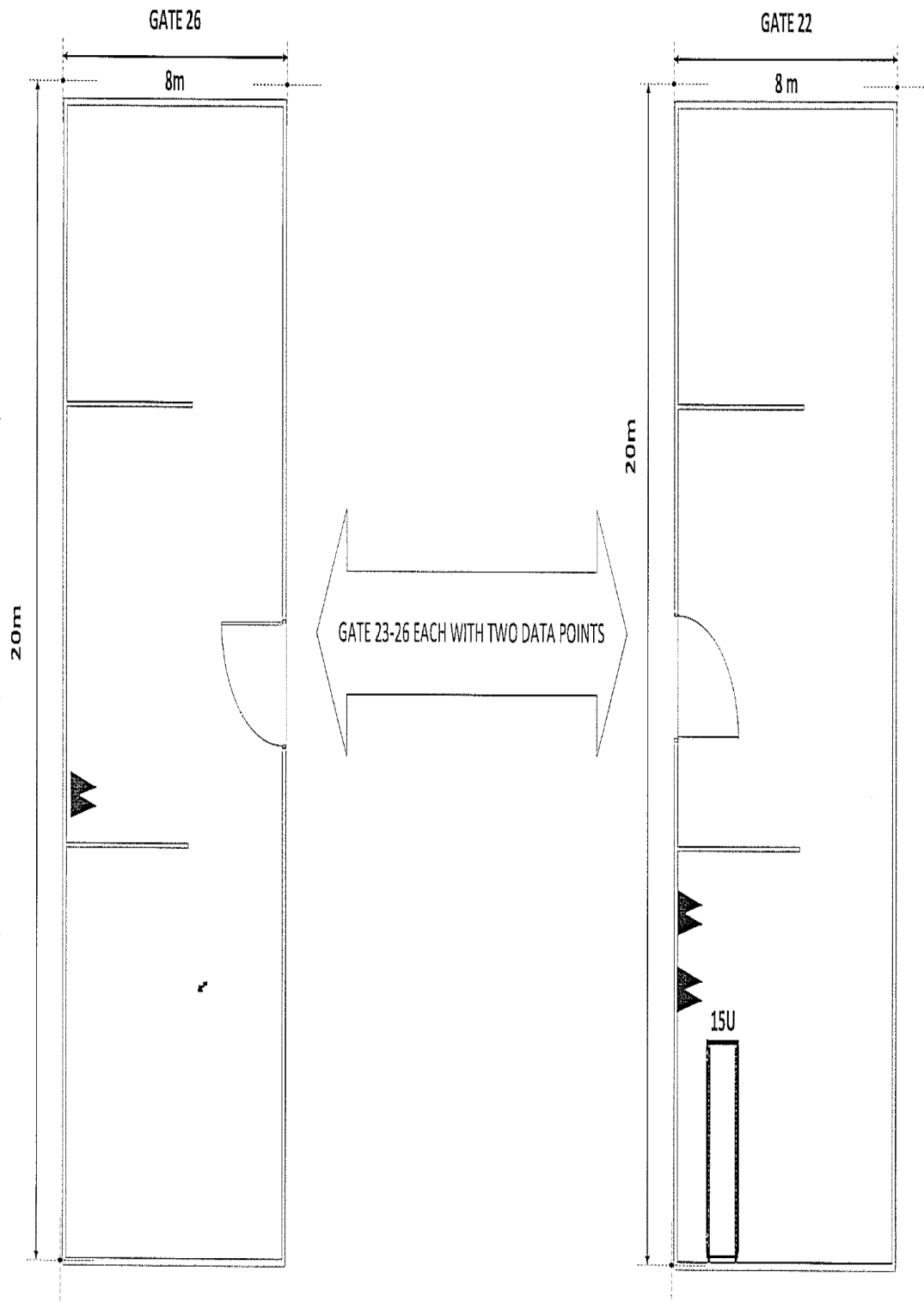



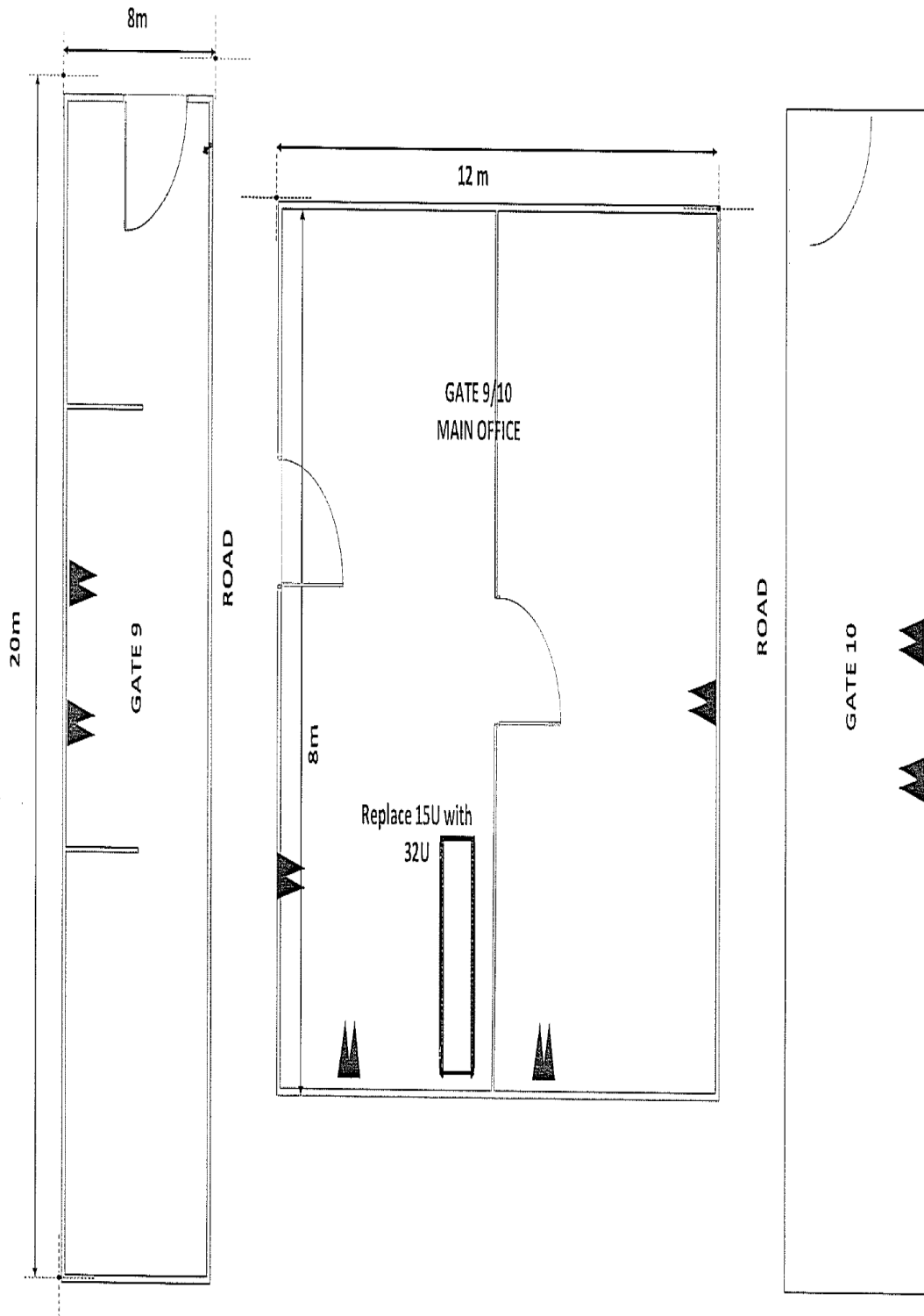

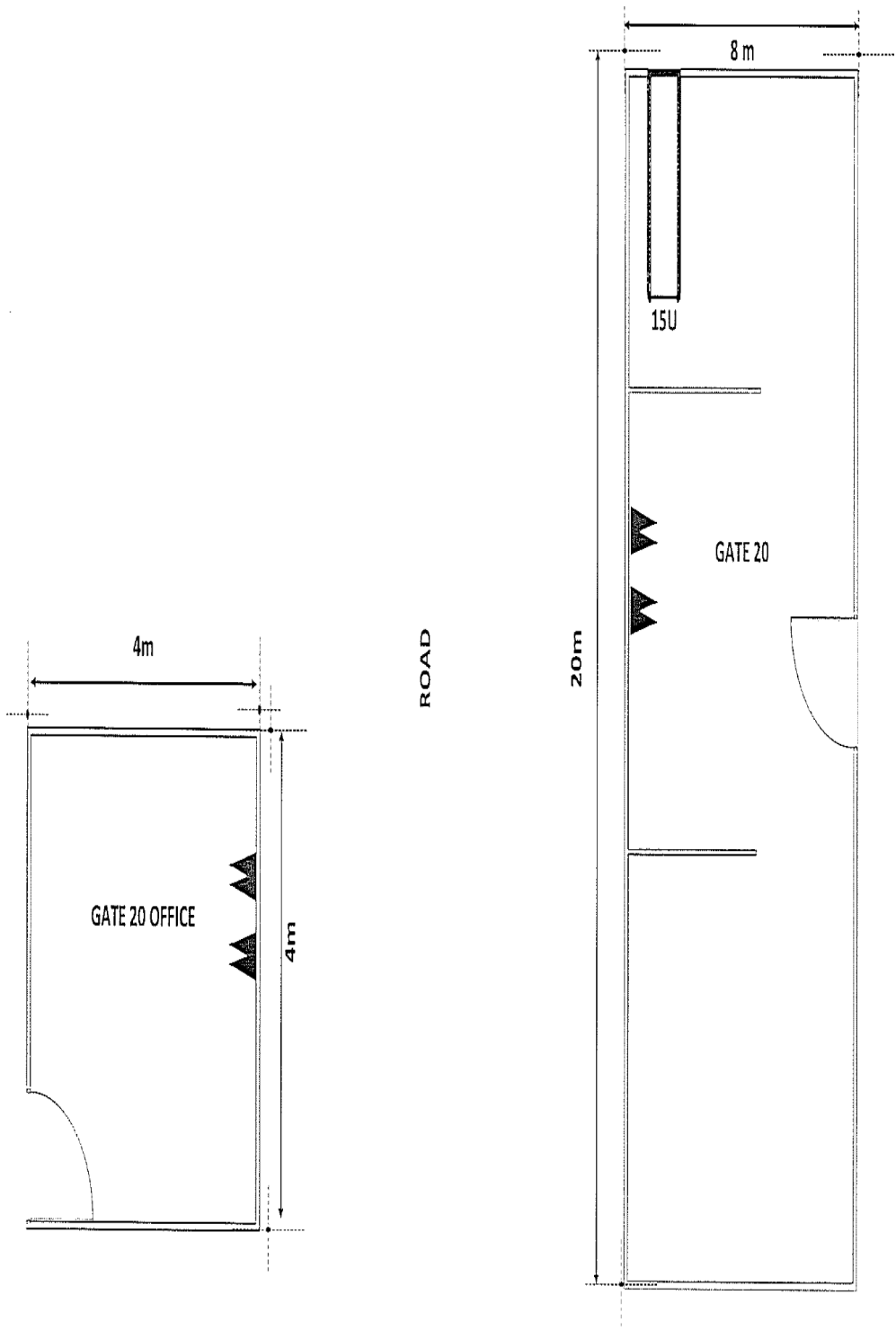

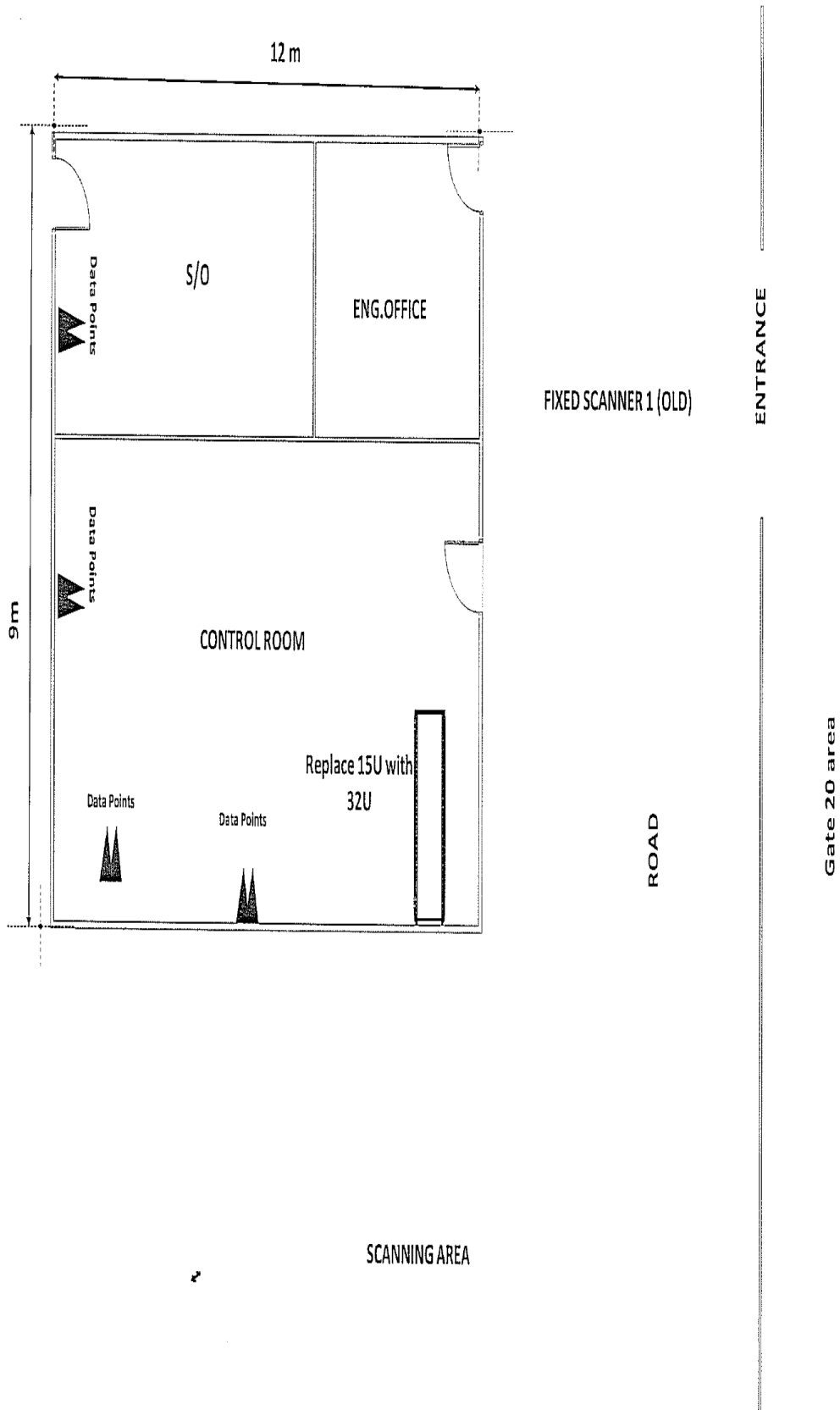

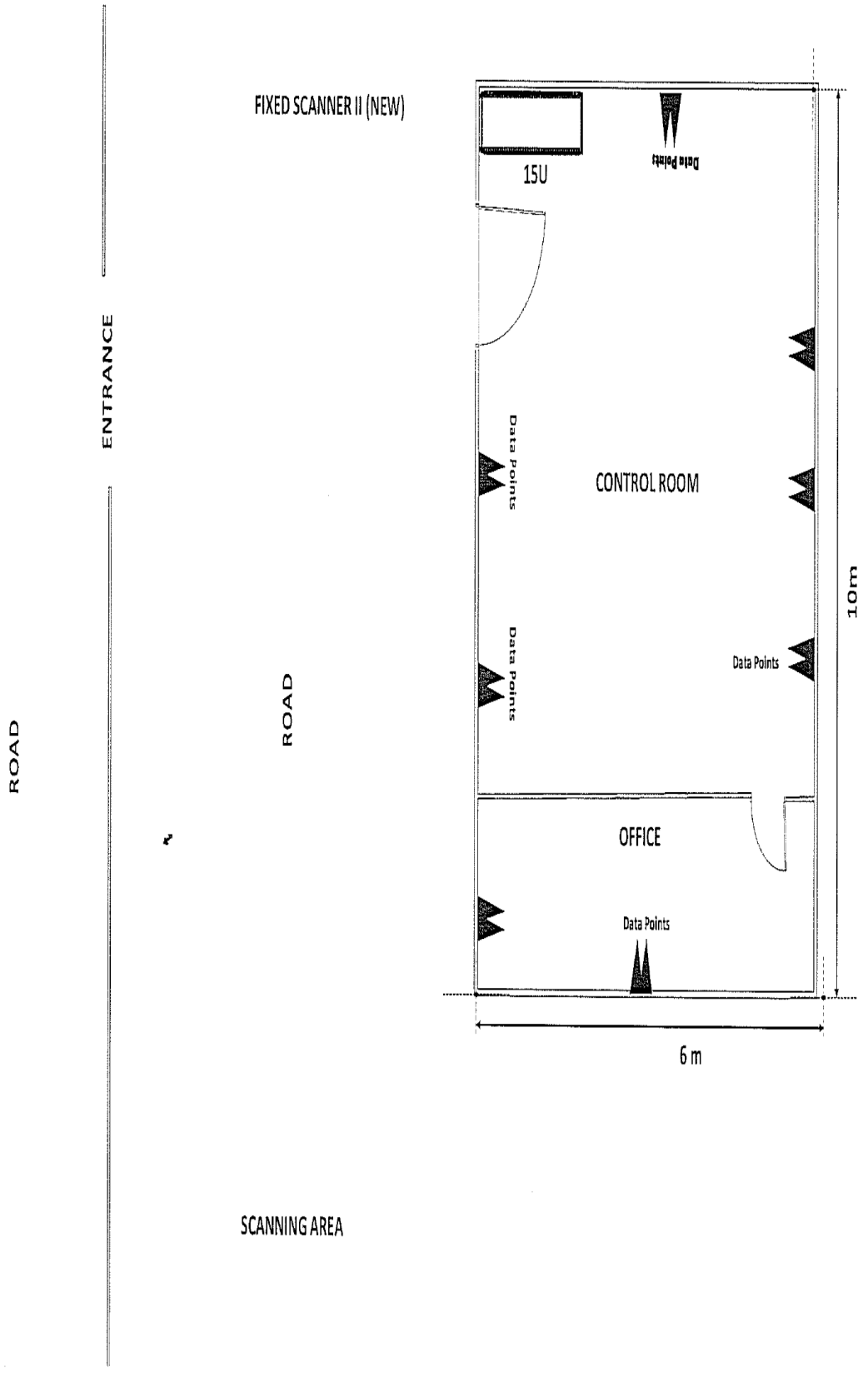

G SECTION SCANNER
CONTROL



GSECTION OFFICES

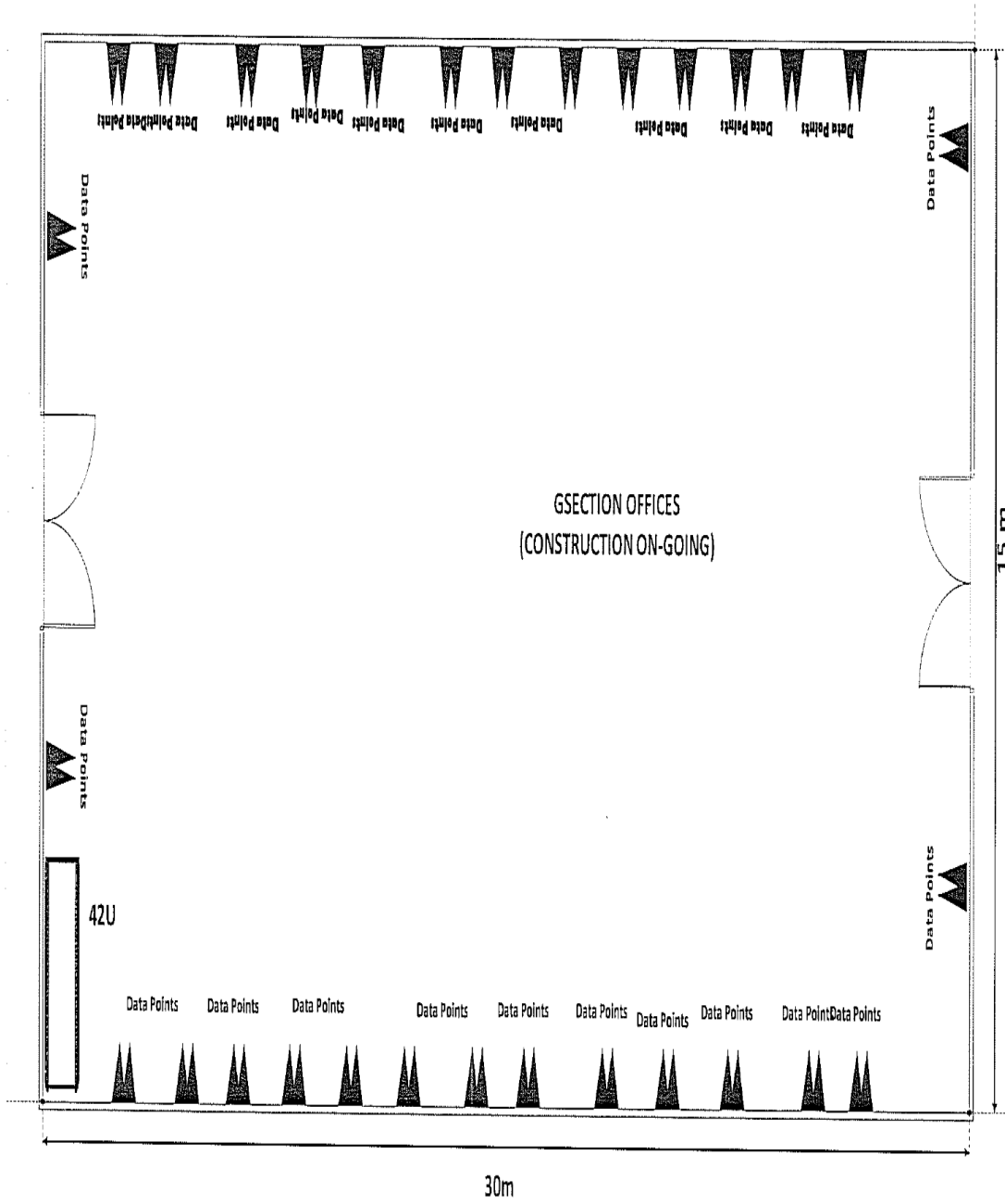

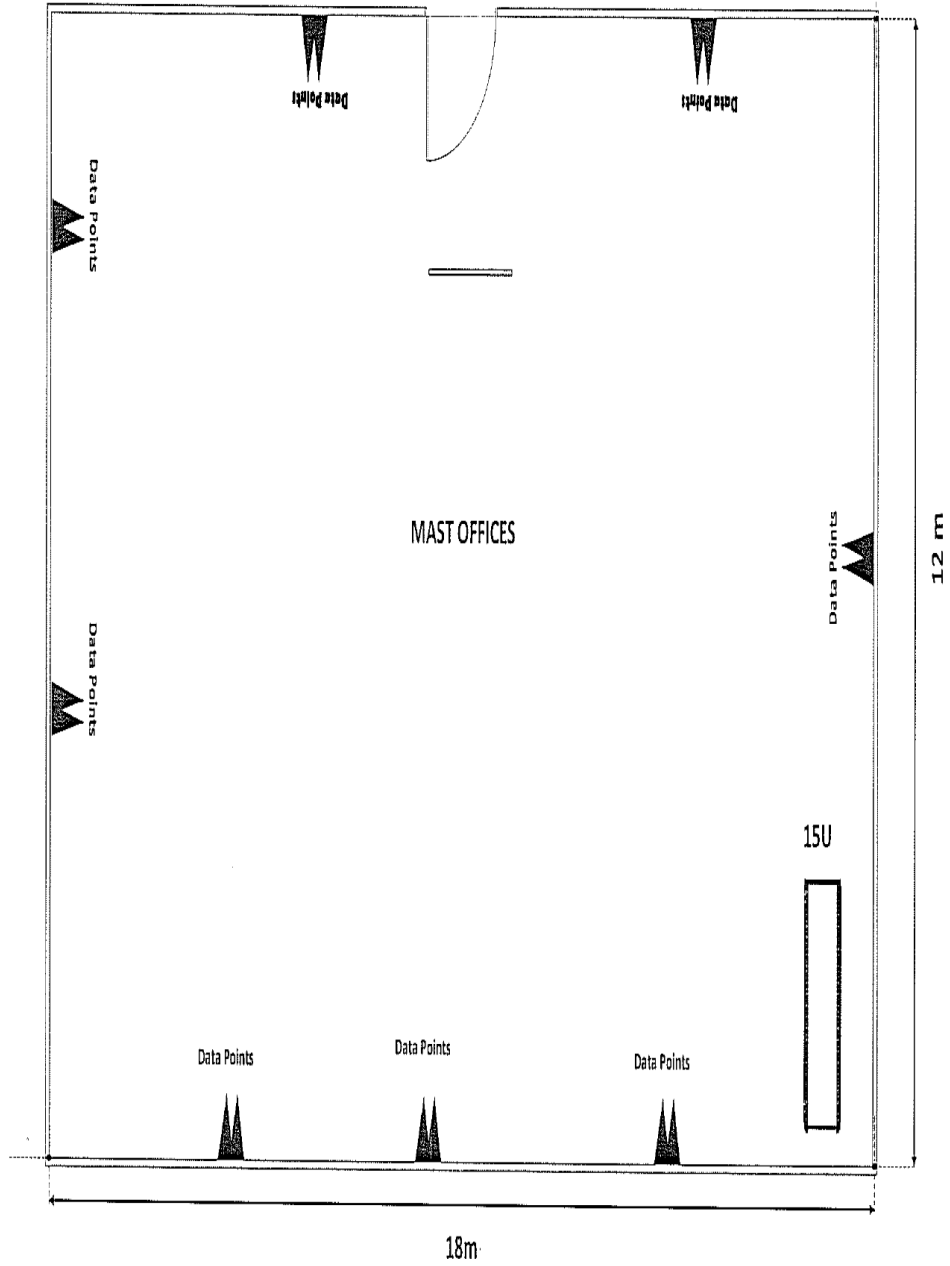

KPA ENFORCEMENT

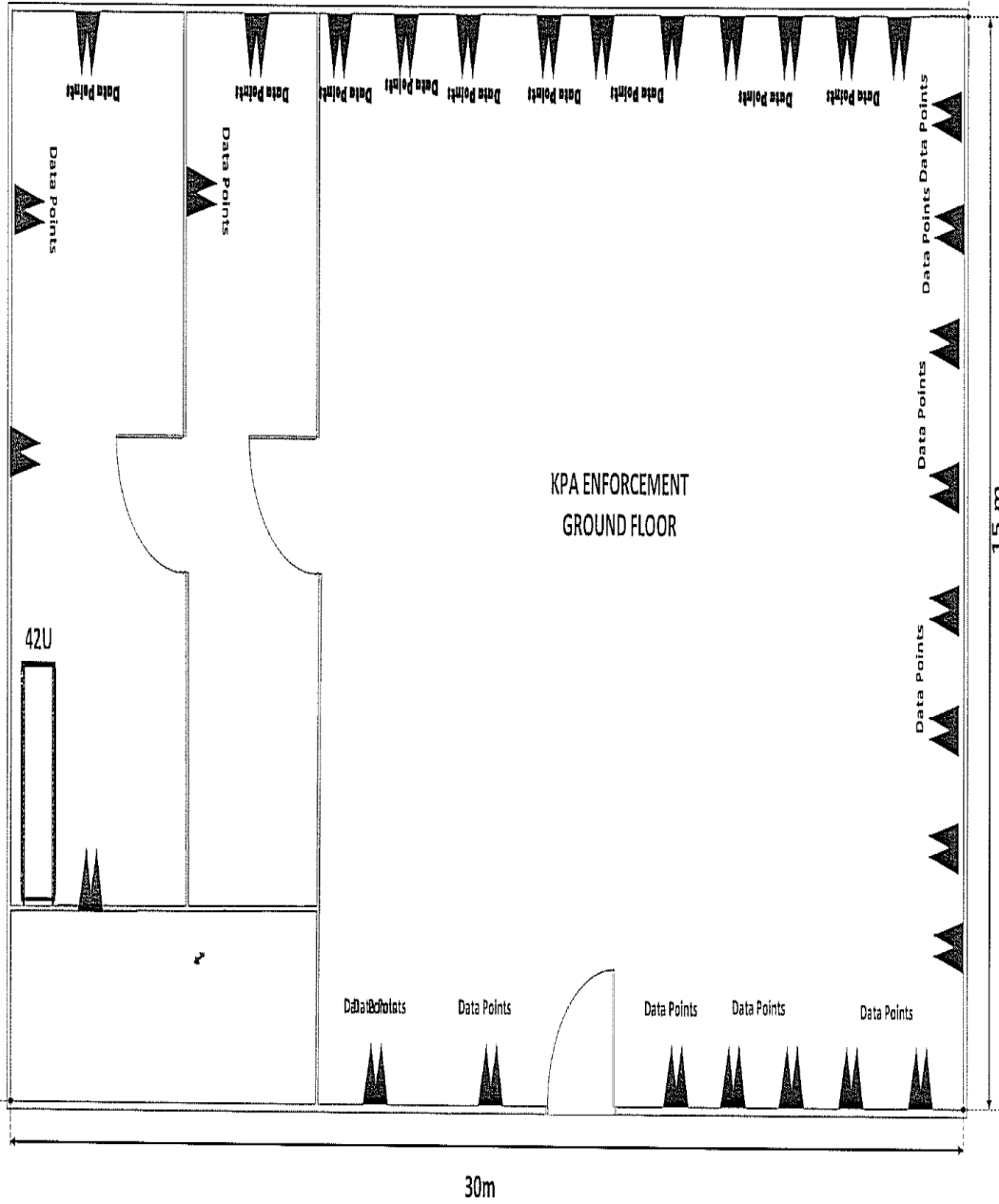

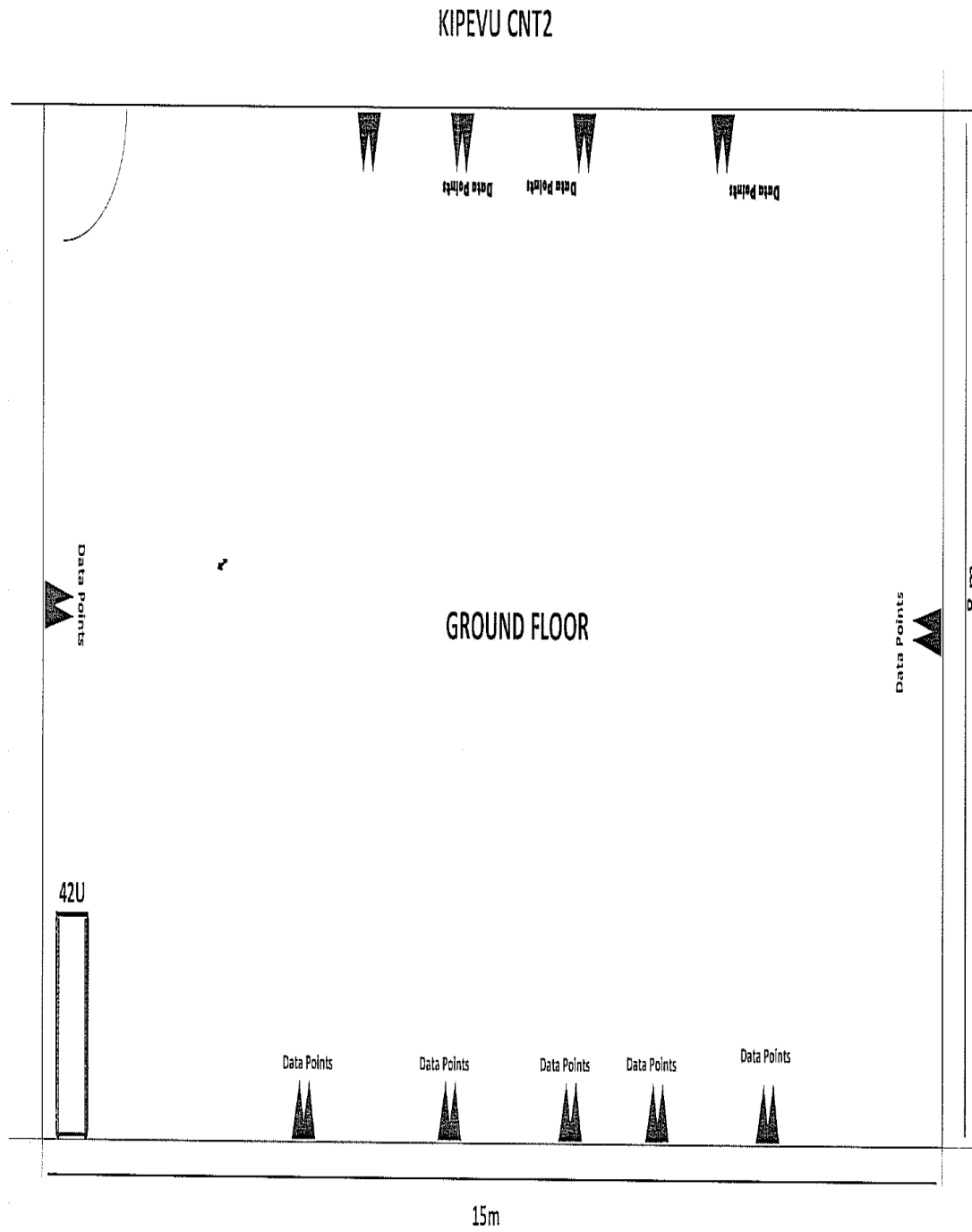

CNT 2 WAREHOUSE

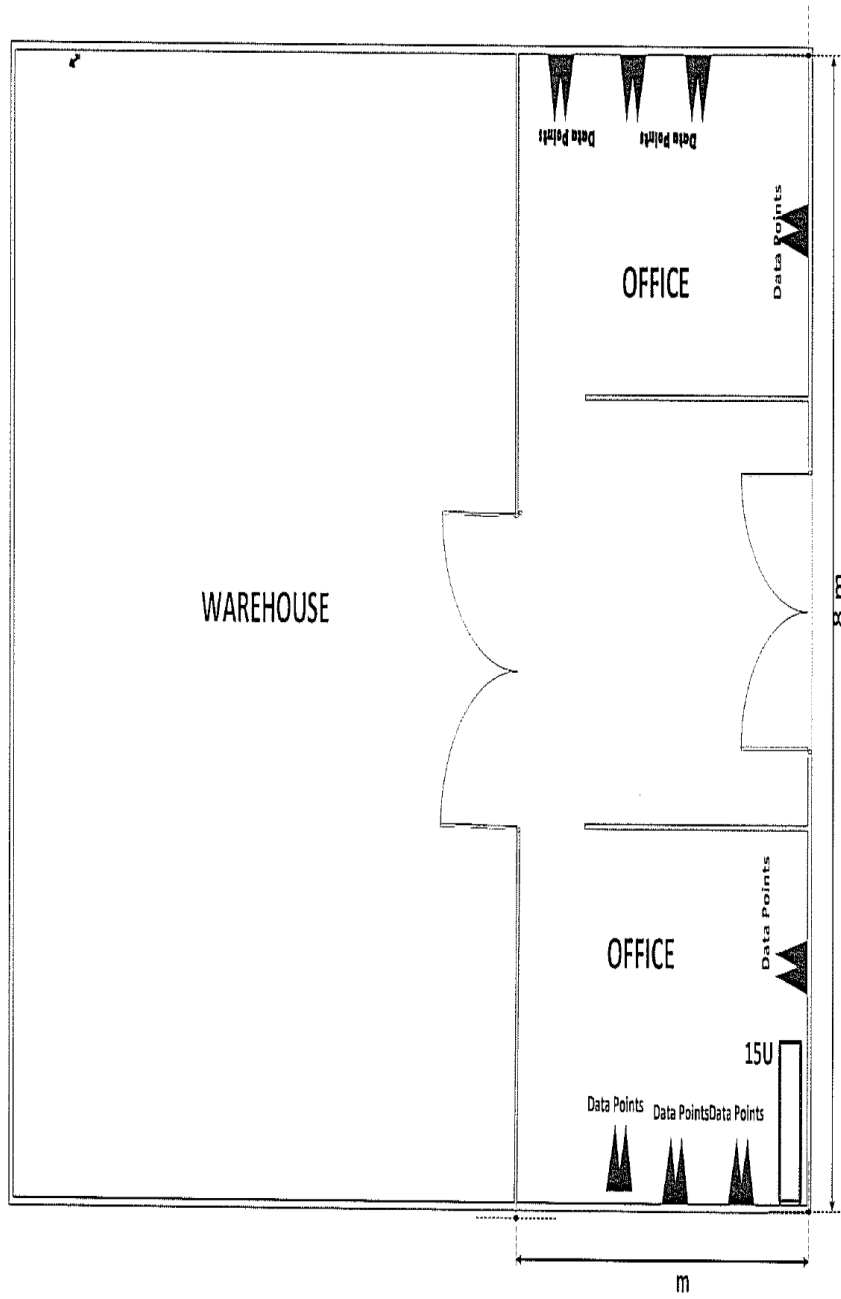

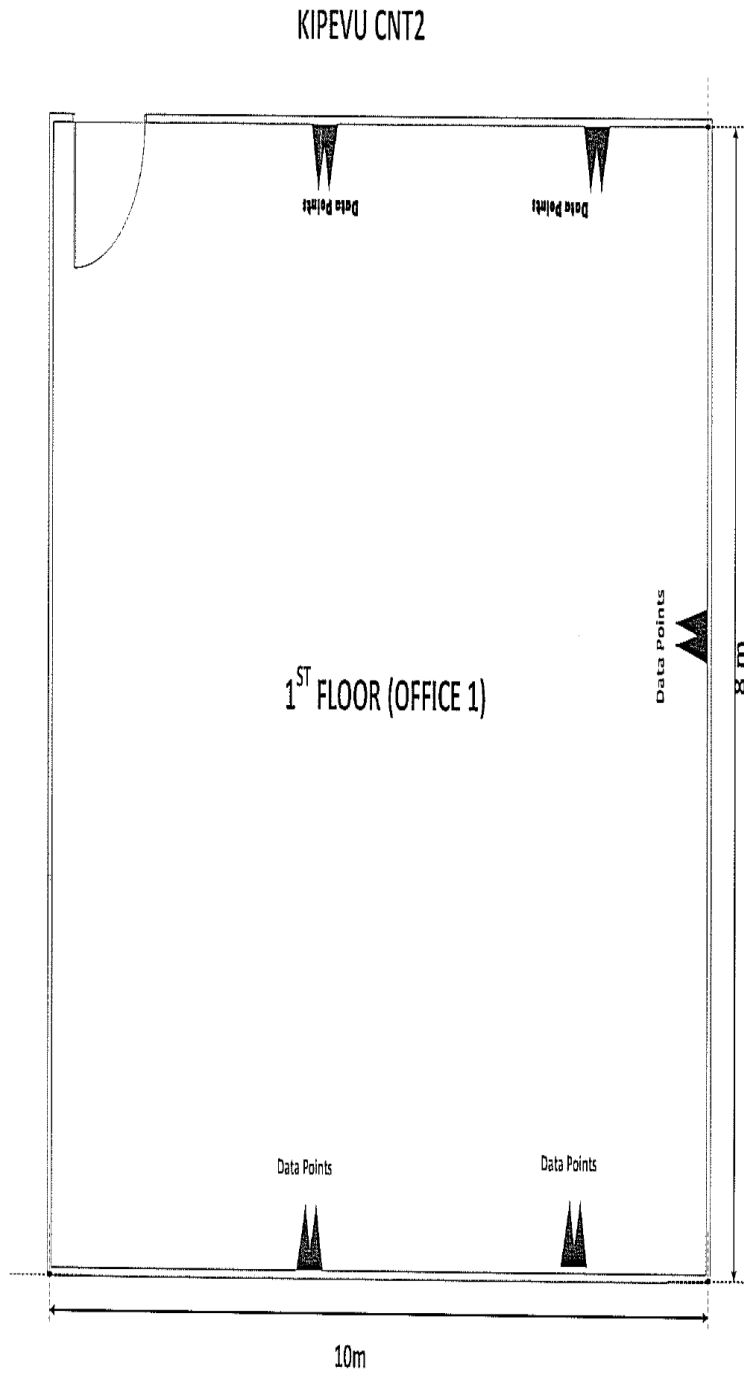

KIPEVU CNT2

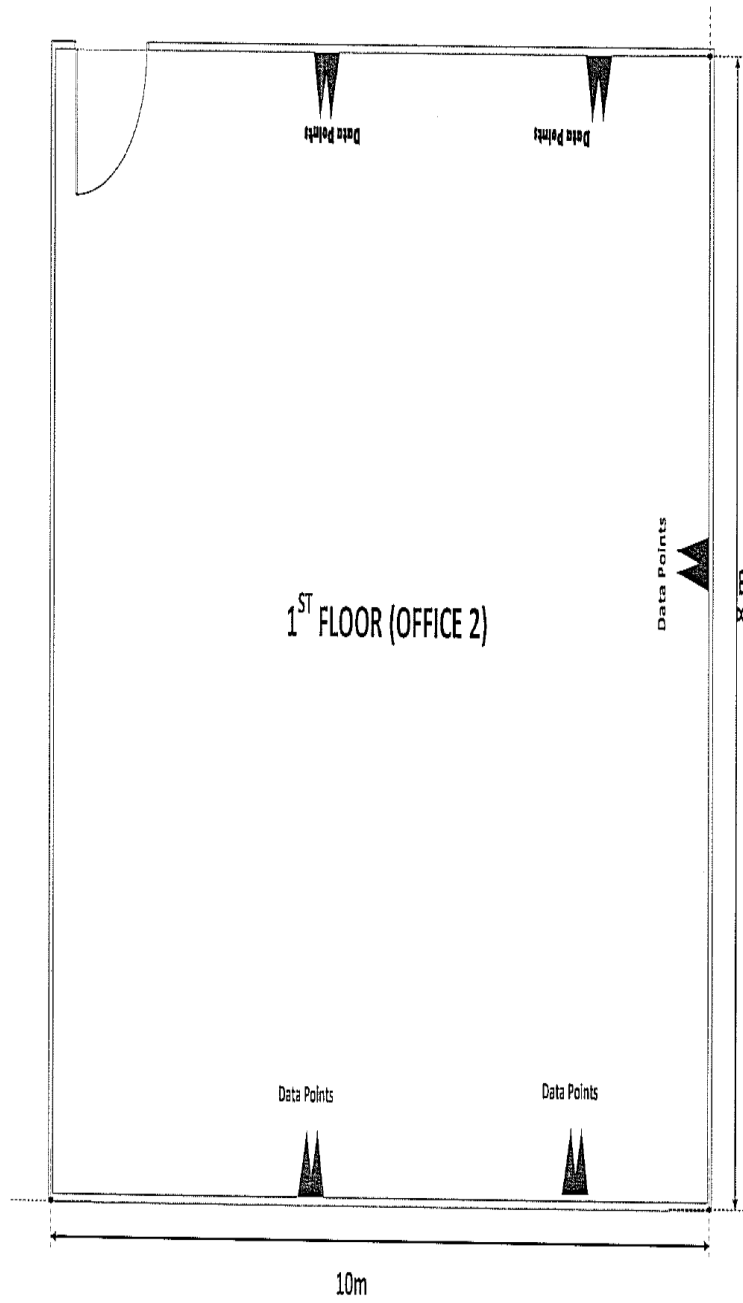

B. Proposed Kilindini Fiber Optic Network Schematic Diagrams

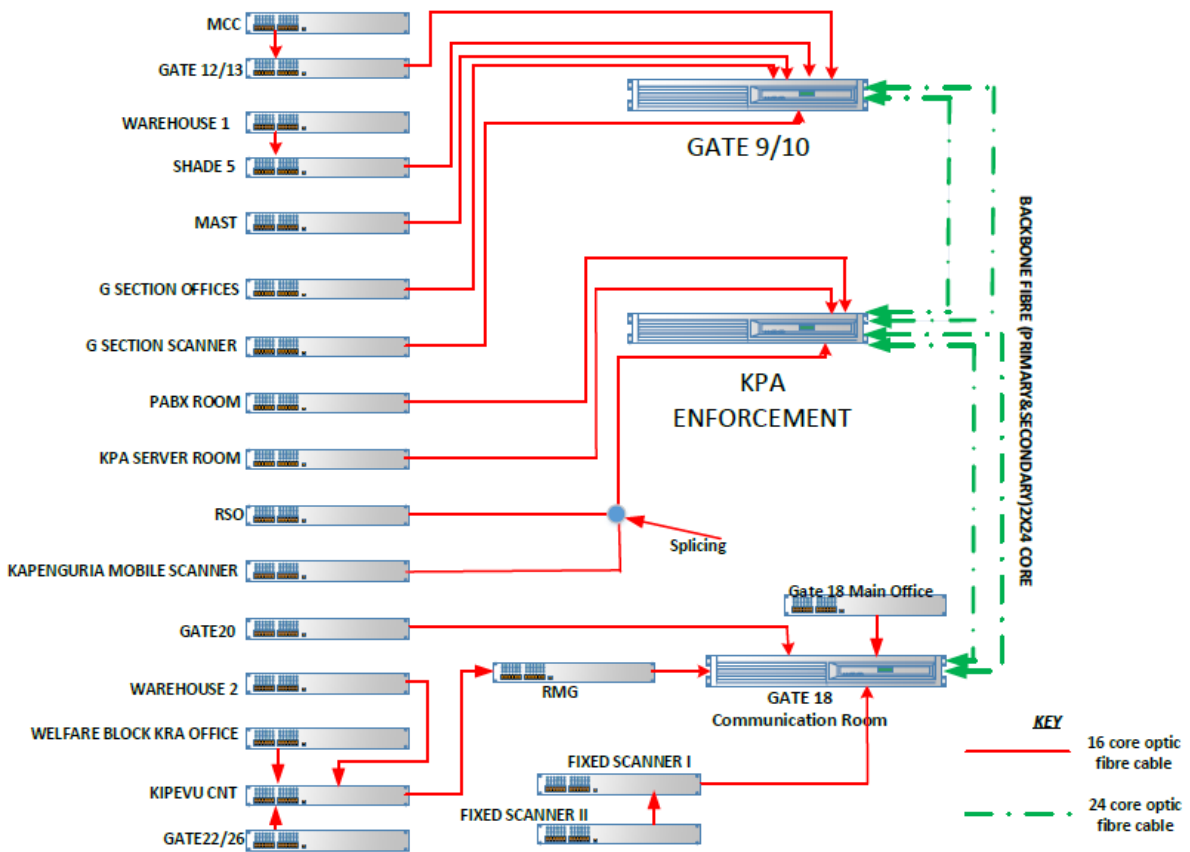

Section VII. Sample Forms

Notes to Bidders on working with the Sample Forms

The Purchaser has prepared the forms in this section of the Bidding Documents to suit the specific requirements of the System being procured. They are derived from the forms contained in the World Bank's Standard Bidding Documents for the Supply and Installation of Information Systems. In its bid, the Bidder must use these forms (or forms that present in the same sequence substantially the same information). Bidders should not introduce changes without the Purchaser's prior written consent (which may also require the clearance of the World Bank). If the Bidder has a question regarding the meaning or appropriateness of the contents or format of the forms and/or the instructions contained in them, these questions should be brought to the Purchaser's attention as soon as possible during the bid clarification process, either at the pre-bid meeting or by addressing them to the Purchaser in writing pursuant to ITB Clause 10.

The Purchaser has tried to provide explanatory text and instructions to help the Bidder prepare the forms accurately and completely. The instructions that appear directly on the forms themselves are indicated by use of typographical aides such as italicized text within square brackets as is shown in the following example taken from the Bid Submission Form:

Duly authorized to sign this bid for and on behalf of [*insert: name of Bidder*]

In preparing its bid, the Bidder must ensure all such information is provided and that the typographical aides are removed.

The sample forms provide a standard set of documents that support the procurement process as it moves forward from the stage of bidding, through Contract formation and onto Contract performance. The first set of forms must be completed and submitted as part of the bid prior to the deadline for bid submission. These include: (i) the Bid Submission Form; (ii) the Price Schedules; (iii) the Manufacturer's Authorizations and key Subcontractor agreements; (iv) the List of Proposed Subcontractors; (v) the form(s) for securing the bid (if and as required); and other forms as found in sub-sections 1 through 4 of this Section VII of the Bidding Documents.

- **Bid Submission Form:** In addition to being the place where official confirmation of the bid price, the currency breakdown, the completion date(s), and other important Contract details are expressed, the Bid Submission Form is also used by the Bidder to confirm - in case adjudication applies in this Contract - its acceptance of the Purchaser's proposed Adjudicator, or to propose an alternative. If the bid is being submitted on behalf of a Joint Venture, it is essential that the Bid Submission Form be signed by the partner in charge and that it be supported by the authorizations and power of attorney required pursuant to ITB Clause 6.2. Given widespread concern about illegal use of licensed software, Bidders will be asked to certify in the Bid Submission Form that either the Software included in the bid was developed and is owned by the Bidder, or, if not, the Software is covered by valid licenses with the proprietor of the Software.

- **Price Schedules:** The prices quoted in the Price Schedules should constitute full and fair compensation for supply, installation, and achieving Operational Acceptance of the System as described in the Technical Requirements based on the Implementation Schedule, and the terms and conditions of the proposed Contract as set forth in the Bidding Documents. Prices should be given for each line item provided in the Schedules, with costs carefully aggregated first at the Subsystem level and then for the entire System. If the Price Schedules provide only a summary breakdown of items and components, or do not cover some items unique to the Bidder's specific technical solution, the Bidder may extend the Schedules to capture those items or components. If supporting price and cost tables are needed for a full understanding of the bid, they should be included.

Arithmetical errors should be avoided. If they occur, the Purchaser will correct them according to ITB Clause 26.2 (ITB Clause 38.2 in the two-stage SBD) without consulting the Bidder. Major omissions, inconsistencies, or lack of substantiating detail can lead to rejection of a bid for commercial non-responsiveness. Presenting prices according to the breakdown prescribed in the Price Schedules is also essential for another reason. If a bid does not separate prices in the prescribed way, and, as a result, the Purchaser cannot apply the domestic preference provision described in ITB Clause 29 (ITB Clause 41 in the two-stage SBD), if they are applicable in this bidding, the Bidder will lose the benefit of the preference. Once bids are opened, none of these problems can be rectified. At that stage, Bidders are not permitted to change their bid prices to overcome errors or omissions.

- **Manufacturer's Authorizations and written agreements by key Subcontractors:** In accordance with ITB Clauses 6.1 (b) and (c), a Bidder may be required to submit, as part of its bid, Manufacturer's Authorizations in the format provided in the Bidding Documents, and agreements by Subcontractors proposed for key services, for all items specified in the Bid Data Sheet. There is no particular format (or sample form) for Subcontractor agreements.
- **List of Proposed Subcontractors:** In accordance with ITB Clause 6.3, a Bidder must submit, as part of its bid, a list of proposed subcontracts for major items of Technologies, Goods, and/or Services. The list should also include the names and places of registration of the Subcontractors proposed for each item and a summary of their qualifications.
- **List of Software and Materials:** In accordance with ITB Clause 13.1 (e) (vi) (ITB Clauses 13.1 (c) (vi) and 25.1 (e) (vi) in the two-stage SBD), Bidders must submit, as part of their bids, lists of all the Software included in the bid assigned to one of the following categories: (A) System, General-Purpose, or Application Software; or (B) Standard or Custom Software. Bidders must also submit a list of all Custom Materials. If provided for in the Bid Data Sheet, the Purchaser may reserve the right to reassign certain key Software to a different category.
- **Qualification information forms:** In accordance with ITB Clause 6, the Purchaser will determine whether the Bidder is qualified to undertake the Contract. This entails financial, technical as well as performance history criteria which are specified in the BDS for ITB Clause 6. The Bidder must provide the necessary information for the

Purchaser to make this assessment through the forms in this sub-section. The forms contain additional detailed instructions which the Bidder must follow.

- **Securing the bid:** If the BDS for ITB Clause 17 (ITB Clause 29 in the two-stage SBD) requires that bids be secured, the Bidder shall do so in accordance with the type and details specified in the same ITB/BDS Clause, either using the form(s) included in these Sample Forms or using another form acceptable to the Purchaser. If a Bidder wishes to use an alternative form, it should ensure that the revised format provides substantially the same protection as the standard format; failing that, the Bidder runs the risk of rejection for commercial non-responsiveness.

Bidders need not provide the Performance Security and Advance Payment Security with their bids. Only the Bidder selected for award by the Purchaser will be required to provide these securities.

The following forms are to be completed and submitted by the successful Bidder following notification of award: (i) Contract Agreement, with all Appendices; (ii) Performance Security; and (iii) Advance Payment Security.

- **Contract Agreement:** In addition to specifying the parties and the Contract Price, the Contract Agreement is where the: (i) Supplier Representative; (ii) if applicable, agreed Adjudicator and his/her compensation; and (iii) the List of Approved Subcontractors are specified. In addition, modifications to the successful Bidder's Bid Price Schedules are attached to the Agreement. These contain corrections and adjustments to the Supplier's bid prices to correct errors, adjust the Contract Price to reflect – if applicable - any extensions to bid validity beyond the last day of original bid validity plus 56 days, etc.
- **Performance Security:** Pursuant to GCC Clause 13.3, the successful Bidder is required to provide the Performance Security in the form contained in this section of these Bidding Documents and in the amount specified in accordance with the SCC.
- **Advance Payment Security:** Pursuant to GCC Clause 13.2, the successful Bidder is required to provide a bank guarantee for the full amount of the Advance Payment - if an Advance Payment is specified in the SCC for GCC 12.1 - in the form contained in this section of these Bidding Documents or another form acceptable to the Purchaser. If a Bidder wishes to propose a different Advance Payment Security form, it should submit a copy to the Purchaser promptly for review and confirmation of acceptability before the bid submission deadline.

The Purchaser and Supplier will use the following additional forms during Contract implementation to formalize or certify important Contract events: (i) the Installation and Operational Acceptance Certificates; and (ii) the various Change Order forms. These and the procedures for their use during performance of the Contract are included in the Bidding Documents for the information of Bidders.

Table of Sample Forms

1. Bid Submission Form (Single-Stage Bidding)	239
2. Price Schedule Forms	243
2.1 Preamble	244
2.2 Grand Summary Cost Table.....	245
2.3 Supply and Installation Cost Summary Table	246
3. Other Bid Forms and Lists	254
3.1 Manufacturer’s Authorization.....	255
3.2 Software List.....	256
3.3 List of Custom Materials	257
3.4.1 General Information Form	258
3.4.2 General Information Systems Experience Record.....	259
3.4.2a Joint Venture Summary.....	260
3.4.3 Particular Information Systems Experience Record.....	261
3.4.3a Details of Contracts of Similar Nature and Complexity	262
3.4.4 Summary Sheet: Current Contract Commitments / Work in Progress	263
3.4.5 Financial Capabilities.....	264
3.4.6 Personnel Capabilities.....	266
3.4.6a Candidate Summary	267
3.4.7 Technical Capabilities.....	268
3.4.8 Litigation History.....	269
4A. Bid Security (Bank Guarantee)	270
4B. Bid Security (Bid Bond)	272
5. Contract Agreement	273
Appendix 1. Supplier’s Representative.....	277
Appendix 2. Adjudicator.....	278
Appendix 3. Categories of Software	279
Appendix 4. Custom Materials	280
Appendix 5. Revised Price Schedules	281
Appendix 6. Minutes of Contract Finalization Discussions and Agreed-to Contract Amendments	282
6. Performance and Advance Payment Security Forms	283
6.1 Performance Security Form (Bank Guarantee).....	284
6.2 Advance Payment Security Form (Bank Guarantee).....	285
7. Installation and Acceptance Certificates	286
7.1 Installation Certificate.....	287
7.2 Operational Acceptance Certificate	288
8. Change Order Procedures and Forms	289
8.1 Request for Change Proposal Form	290

8.2	Change Estimate Proposal Form.....	292
8.3	Estimate Acceptance Form	294
8.4	Change Proposal Form.....	296
8.5	Change Order Form	298
8.6	Application for Change Proposal Form	300

1. BID SUBMISSION FORM (SINGLE-STAGE BIDDING)

Date: *[Bidder insert: date of bid]*

Loan/Credit No.: **5638-KE**

IFB: **KE-KRA-102514-GO-RFB**

Contract: **KE-KRA-102514-GO-RFB IMPROVEMENT OF KRA ICT
CONNECTIVITY INFRASTRUCTURE AT KILINDINI PORT**

To: **KENYA REVENUE AUTHORITY**

P.O. BOX 48240-00100, NAIROBI

Dear Sir or Madam:

Having examined the Bidding Documents, including Addenda Nos *[insert numbers]*, the receipt of which is hereby acknowledged, we, the undersigned, offer to supply, install, achieve Operational Acceptance of, and support the Information System under the above-named Contract in full conformity with the said Bidding Documents for the sum of:

	<i>[insert: amount of local currency in words]</i>	<i>([insert: amount of local currency in figures from corresponding Grand Total entry of the Grand Summary Cost Table])</i>
plus	<i>[insert: amount of foreign currency A in words]</i>	<i>([insert: amount of foreign currency A in figures from corresponding Grand Total entry of the Grand Summary Cost Table])</i>
	<i>[as appropriate, add the following]</i>	
plus	<i>[insert: amount of foreign currency B in words]</i>	<i>([insert: amount of foreign currency B in figures from corresponding Grand Total entry of the Grand Summary Cost Table])</i>
plus	<i>[insert: amount of foreign currency C in words]</i>	<i>([insert: amount of foreign currency C in figures from corresponding Grand Total entry of the Grand Summary Cost Table])</i>

or such other sums as may be determined in accordance with the terms and conditions of the Contract. The above amounts are in accordance with the Price Schedules attached herewith and made part of this bid.

We undertake, if our bid is accepted, to commence work on the Information System and to achieve Installation and Operational Acceptance within the respective times stated in the Bidding Documents.

If our bid is accepted, and if these Bidding Documents so require, we undertake to provide an advance payment security and a performance security in the form, in the amounts, and within the times specified in the Bidding Documents.

We hereby certify that the Solution offered in this bid and to be supplied under the Contract (i) either is owned by us, or (ii) if not owned by us, is covered by a valid license from the proprietor of the Software.

We agree to abide by this bid, which, in accordance with ITB Clauses 13 and 16, consists of this letter (Bid Submission Form) and the enclosures listed below, for a period of **Three Hundred and Sixty Five** days from the date fixed for submission of bids as stipulated in the Bidding Documents, and it shall remain binding upon us and may be accepted by you at any time before the expiration of that period.

Commissions or gratuities, if any, paid or to be paid by us to agents relating to this Bid, and to Contract execution if we are awarded the Contract, are listed below:

Name and Address of Agent	Amount and Currency	Purpose of Commission or Gratuity
------------------------------	---------------------------	---

Etc. *[if none, state: "none"]*

Until the formal final Contract is prepared and executed between us, this bid, together with your written acceptance of the bid and your notification of award, shall constitute a binding contract between us. We understand that you are not bound to accept the lowest or any bid you may receive.

Dated this *[insert: **ordinal**]* day of *[insert: **month**]*, *[insert: **year**]*.

Signed:

Date:

In the capacity of *[insert: **title or position**]*

Duly authorized to sign this bid for and on behalf of *[insert: **name of Bidder**]*

ENCLOSURES:

Price Schedules

Bid-Securing Declaration or Bid-Security (if and as required)

Signature Authorization *[plus, in the case of a Joint Venture Bidder, list all other authorizations pursuant to ITB Clause 6.2]*

Attachment 1. Bidder's Eligibility

Attachment 2. Bidder's Qualifications (including Manufacturer's Authorizations and Subcontractor agreements if and as required)

Attachment 3. Eligibility of Goods and Services

Attachment 4. Conformity of the Information System to the Bidding Documents

Attachment 5. Intellectual Property (Software and Materials Lists)

[if appropriate, specify further attachments or other enclosures]

Bid Table of Contents and Checklist

Note: Bidders should expand and (if appropriate) modify and complete the following table. The purpose of the table is to provide the Bidder with a summary checklist of items that must be included in the bid as described in ITB Clauses 13.1 and 16, in order for the bid to be considered for Contract award. The table also provides a summary page reference scheme to ease and speed the Purchaser’s bid evaluation process.

Item	present: y/n	page no.
Bid Submission Form.....		
Price Schedules		
Bid-Security		
Signature Authorization (for Joint Ventures additionally including the authorizations listed in ITB Clause 6.2)....		
Attachment 1		
Attachment 2		
Manufacturer’s Authorizations		
Attachment 3		
Attachment 4		
Attachment 5		
Attachment 6		
.....		

2. PRICE SCHEDULE FORMS

2.1 Preamble

General

1. The Price Schedules are divided into separate Schedules as follows:
 - 2.2 Grand Summary Cost Table
 - 2.3 Supply and Installation Cost Summary Table
 - 2.4 Recurrent Cost Summary Table
 - 2.5 Supply and Installation Cost Sub-Table(s)
 - 2.6 Recurrent Cost Sub-Tables(s)
 - 2.7 Country of Origin Code Table
2. The Schedules do not generally give a full description of the information technologies to be supplied, installed, and operationally accepted, or the Services to be performed under each item. However, it is assumed that Bidders shall have read the Technical Requirements and other sections of these Bidding Documents to ascertain the full scope of the requirements associated with each item prior to filling in the rates and prices. The quoted rates and prices shall be deemed to cover the full scope of these Technical Requirements, as well as overhead and profit.
3. If Bidders are unclear or uncertain as to the scope of any item, they shall seek clarification in accordance with the Instructions to Bidders in the Bidding Documents prior to submitting their bid.

Pricing

4. Prices shall be filled in indelible ink, and any alterations necessary due to errors, etc., shall be initialed by the Bidder. As specified in the Bid Data Sheet, prices shall be fixed and firm for the duration of the Contract.
5. Bid prices shall be quoted in the manner indicated and in the currencies specified in ITB Clauses 14 and 15 (ITB Clauses 27 and 28 in the two-stage SBD). Prices must correspond to items of the scope and quality defined in the Technical Requirements or elsewhere in these Bidding Documents.
6. The Bidder must exercise great care in preparing its calculations, since there is no opportunity to correct errors once the deadline for submission of bids has passed. A single error in specifying a unit price can therefore change a Bidder's overall total bid price substantially, make the bid noncompetitive, or subject the Bidder to possible loss. The Purchaser will correct any arithmetic error in accordance with the provisions of ITB Clause 26.2 (ITB Clause 38.2 in the two-stage SBD).
7. Payments will be made to the Supplier in the currency or currencies indicated under each respective item. As specified in ITB Clause 15.1 (ITB Clause 28.1 in the two-stage SBD), no more than three foreign currencies may be used. The price of an item should be unique regardless of installation site.

2.2 Grand Summary Cost Table

		<i>[insert: Local Currency]</i> Price	<i>[insert: Foreign Currency A]</i> Price	<i>[insert: Foreign Currency B]</i> Price	<i>[insert: Foreign Currency C]</i> Price
LOT 1	DESIGN, SUPPLY, INSTALLATION, CONFIGURATION AND COMMISSIONING OF A FIBER OPTIC BASED METROPOLITAN AREA NETWORK (MAN) AND LOCAL AREA NETWORKS (LANs) IN KILINDINI PORT.				
LOT 2	DESIGN, SUPPLY, INSTALLATION, CONFIGURATION AND COMMISSIONING OF AN ENTERPRISE NETWORK MANAGEMENT AND WAN OPTIMISATION SOLUTION				
3.	Grand Totals (to Bid Submission Form)				

Name of Bidder:	
Authorized Signature of Bidder:	

2.3 Supply and Installation Cost Summary Table

LOT I: DESIGN, SUPPLY, INSTALLATION, CONFIGURATION AND COMMISSIONING OF A FIBER OPTIC BASED METROPOLITAN AREA NETWORK (MAN) AND LOCAL AREA NETWORKS (LANs) IN KILINDINI PORT.

Costs must reflect prices and rates quoted in accordance with ITB Clauses 14 and 15 (ITB Clauses 27 and 28 in the two-stage SBD).

Note:

1. For items marked *, the specific quantities required are to be established during the bidders' mandatory site survey visit.
2. Bidders are to list and quote for any other items that they determine necessary a fully functional Network.

Line Item No.	Item Description	Quantity	Supply and Installation Cost Sub-Table No.	Locally supplied items	Items supplied from outside the Purchaser's Country			
				[insert: Local Currency] Price –KES.	[insert: Local Currency] Price	[insert: Foreign Currency A] Price	[insert: Foreign Currency B] Price	[insert: Foreign Currency C] Price
1	Work Area subsystem							
(a)	Cat 6a Dual Modules and outlet	400						
(b)	Cat 6a patch cords 5 meters	800						
2	Horizontal subsystem							
(a)	Cat 6a cable	150 Rolls (Standard 305 meters)						
(b)	Cat 6a Outdoor UTP cable	20 Rolls (Standard 305 meters)						
3	Pathway subsystem							

				Locally supplied items	Items supplied from outside the Purchaser's Country			
Line Item No.	Item Description	Quantity	Supply and Installation Cost Sub- Table No.	<i>[insert: Local Currency] Price –KES.</i>	<i>[insert: Local Currency] Price</i>	<i>[insert: Foreign Currency A] Price</i>	<i>[insert: Foreign Currency B] Price</i>	<i>[insert: Foreign Currency C] Price</i>
(a)	Heavy Duty Outdoor PVC Conduits	*						
(b)	250mm by 50mm metal trunking	*						
4	Back bone subsystem							
(a)	24 Core Armored Single-Mode Fiber optic (outdoor)	*						
(b)	16 Core Armored Single-Mode Fiber optic (outdoor)	*						
(c)	16 Core Multi- Mode Fiber optic (indoor)	*						
5	Administration subsystem							
(a)	Cat6a 48 port patch panel	10						
(b)	Cat6a 24 port patch panel	12						
(c)	Cat6a 12 port patch panel	12						
(d)	Fiber 12 way patch panel	65						

				Locally supplied items	Items supplied from outside the Purchaser's Country			
Line Item No.	Item Description	Quantity	Supply and Installation Cost Sub-Table No.	<i>[insert: Local Currency]</i> Price –KES.	<i>[insert: Local Currency]</i> Price	<i>[insert: Foreign Currency A]</i> Price	<i>[insert: Foreign Currency B]</i> Price	<i>[insert: Foreign Currency C]</i> Price
(e)	Cat6a 1meter patch cord	800						
(f)	Fiber patch cord 10meter	20						
(g)	Fiber patch cord 3meter	30						
(h)	Accessories e.g. Wall Clips, Pigtails etc.	*						
(i)	Fiber patch cord 1meter	140						
(j)	Cable manager	45						
(k)	42u cabinets (Free standing)	5						
(l)	32u cabinets (Free standing)	15						
(m)	15u cabinets (Wall Mount)	10						
(n)	1500 VA Rack Mountable UPS	30						
6	Active devices							
(a)	48 Port Switch	15						
(b)	24 Port Switch	25						
(c)	24 Port Fiber Switch	10						
(d)	Branch Router	30						

				Locally supplied items	Items supplied from outside the Purchaser's Country			
Line Item No.	Item Description	Quantity	Supply and Installation Cost Sub-Table No.	<i>[insert: Local Currency]</i> Price –KES.	<i>[insert: Local Currency]</i> Price	<i>[insert: Foreign Currency A]</i> Price	<i>[insert: Foreign Currency B]</i> Price	<i>[insert: Foreign Currency C]</i> Price
	Provisional Sum			12,000,000.00				
SUBTOTALS								
TOTAL (To Grand Summary Table)								

Name of Bidder:		
Authorized Signature of Bidder:		

**LOT 2: DESIGN, SUPPLY, INSTALLATION, CONFIGURATION AND COMMISSIONING
OF AN ENTERPRISE NETWORK MANAGEMENT AND WAN OPTIMISATION
SOLUTION**

Costs must reflect prices and rates quoted in accordance with ITB Clauses 14 and 15 (ITB Clauses 27 and 28 in the two-stage SBD).

Note: 1. Bidders are to list and quote for any other items that they determine necessary a fully functional Solution.

Line Item No.	Item	Quantity	Supply and Installation Cost Sub-Table No.	Locally supplied items	Items supplied from outside the Purchaser's Country			
				[insert: Local Currency] Price	[insert: Foreign Currency A] Price	[insert: Foreign Currency B] Price	[insert: Foreign Currency C] Price	
1	Overall design of an enterprise Network Management and WAN optimization Solution	1						
2	Supply, Installation and Configuration of a WAN Optimization Solution for Two(2) Data Centers (Hardware and software)	2						

Line Item No.	Item	Quantity	Supply and Installation Cost Sub-Table No.	Locally supplied items	Items supplied from outside the Purchaser's Country				
				[insert: Local Currency] Price	[insert: Local Currency] Price	[insert: Foreign Currency A] Price	[insert: Foreign Currency B] Price	[insert: Foreign Currency C] Price	
3	Supply, Installation and Configuration of a WAN optimization Solution for Ten(10) medium Branch Station (Hardware and software)	10							
4	Supply, Installation and Configuration of a centralized management solution (for items 1,2,3 above) at the Data centers (Hardware and software)	2							
5	Installation, Configuration, integration and user training for the overall solution	1							

				Locally supplied items	Items supplied from outside the Purchaser's Country			
Line Item No.	Item	Quantity	Supply and Installation Cost Sub-Table No.	<i>[insert: Local Currency]</i> Price	<i>[insert: Local Currency]</i> Price	<i>[insert: Foreign Currency A]</i> Price	<i>[insert: Foreign Currency B]</i> Price	<i>[insert: Foreign Currency C]</i> Price
	List and quote for any other items that the bidder determines necessary for a fully functional network.							
SUBTOTALS								
TOTAL (To Grand Summary Table)								

Name of Bidder:		
Authorized Signature of Bidder:		

3. OTHER BID FORMS AND LISTS

3.1 Manufacturer’s Authorization

Invitation for Bids Title and No.:
[If applicable:] Lot, Slice, Subsystem No(s):

To: _____

WHEREAS _____ who are official producers of
_____ and having production facilities at
_____ do hereby authorize
_____ located at
_____ (hereinafter, the “Bidder”)
to submit a bid and subsequently negotiate and sign a Contract with you for resale of the
following Products produced by us:

We hereby confirm that, in case the bidding results in a Contract between you and the Bidder,
the above-listed products will come with our full standard warranty.

Name _____ In the capacity of _____

Signed _____

Duly authorized to sign the authorization for and on behalf of : _____

Dated on _____ day of _____, _____.

Note: This authorization should be written on the letterhead of the Manufacturer and be signed by a person with the proper authority to sign documents that are binding on the Manufacturer.

3.4.1 General Information Form

All individual firms and each partner of a Joint Venture that are bidding must complete the information in this form. Nationality information should be provided for all owners or Bidders that are partnerships or individually owned firms.

Where the Bidder proposes to use named Subcontractors for highly specialized components of the Information System, the following information should also be supplied for the Subcontractor(s), together with the information in Forms 3.5.2, 3.5.3, 3.5.3a, 3.5.4, and 3.5.5. Joint Ventures must also fill out Form 3.5.2a.

1.	Name of firm	
2.	Head office address	
3.	Telephone	Contact
4.	Fax	Telex
5.	Place of incorporation / registration	Year of incorporation / registration

Nationality of owners ¹		
	Name	Nationality
1.		
2.		
3.		
4.		
5.		
^{1/} To be completed by all owners of partnerships or individually owned firms.		

3.4.2 General Information Systems Experience Record

Name of Bidder or partner of a Joint Venture
--

All individual firms and all partners of a Joint Venture must complete the information in this form with regard to the management of Information Systems contracts generally. The information supplied should be the annual turnover of the Bidder (or each member of a Joint Venture), in terms of the amounts billed to clients for each year for work in progress or completed, converted to U.S. dollars at the rate of exchange at the end of the period reported. The annual periods should be calendar years, with partial accounting for the year up to the date of submission of applications. This form may be included for Subcontractors only if the Bid Data Sheet for ITB Clause 6.1 (a) explicitly permits experience and resources of (certain) Subcontractors to contribute to the Bidder's qualifications.

A brief note on each contract should be appended, describing the nature of the Information System, duration and amount of contract, managerial arrangements, purchaser, and other relevant details.

Use a separate page for each partner of a Joint Venture, and number these pages.

Bidders should not enclose testimonials, certificates, and publicity material with their applications; they will not be taken into account in the evaluation of qualifications.

Annual turnover data (applicable activities only)		
Year ¹	Turnover	US\$ equivalent
1.		
2.		
3.		
4.		
5.		
¹ / Commencing with the partial year up to the date of submission of bids		

3.4.2a Joint Venture Summary

Names of all partners of a Joint Venture
1. Partner in charge
2. Partner
3. Partner
4. Partner
5. Partner
6. etc.

Total value of annual turnover, in terms of Information System billed to clients, in US\$ equivalent, converted at the rate of exchange at the end of the period reported:

Annual turnover data (applicable activities only; US\$ equivalent)						
Partner	Form 3.5.2 page no.	Year 1	Year 2	Year 3	Year 4	Year 5
1. Partner in charge						
2. Partner						
3. Partner						
4. Partner						
5. Partner						
6. Etc.						
Totals						

3.4.3 Particular Information Systems Experience Record

Name of Bidder or partner of a Joint Venture
--

On separate pages, using the format of Form 3.5.3a, the Bidder is requested to list contracts of a similar nature, complexity, and requiring similar information technology and methodologies to the contract or contracts for which these Bidding Documents are issued, and which the Bidder has undertaken during the period, and of the number, specified in the BDS for ITB Clause 6.1 (a). Each partner of a Joint Venture should separately provide details of its own relevant contracts. The contract value should be based on the payment currencies of the contracts converted into U.S. dollars, at the date of substantial completion, or for ongoing contracts at the time of award.

3.4.3a Details of Contracts of Similar Nature and Complexity

Name of Bidder or partner of a Joint Venture
--

Use a separate sheet for each contract.

1.	Number of contract	
	Name of contract	
	Country	
2.	Name of Purchaser	
3.	Purchaser address	
4.	Nature of Information Systems and special features relevant to the contract for which the Bidding Documents are issued	
5.	Contract role (check one) <input type="checkbox"/> Prime Supplier <input type="checkbox"/> Management Contractor <input type="checkbox"/> Subcontractor <input type="checkbox"/> Partner in a Joint Venture	
6.	Amount of the total contract/subcontract/partner share (in specified currencies at completion, or at date of award for current contracts) Currency Currency Currency	
7.	Equivalent amount US\$ Total contract: \$_____ ; Subcontract: \$_____ ; Partner share: \$_____ ;	
8.	Date of award/completion	
9.	Contract was completed _____ months ahead/behind original schedule (if behind, provide explanation).	
10.	Contract was completed US\$ _____ equivalent under/over original contract amount (if over, provide explanation).	
11.	Special contractual/technical requirements.	
12.	Indicate the approximate percent of total contract value (and US\$ amount) of Information System undertaken by subcontract, if any, and the nature of such Information System.	

3.4.4 Summary Sheet: Current Contract Commitments / Work in Progress

Name of Bidder or partner of a Joint Venture
--

Bidders and each partner to an Joint Venture bid should provide information on their current commitments on all contracts that have been awarded, or for which a letter of intent or acceptance has been received, or for contracts approaching completion, but for which an unqualified, full completion certificate has yet to be issued.

Name of contract	Purchaser, contact address/tel./fax	Value of outstanding Information System (current US\$ equivalent)	Estimated completion date	Average monthly invoicing over last six months (US\$/month)
1.				
2.				
3.				
4.				
5.				
etc.				

3.4.5 Financial Capabilities

Name of Bidder or partner of a Joint Venture
--

Bidders, including each partner of a Joint Venture, shall provide financial information to demonstrate that they meet the requirements stated in the BDS for ITB Clause 6.1 (a). Each Bidder or partner of a Joint Venture shall complete this form. If necessary, separate sheets shall be used to provide complete banker information. A copy of the audited balance sheets shall be attached.

Autonomous subdivisions of parent conglomerate businesses shall submit financial information related only to the particular activities of the subdivision.

Banker	Name of banker		
	Address of banker		
	Telephone	Contact name and title	
	Fax	Telex	

Summarize actual assets and liabilities in U.S. dollar equivalent (at the rates of exchange current at the end of each year) for the previous five calendar years. Based upon known commitments, summarize projected assets and liabilities in U.S. dollar equivalent for the next two calendar years, unless the withholding of such information by stock market listed public companies can be substantiated by the Bidder.

Financial information in US\$ equivalent	Actual: Previous five years					Projected: Next two years	
	5	4	3	2	1	1	2
1. Total assets							
2. Current assets							
3. Total liabilities							
4. Current liabilities							
5. Profits before taxes							
6. Profits after taxes							

Specify proposed sources of financing, such as liquid assets, unencumbered real assets, lines of credit, and other financial means, net of current commitments, available to meet the total

construction cash flow demands of the subject contract or contracts as indicated in the BDS for ITB Clause 6.1 (a).

Source of financing	Amount (US\$ equivalent)
1.	
2.	
3.	
4.	

Attach audited financial statements—including, as a minimum, profit and loss account, balance sheet, and explanatory notes—for the period stated in the BDS for ITB Clause 6.1 (a) (for the individual Bidder or each partner of a Joint Venture).

If audits are not required by the laws of Bidders' countries of origin, partnerships and firms owned by individuals may submit their balance sheets certified by a registered accountant, and supported by copies of tax returns,

3.4.6 Personnel Capabilities

Name of Bidder

For specific positions essential to contract management and implementation (and/or those specified in the Bidding Documents, if any), Bidders should provide the names of at least two candidates qualified to meet the specified requirements stated for each position. The data on their experience should be supplied on separate sheets using one Form 3.5.6a for each candidate.

Bidders may propose alternative management and implementation arrangements requiring different key personnel, whose experience records should be provided.

1.	Title of position
	Name of prime candidate
	Name of alternate candidate
2.	Title of position
	Name of prime candidate
	Name of alternate candidate
3.	Title of position
	Name of prime candidate
	Name of alternate candidate
4.	Title of position
	Name of prime candidate
	Name of alternate candidate

3.4.7 Technical Capabilities

Name of Bidder

The Bidder shall provide adequate information to demonstrate clearly that it has the technical capability to meet the requirements for the Information System. With this form, the Bidder should summarize important certifications, proprietary methodologies, and/or specialized technologies which the Bidder proposes to utilize in the execution of the Contract or Contracts.

4A. BID SECURITY (BANK GUARANTEE)

*[insert: **Bank's Name, and Address of Issuing Branch or Office**]*

Beneficiary: *[insert: **Name and Address of Purchaser**]*

Date: *[insert: **date**]*

BID GUARANTEE No.: *[insert: **Bid Guarantee Number**]*

We have been informed that *[insert: **name of the Bidder**]* (hereinafter called "the Bidder") has submitted to you its bid dated *[insert: **bid date**]* (hereinafter called "the Bid") for the execution of *[insert: **name of contract**]* under Invitation for Bids No. *[insert: **IFB number**]*.

Furthermore, we understand that, according to your conditions, bids must be supported by a bid guarantee, and that the bid guarantee automatically covers any alternative bids included in the Bid, if the Bidder is permitted to offer alternatives and does so.

At the request of the Bidder, we *[insert: **name of Bank**]* hereby irrevocably undertake to pay you any sum or sums not exceeding in total an amount of *[insert: **amount in figures**]* (*[insert: **amount in words**]*) upon receipt by us of your first demand in writing accompanied by a written statement stating that the Bidder is in breach of its obligation(s) under the bid conditions, because the Bidder:

- (a) has withdrawn the Bid (or any parts of it) during the period of bid validity specified by the Bidder in the Bid Submission Form or any extension of the period of bid validity which the Bidder subsequently agreed to; or
- (b) having been notified of the acceptance of the Bid by you during the period of bid validity, (i) failed or refused to execute the Contract Agreement, or (ii) failed or refused to furnish the performance security, if required, in accordance with the Instructions to Bidders.

This guarantee will expire: (a) if the Bidder is the successful bidder, upon our receipt of copies of the contract signed by the Bidder and the performance security issued to you upon the instruction of the Bidder; or (b) if the Bidder is not the successful bidder, upon the earlier of (i) our receipt of a copy of your notification to the Bidder of the name of the successful bidder; or (ii) twenty-eight days after the expiration of the Bid's validity.

Consequently, any demand for payment under this guarantee must be received by us at the office on or before that date.

This guarantee is subject to the Uniform Rules for Demand Guarantees, ICC Publication No. 458.

[Signature(s)]

[Note to Bidders: Instructions on amount and currency can be found in the ITB Clause and BDS for "Securing the Bid." Joint Ventures need to also ensure that their Bank Guarantee meets the requirements for Joint Ventures as provided in the same Clause.]

4B. BID SECURITY (BID BOND)

BOND NO.: _____

BY THIS BOND, [*insert: name of Bidder*] as Principal (hereinafter called "the Principal"), and [*insert: name, legal title, and address of surety*], authorized to transact business in [*insert: name of Purchaser's country*], as Surety (hereinafter called "the Surety"), are held and firmly bound unto [*insert name of Purchaser*] as Obligee (hereinafter called "the Purchaser") in the sum of [*insert amount of Bond in currency, figures and words*], for the payment of which sum, well and truly to be made, we, the said Principal and Surety, bind ourselves, our successors and assigns, jointly and severally, firmly by these presents.

WHEREAS the Principal has submitted a written bid to the Purchaser dated the ____ day of _____, 20__, for the execution of [*insert: name of contract*] (hereinafter called "the Bid"). If the Principal was permitted by the bidding conditions to submit alternative bid(s) and did so, then these are deemed part of the Bid and thus covered by this Bond.

NOW, THEREFORE, THE CONDITION OF THIS OBLIGATION is such that if the Principal:

- (a) withdraws the Bid (or any parts of it) during the period of the Bid's validity specified in the Bid Submission Form, or any extension of the period of the Bid's validity the Principal subsequently agreed to, notice of which to the Surety is hereby waived; or
- (b) having been notified of the acceptance of the Bid by the Purchaser during the period of the Bid's validity, (i) fails or refuses to execute the Contract Agreement, or (ii) fails or refuses to furnish the performance security, if required, in accordance with the Instructions to Bidders;

then the Surety undertakes to immediately pay to the Purchaser up to the above amount upon receipt of the Purchaser's first written demand, without the Purchaser having to substantiate its demand, provided that in its demand the Purchaser shall state that the demand arises from the occurrence of any of the above events, specifying which event(s) has/have occurred.

The Surety hereby agrees that its obligation will remain in full force and effect up to and including the date 28 days after the date of expiration of the Bid's validity.

IN TESTIMONY WHEREOF, the Principal and the Surety have caused these presents to be executed in their respective names this ____ day of _____ 20__.

Principal: _____ Surety: _____

[add Corporate Seal(s) (where appropriate)]

[Signature]

[Signature]

[state: **printed name and title**]

[state: **printed name and title**]

[Note to Bidders: Instructions on amount and currency can be found in the ITB Clause and BDS for "Securing the Bid." Joint Ventures need to also ensure that their Bid Bond meets the requirements for Joint Ventures as provided in the same Clause.]

5. CONTRACT AGREEMENT

THIS CONTRACT AGREEMENT is made

the [*insert: ordinal*] day of [*insert: month*], [*insert: year*].

BETWEEN

- (1) [*insert: Name of Purchaser*], a [*insert: description of type of legal entity, for example, an agency of the Ministry of . . .*] of the Government of [*insert: country of Purchaser*], or corporation incorporated under the laws of [*insert: country of Purchaser*] and having its principal place of business at [*insert: address of Purchaser*] (hereinafter called “the Purchaser”), and
- (2) [*insert: name of Supplier*], a corporation incorporated under the laws of [*insert: country of Supplier*] and having its principal place of business at [*insert: address of Supplier*] (hereinafter called “the Supplier”).

WHEREAS the Purchaser desires to engage the Supplier to supply, install, achieve Operational Acceptance of, and support the following Information System [*insert: brief description of the Information System*] (“the System”), and the Supplier has agreed to such engagement upon and subject to the terms and conditions appearing below in this Contract Agreement.

NOW IT IS HEREBY AGREED as follows:

Article 1.

1.1 Contract Documents (Reference GCC Clause 1.1 (a) (ii))

Contract Documents

The following documents shall constitute the Contract between the Purchaser and the Supplier, and each shall be read and construed as an integral part of the Contract:

- (a) This Contract Agreement and the Appendices attached to the Contract Agreement
- (b) Special Conditions of Contract
- (c) General Conditions of Contract
- (d) Technical Requirements (including Implementation Schedule)
- (e) The Supplier’s bid and original Price Schedules
- (f) [*Add here: any other documents*]

1.2 Order of Precedence (Reference GCC Clause 2)

In the event of any ambiguity or conflict between the Contract Documents listed above, the order of precedence shall be the order in which the Contract Documents are listed in Article 1.1 (Contract Documents) above, provided that Appendix 7 shall prevail over all provisions of the Contract Agreement and the other Appendices attached to the Contract Agreement and all the other Contract Documents listed in Article 1.1 above.

1.3 Definitions (Reference GCC Clause 1)

Capitalized words and phrases used in this Contract Agreement shall have the same meanings as are ascribed to them in the General Conditions of Contract.

Article 2.

**Contract Price
and Terms of
Payment**

2.1 Contract Price (Reference GCC Clause 1.1(a)(viii) and GCC Clause 11)

The Purchaser hereby agrees to pay to the Supplier the Contract Price in consideration of the performance by the Supplier of its obligations under the Contract. The Contract Price shall be the aggregate of: [*insert: amount of foreign currency A in words*], [*insert: amount in figures*], plus [*insert: amount of foreign currency B in words*], [*insert: amount in figures*], plus [*insert: amount of foreign currency C in words*], [*insert: amount in figures*], [*insert: amount of local currency in words*], [*insert: amount in figures*], as specified in the Grand Summary Price Schedule.

The Contract Price shall be understood to reflect the terms and conditions used in the specification of prices in the detailed price schedules, including the terms and conditions of the associated Incoterms, and the taxes, duties and related levies if and as identified.

Article 3.

**Effective Date
for
Determining
Time for
Operational
Acceptance**

3.1 Effective Date (Reference GCC Clause 1.1 (e) (ix))

The time allowed for supply, installation, and achieving Operational Acceptance of the System shall be determined from the date when all of the following conditions have been fulfilled:

- (a) This Contract Agreement has been duly executed for and on behalf of the Purchaser and the Supplier;
- (b) The Supplier has submitted to the Purchaser the performance security and the advance payment security, in accordance with GCC Clause 13.2 and GCC Clause 13.3;
- (c) The Purchaser has paid the Supplier the advance payment, in accordance with GCC Clause 12;

- (d) *[specify here: any other conditions, for example, opening/confirmation of letter of credit].*

Each party shall use its best efforts to fulfill the above conditions for which it is responsible as soon as practicable.

- 3.2 If the conditions listed under 3.1 are not fulfilled within two (2) months from the date of this Contract Agreement because of reasons not attributable to the Supplier, the parties shall discuss and agree on an equitable adjustment to the Contract Price and the Time for Achieving Operational Acceptance and/or other relevant conditions of the Contract.

Article 4.

Appendixes

- 4.1 The Appendixes listed below shall be deemed to form an integral part of this Contract Agreement.
- 4.2 Reference in the Contract to any Appendix shall mean the Appendixes listed below and attached to this Contract Agreement, and the Contract shall be read and construed accordingly.

APPENDIXES

- Appendix 1. Supplier's Representative
- Appendix 2. Adjudicator *[if there is no Adjudicator, state "not applicable"]*
- Appendix 3. List of Approved Subcontractors
- Appendix 4. Categories of Software
- Appendix 5. Custom Materials
- Appendix 6. Revised Price Schedules (if any)
- Appendix 7. Minutes of Contract Finalization Discussions and Agreed-to Contract Amendments

IN WITNESS WHEREOF the Purchaser and the Supplier have caused this Agreement to be duly executed by their duly authorized representatives the day and year first above written.

For and on behalf of the Purchaser

Signed:

in the capacity of [*insert: title or other appropriate designation*]

in the presence of

For and on behalf of the Supplier

Signed:

in the capacity of [*insert: title or other appropriate designation*]

in the presence of

CONTRACT AGREEMENT

dated the [*insert: number*] day of [*insert: month*], [*insert: year*]

BETWEEN

[*insert: name of Purchaser*], “the Purchaser”

and

[*insert: name of Supplier*], “the Supplier”

Appendix 1. Supplier's Representative

In accordance with GCC Clause 1.1 (b) (iv), the Supplier's Representative is:

Name: *[insert: **name** and provide title and address further below, or state “to be nominated within fourteen (14) days of the Effective Date”]*

Title: *[if appropriate, insert: **title**]*

In accordance with GCC Clause 4.3, the Supplier's addresses for notices under the Contract are:

Address of the Supplier's Representative: *[as appropriate, insert: **personal delivery, postal, cable, telegraph, telex, facsimile, electronic mail, and/or EDI addresses.**]*

Fallback address of the Supplier: *[as appropriate, insert: **personal delivery, postal, cable, telegraph, telex, facsimile, electronic mail, and/or EDI addresses.**]*

Appendix 2. Adjudicator

In accordance with GCC Clause 1.1 (b) (vi), the agreed-upon Adjudicator is:

Name: *[insert: name]*

Title: *[insert: title]*

Address: *[insert: postal address]*

Telephone: *[insert: telephone]*

In accordance with GCC Clause 6.1.3, the agreed-upon fees and reimbursable expenses are:

Hourly Fees: *[insert: hourly fees]*

Reimbursable Expenses: *[list: reimbursables]*

Pursuant to GCC Clause 6.1.4, if at the time of Contract signing, agreement has not been reached between the Purchaser and the Supplier, an Adjudicator will be appointed by the Appointing Authority named in the SCC.

Appendix 5. Revised Price Schedules

The attached Revised Price Schedules (if any) shall form part of this Contract Agreement and, where differences exist, shall supersede the Price Schedules contained in the Supplier's Bid. These Revised Price Schedules reflect any corrections or adjustments to the Supplier's bid price, pursuant to the ITB Clauses 18.3, 26.2, and 33.1 (ITB Clauses 30.3, 38.2, and 45.1 in the two-stage SBD).

Appendix 6. Minutes of Contract Finalization Discussions and Agreed-to Contract Amendments

The attached Contract amendments (if any) shall form part of this Contract Agreement and, where differences exist, shall supersede the relevant clauses in the GCC, SCC, Technical Requirements, or other parts of this Contract as defined in GCC Clause 1.1 (a) (ii).

6. PERFORMANCE AND ADVANCE PAYMENT SECURITY FORMS

6.1 Performance Security Form (Bank Guarantee)

[insert: Bank's Name, and Address of Issuing Branch or Office]

Beneficiary: *[insert: Name and Address of Purchaser]*

Date: *[insert: date]*

PERFORMANCE GUARANTEE No.: *[insert: Performance Guarantee Number]*

We have been informed that on *[insert: date of award]* you awarded Contract No. *[insert: Contract number]* for *[insert: title and/or brief description of the Contract]* (hereinafter called "the Contract") to *[insert: complete name of Supplier]* (hereinafter called "the Supplier"). Furthermore, we understand that, according to the conditions of the Contract, a performance guarantee is required.

At the request of the Supplier, we hereby irrevocably undertake to pay you any sum(s) not exceeding *[insert: amount(s)¹ in figures and words]* upon receipt by us of your first demand in writing declaring the Supplier to be in default under the Contract, without cavil or argument, or your needing to prove or to show grounds or reasons for your demand or the sum specified therein.

On the date of your issuing, to the Supplier, the Operational Acceptance Certificate for the System, the value of this guarantee will be reduced to any sum(s) not exceeding *[insert: amount(s)¹ in figures and words]*. This remaining guarantee shall expire no later than *[insert: number and select: of months/of years (of the Warranty Period that needs to be covered by the remaining guarantee)]* from the date of the Operational Acceptance Certificate for the System,² and any demand for payment under it must be received by us at this office on or before that date.

This guarantee is subject to the Uniform Rules for Demand Guarantees, ICC Publication No. 458, except that subparagraph (ii) of Sub-article 20 (a) is hereby excluded.

[Signature(s)]

¹ The bank shall insert the amount(s) specified and denominated in the SCC for GCC Clauses 13.3.1 and 13.3.4 respectively, either in the currency(ies) of the Contract or a freely convertible currency acceptable to the Purchaser.

² In this sample form, the formulation of this paragraph reflects the usual SCC provisions for GCC Clause 13.3. However, if the SCC for GCC Clauses 13.3.1 and 13.3.4 varies from the usual provisions, the paragraph, and possibly the previous paragraph, need to be adjusted to precisely reflect the provisions specified in the SCC.

6.2 Advance Payment Security Form (Bank Guarantee)

[insert: Bank's Name, and Address of Issuing Branch or Office]

Beneficiary: *[insert: Name and Address of Purchaser]*

Date: *[insert: date]*

ADVANCE PAYMENT GUARANTEE No.: *[insert: Advance Payment Guarantee Number]*

We have been informed that on *[insert: date of award]* you awarded Contract No. *[insert: Contract number]* for *[insert: title and/or brief description of the Contract]* (hereinafter called "the Contract") to *[insert: complete name of Supplier]* (hereinafter called "the Supplier"). Furthermore, we understand that, according to the conditions of the Contract, an advance payment in the sum of *[insert: amount in numbers and words, for each currency of the advance payment]* is to be made to the Supplier against an advance payment guarantee.

At the request of the Supplier, we hereby irrevocably undertake to pay you any sum or sums not exceeding in total the amount of the advance payment referred to above, upon receipt by us of your first demand in writing declaring that the Supplier is in breach of its obligations under the Contract because the Supplier used the advance payment for purposes other than toward the proper execution of the Contract.

It is a condition for any claim and payment to be made under this guarantee that the advance payment referred to above must have been received by the Supplier on its account *[insert: number and domicile of the account]*.

For each payment after the advance payment, which you will make to the Supplier under this Contract, the maximum amount of this guarantee shall be reduced by the ninth part of such payment.¹ At the time at which the amount guaranteed becomes nil, this guarantee shall become null and void, whether the original is returned to us or not.

This guarantee is subject to the Uniform Rules for Demand Guarantees, ICC Publication No. 458.

[Signature(s)]

7. INSTALLATION AND ACCEPTANCE CERTIFICATES

7.1 Installation Certificate

Date: *[insert: date]*

Loan/Credit Number: *[insert: loan or credit number from IFB]*

IFB: *[insert: title and number of IFB]*

Contract: *[insert: name and number of Contract]*

To: *[insert: name and address of Supplier]*

Dear Sir or Madam:

Pursuant to GCC Clause 26 (Installation of the System) of the Contract entered into between yourselves and the *[insert: name of Purchaser]* (hereinafter the “Purchaser”) dated *[insert: date of Contract]*, relating to the *[insert: brief description of the Information System]*, we hereby notify you that the System (or a Subsystem or major component thereof) was deemed to have been correctly installed on the date specified below.

1. Description of the System (or relevant Subsystem or major component: *[insert: description]*)
2. Date of Installation: *[insert: date]*

Notwithstanding the above, you are required to complete the outstanding items listed in the attachment to this certificate as soon as practicable. This letter shall not relieve you of your obligation to achieve Operational Acceptance of the System in accordance with the Contract nor of your obligations during the Warranty Period.

For and on behalf of the Purchaser

Signed:

Date:

in the capacity of: *[state: “Project Manager” or state the title of a higher level authority in the Purchaser’s organization]*

7.2 Operational Acceptance Certificate

Date: *[insert: date]*

Loan/Credit Number: *[insert: loan or credit number from IFB]*

IFB: *[insert: title and number of IFB]*

Contract: *[insert: name of System or Subsystem and number of Contract]*

To: *[insert: name and address of Supplier]*

Dear Sir or Madam:

Pursuant to GCC Clause 27 (Commissioning and Operational Acceptance) of the Contract entered into between yourselves and the *[insert: name of Purchaser]* (hereinafter the "Purchaser") dated *[insert: date of Contract]*, relating to the *[insert: brief description of the Information System]*, we hereby notify you the System (or the Subsystem or major component identified below) successfully completed the Operational Acceptance Tests specified in the Contract. In accordance with the terms of the Contract, the Purchaser hereby takes over the System (or the Subsystem or major component identified below), together with the responsibility for care and custody and the risk of loss thereof on the date mentioned below.

1. Description of the System (or Subsystem or major component): *[insert: description]*
2. Date of Operational Acceptance: *[insert: date]*

This letter shall not relieve you of your remaining performance obligations under the Contract nor of your obligations during the Warranty Period.

For and on behalf of the Purchaser

Signed:

Date:

in the capacity of: *[state: "Project Manager" or higher level authority in the Purchaser's organization]*

8. CHANGE ORDER PROCEDURES AND FORMS

Date: *[insert: date]*

Loan/Credit Number: *[insert: loan or credit number from IFB]*

IFB: *[insert: title and number of IFB]*

Contract: *[insert: name or System or Subsystem and number of Contract]*

General

This section provides samples of procedures and forms for carrying out changes to the System during the performance of the Contract in accordance with GCC Clause 39 (Changes to the System) of the Contract.

Change Order Log

The Supplier shall keep an up-to-date Change Order Log to show the current status of Requests for Change and Change Orders authorized or pending. Changes shall be entered regularly in the Change Order Log to ensure that the log is kept up-to-date. The Supplier shall attach a copy of the current Change Order Log in the monthly progress report to be submitted to the Purchaser.

References to Changes

- (1) Request for Change Proposals (including Application for Change Proposals) shall be serially numbered CR-*nnn*.
- (2) Change Estimate Proposals shall be numbered CN-*nnn*.
- (3) Estimate Acceptances shall be numbered CA-*nnn*.
- (4) Change Proposals shall be numbered CP-*nnn*.
- (5) Change Orders shall be numbered CO-*nnn*.

On all forms, the numbering shall be determined by the original CR-*nnn*.

Annexes

- 8.1 Request for Change Proposal Form
- 8.2 Change Estimate Proposal Form
- 8.3 Estimate Acceptance Form
- 8.4 Change Proposal Form
- 8.5 Change Order Form
- 8.6 Application for Change Proposal Form

8.1 Request for Change Proposal Form

(Purchaser's Letterhead)

Date: *[insert: date]*

Loan/Credit Number: *[insert: loan or credit number from IFB]*

IFB: *[insert: title and number of IFB]*

Contract: *[insert: name of System or Subsystem or number of Contract]*

To: *[insert: name of Supplier and address]*

Attention: *[insert: name and title]*

Dear Sir or Madam:

With reference to the above-referenced Contract, you are requested to prepare and submit a Change Proposal for the Change noted below in accordance with the following instructions within *[insert: number]* days of the date of this letter.

1. Title of Change: *[insert: title]*
2. Request for Change No./Rev.: *[insert: number]*
3. Originator of Change: *[select Purchaser / Supplier (by Application for Change Proposal), and add: name of originator]*
4. Brief Description of Change: *[insert: description]*
5. System (or Subsystem or major component affected by requested Change): *[insert: description]*
6. Technical documents and/or drawings for the request of Change:

Document or Drawing No.	Description
-------------------------	-------------

7. Detailed conditions or special requirements of the requested Change: *[insert: description]*

8. Procedures to be followed:
 - (a) Your Change Proposal will have to show what effect the requested Change will have on the Contract Price.
 - (b) Your Change Proposal shall explain the time it will take to complete the requested Change and the impact, if any, it will have on the date when Operational Acceptance of the entire System agreed in the Contract.
 - (c) If you believe implementation of the requested Change will have a negative impact on the quality, operability, or integrity of the System, please provide a detailed explanation, including other approaches that might achieve the same impact as the requested Change.
 - (d) You should also indicate what impact the Change will have on the number and mix of staff needed by the Supplier to perform the Contract.
 - (e) You shall not proceed with the execution of work related to the requested Change until we have accepted and confirmed the impact it will have on the Contract Price and the Implementation Schedule in writing.

9. As next step, please respond using the Change Estimate Proposal form, indicating how much it will cost you to prepare a concrete Change Proposal that will describe the proposed approach for implementing the Change, all its elements, and will also address the points in paragraph 8 above pursuant to GCC Clause 39.2.1. Your Change Estimate Proposal should contain a first approximation of the proposed approach, and implications for schedule and cost, of the Change.

For and on behalf of the Purchaser

Signed:

Date:

in the capacity of: *[state: "Project Manager" or higher level authority in the Purchaser's organization]*

8.2 Change Estimate Proposal Form

(Supplier's Letterhead)

Date: *[insert: date]*

Loan/Credit Number: *[insert: loan or credit number from IFB]*

IFB: *[insert: title and number of IFB]*

Contract: *[insert: name of System or Subsystem and number of Contract]*

To: *[insert: name of Purchaser and address]*

Attention: *[insert: name and title]*

Dear Sir or Madam:

With reference to your Request for Change Proposal, we are pleased to notify you of the approximate cost of preparing the below-referenced Change in accordance with GCC Clause 39.2.1 of the Contract. We acknowledge that your agreement to the cost of preparing the Change Proposal, in accordance with GCC Clause 39.2.2, is required before we proceed to prepare the actual Change Proposal including a detailed estimate of the cost of implementing the Change itself.

1. Title of Change: *[insert: title]*
2. Request for Change No./Rev.: *[insert: number]*
3. Brief Description of Change (including proposed implementation approach): *[insert: description]*
4. Schedule Impact of Change (initial estimate): *[insert: description]*
5. Initial Cost Estimate for Implementing the Change: *[insert: initial cost estimate]*
6. Cost for Preparation of Change Proposal: *[insert: cost in the currencies of the Contract]*, as detailed below in the breakdown of prices, rates, and quantities.

For and on behalf of the Supplier

Signed:

Date:

in the capacity of: [state: ***“Supplier’s Representative” or other higher level authority in the Supplier’s organization***]

8.3 Estimate Acceptance Form

(Purchaser's Letterhead)

Date: *[insert: date]*

Loan/Credit Number: *[insert: loan or credit number from IFB]*

IFB: *[insert: title and number of IFB]*

Contract: *[insert: name of System or Subsystem and number of Contract]*

To: *[insert: name of Supplier and address]*

Attention: *[insert: name and title]*

Dear Sir or Madam:

We hereby accept your Change Estimate and agree that you should proceed with the preparation of a formal Change Proposal.

1. Title of Change: *[insert: title]*
2. Request for Change No./Rev.: *[insert: request number / revision]*
3. Change Estimate Proposal No./Rev.: *[insert: proposal number / revision]*
4. Estimate Acceptance No./Rev.: *[insert: estimate number / revision]*
5. Brief Description of Change: *[insert: description]*
6. Other Terms and Conditions:

In the event that we decide not to order the Change referenced above, you shall be entitled to compensation for the cost of preparing the Change Proposal up to the amount estimated

for this purpose in the Change Estimate Proposal, in accordance with GCC Clause 39 of the General Conditions of Contract.

For and on behalf of the Purchaser

Signed:

Date:

in the capacity of: [state: ***“Project Manager” or higher level authority in the Purchaser’s organization***]

8.4 Change Proposal Form

(Supplier's Letterhead)

Date: *[insert: date]*

Loan/Credit Number: *[insert: loan or credit number from IFB]*

IFB: *[insert: title and number of IFB]*

Contract: *[insert: name of System or Subsystem and number of Contract]*

To: *[insert: name of Purchaser and address]*

Attention: *[insert: name and title]*

Dear Sir or Madam:

In response to your Request for Change Proposal No. *[insert: number]*, we hereby submit our proposal as follows:

1. Title of Change: *[insert: name]*
2. Change Proposal No./Rev.: *[insert: proposal number/revision]*
3. Originator of Change: *[select: Purchaser / Supplier; and add: name]*
4. Brief Description of Change: *[insert: description]*
5. Reasons for Change: *[insert: reason]*
6. The System Subsystem, major component, or equipment that will be affected by the requested Change: *[insert: description]*
7. Technical documents and/or drawings for the requested Change:

- | Document or Drawing No. | Description |
|-------------------------|---|
| 8. | Estimate of the increase/decrease to the Contract Price resulting from the proposed Change: [<i>insert: amount in currencies of Contract</i>], as detailed below in the breakdown of prices, rates, and quantities.
Total lump sum cost of the Change:
Cost to prepare this Change Proposal (i.e., the amount payable if the Change is not accepted, limited as provided by GCC Clause 39.2.6): |
| 9. | Additional Time for Achieving Operational Acceptance required due to the Change: [<i>insert: amount in days / weeks</i>] |
| 10. | Effect on the Functional Guarantees: [<i>insert: description</i>] |
| 11. | Effect on the other terms and conditions of the Contract: [<i>insert: description</i>] |
| 12. | Validity of this Proposal: for a period of [<i>insert: number</i>] days after receipt of this Proposal by the Purchaser |
| 13. | Procedures to be followed:
(a) You are requested to notify us of your acceptance, comments, or rejection of this detailed Change Proposal within [<i>insert: number</i>] days from your receipt of this Proposal.
(b) The amount of any increase and/or decrease shall be taken into account in the adjustment of the Contract Price. |

For and on behalf of the Supplier

Signed:

Date:

in the capacity of: [state: "**Supplier's Representative**" or other higher level authority in the Supplier's organization]

8.5 Change Order Form

(Purchaser's Letterhead)

Date: *[insert: date]*

Loan/Credit Number: *[insert: loan or credit number from IFB]*

IFB: *[insert: title and number of IFB]*

Contract: *[insert: name of System or Subsystem and number of Contract]*

To: *[insert: name of Supplier and address]*

Attention: *[insert: name and title]*

Dear Sir or Madam:

We hereby approve the Change Order for the work specified in Change Proposal No. *[insert: number]*, and agree to adjust the Contract Price, Time for Completion, and/or other conditions of the Contract in accordance with GCC Clause 39 of the Contract.

1. Title of Change: *[insert: name]*
2. Request for Change No./Rev.: *[insert: request number / revision]*
3. Change Order No./Rev.: *[insert: order number / revision]*
4. Originator of Change: *[select: Purchaser / Supplier; and add: name]*
5. Authorized Price for the Change:

Ref. No.: *[insert: number]*

Date: *[insert: date]*

[insert: amount in foreign currency A] plus *[insert: amount in foreign currency B]* plus *[insert: amount in foreign currency C]* plus *[insert: amount in local currency]*

6. Adjustment of Time for Achieving Operational Acceptance: *[insert: amount and description of adjustment]*

7. Other effects, if any: *[state: “none” or insert description]*

For and on behalf of the Purchaser

Signed:

Date:

in the capacity of: *[state: “Project Manager” or higher level authority in the Purchaser’s organization]*

For and on behalf of the Supplier

Signed:

Date:

in the capacity of: *[state “Supplier’s Representative” or higher level authority in the Supplier’s organization]*

8.6 Application for Change Proposal Form

(Supplier's Letterhead)

Date: *[insert: date]*

Loan/Credit Number: *[insert: loan or credit number from IFB]*

IFB: *[insert: title and number of IFB]*

Contract: *[insert: name of System or Subsystem and number of Contract]*

To: *[insert: name of Purchaser and address]*

Attention: *[insert: name and title]*

Dear Sir or Madam:

We hereby propose that the below-mentioned work be treated as a Change to the System.

1. Title of Change: *[insert: name]*
2. Application for Change Proposal No./Rev.: *[insert: number / revision]* dated: *[insert: date]*
3. Brief Description of Change: *[insert: description]*
4. Reasons for Change: *[insert: description]*
5. Order of Magnitude Estimation: *[insert: amount in currencies of the Contract]*
6. Schedule Impact of Change: *[insert: description]*
7. Effect on Functional Guarantees, if any: *[insert: description]*

8. Appendix: *[insert: **titles** (if any); otherwise state “none”]*

For and on behalf of the Supplier

Signed:

Date:

in the capacity of: *[state: “**Supplier’s Representative**” or **higher level authority in the Supplier’s organization**]*